

TYPE	OUTPUT		POLE	TIME RATING	VOLTAGE	Hz	SYNSPEED R.P.M
	HP.	KW.					
AEHH8N	125	93.3	6	CONT.	190/380	50	1000

TOTALLY ENCLOSED FAN-COOLED TYPE, SQUIRREL-CAGE ROTOR

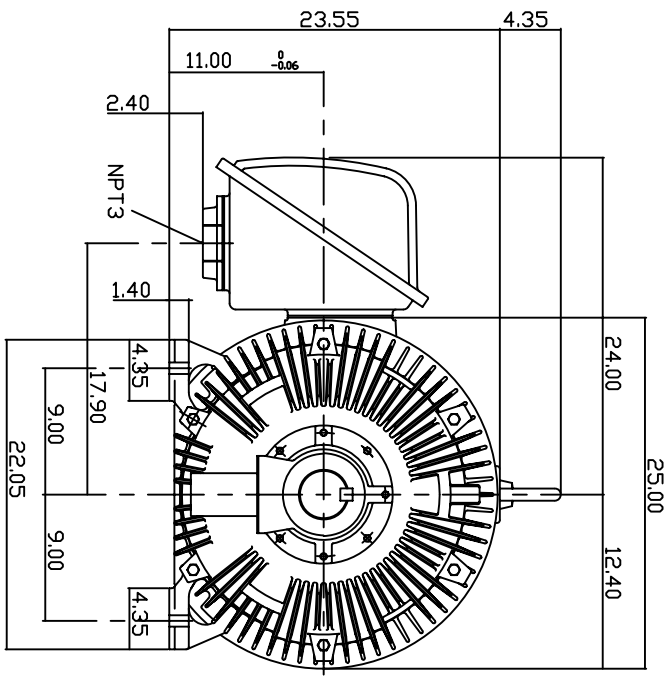
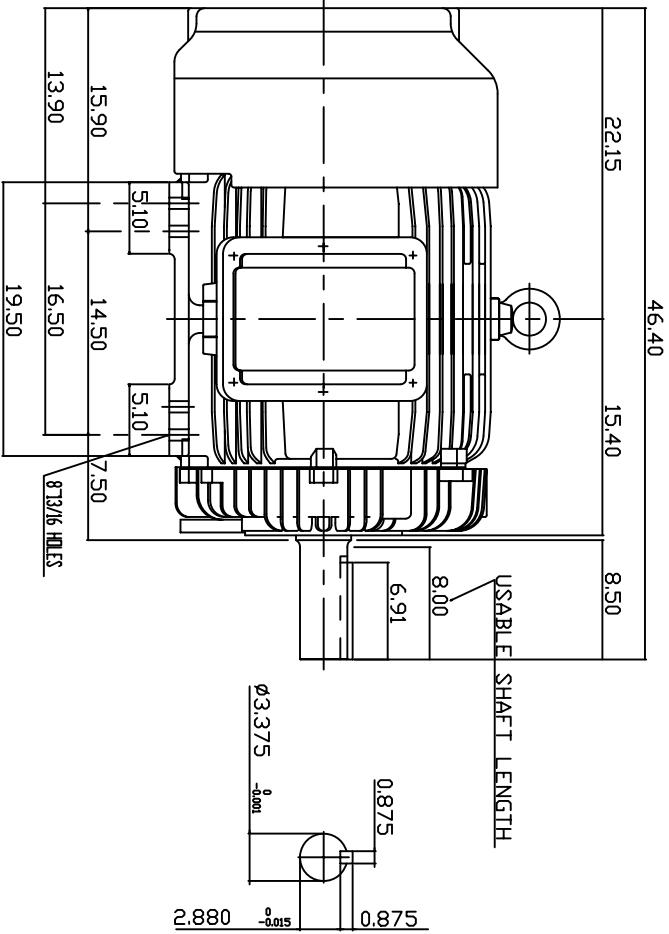

NOTE:

1. DIMENSIONS IN INCH
2. FRAME NO. 445T
3. F CLASS INSULATION, S.F.115
4. FOR DIRECT FLEXIBLE COUPLING
5. ENCLOSURE: IP54
6. BEARING SIZE: DRIVE END: 6318
NON-DRIVE END: 6316
7. APPROX. WEIGHT: 1900 LBS

TW-56C

DWN.	S.DING	JAN -28 -2005
CHKD.	H.HUANG	JAN -28 -2005
APPD.	C.WANG	JAN -28 -2005

DATE 20050616
 CAT. # EP1256-50
 3-PHASE INDUCTION MOTOR
 Dwg NO. 3A040Y651
 REV: 00