

DATE
Sept. 25, 2006
Cat. #: EP0754C-50

OUTLINE DIMENSIONS
3-PHASE INDUCTION MOTOR

MOTOR TYPE:
AEHH8N-CF
FRAME NO. 365TC

Pole	HP	kW	Hz	VOLT	Syn. Speed r/min(rpm)
4	75	56	50	190/380	1500

Ins	Rating	Dimension in	Approx Weight	Bearings	
F	CONT.	inches	951 lbs	DE: 6313	NDE: 6213

Totally Enclosed Fan Cooled Type. Squirrel-cage Rotor.

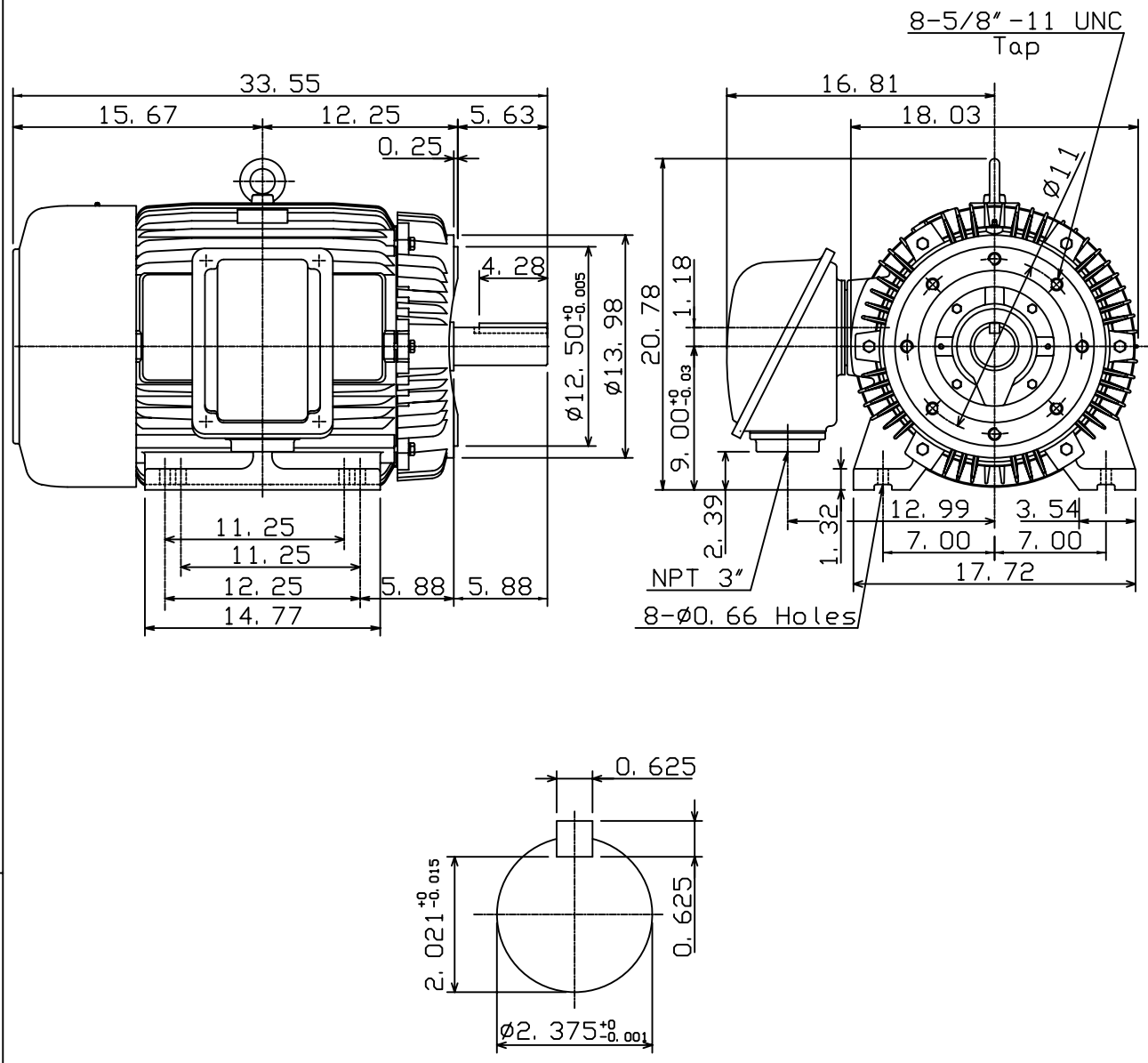

\diamond		
------------	--	--

DWN.	K. L. KUO	01-11-05
CHKD.	C. H. KAO	01-28-05
APPD.	M. C. TSAI	01-28-05



DWG NO.
31049J715200