

DATE
JUNE 21, 2005
CATALOG NO.
EP0602

OUTLINE DIMENSIONS
3-PHASE INDUCTION MOTOR

MOTOR TYPE:
AEHH8N
FRAME NO. 364TS

Pole	HP	KW	Hz	VOLT	Syn. Speed RPM
2	60	45	60	230/460	3600

Ins	Rating	Dimension in	Approx Weight	Bearings
F	CONT.	inches	818 lbs.	DE: 6312C3 NDE: 6212C3

Totally Enclosed Fan-Cooled Type. Squirrel-Cage Rotor.

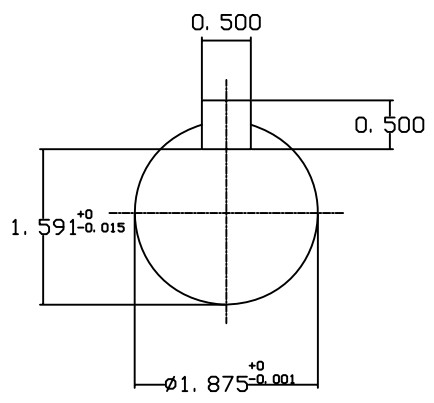
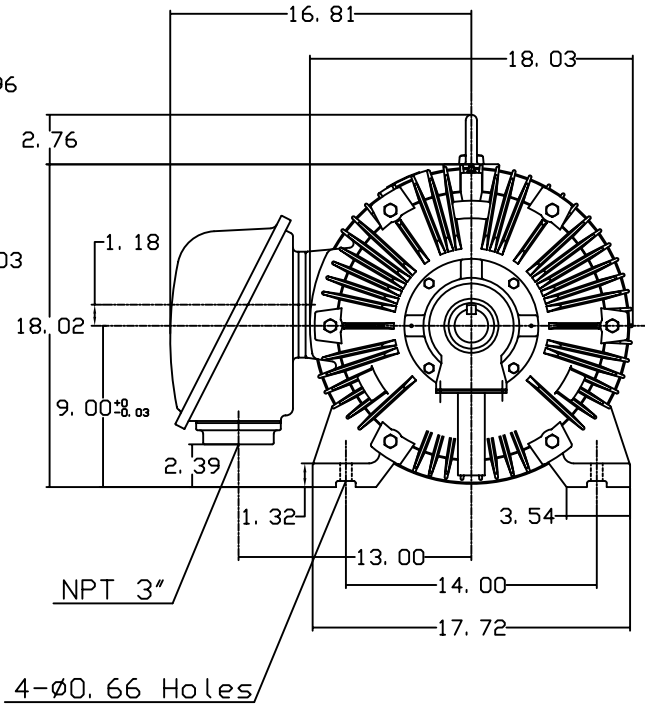
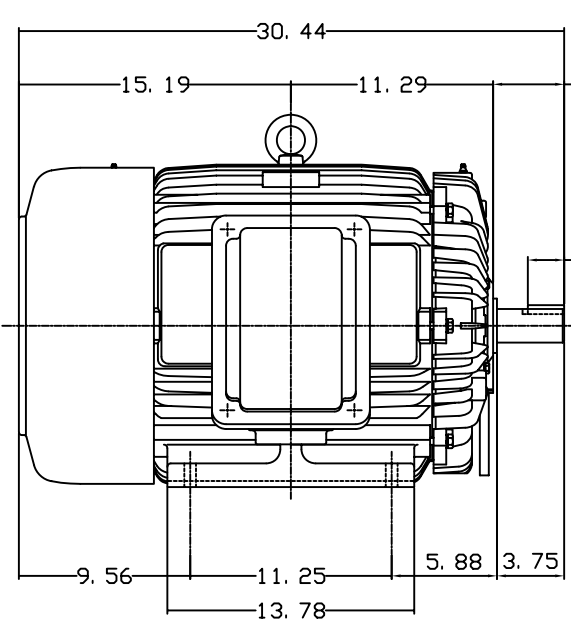

DWN.	J. H. LIANG	11-30-98
CHKD.	C. H. KAO	12-26-98
APP'D.	Y. B. HUANG	12-26-98



DWG NO.
31057H367000