

DATE
Feb. 16, 2007
CATALOG NO.
EP0404S-50

OUTLINE DIMENSIONS
3-PHASE INDUCTION MOTOR

MOTOR TYPE:
AEHH8N
FRAME NO. 324TS

Pole	HP	KW	Hz	VOLT	Syn. Speed RPM
4	40	29.84	50	190/380	1500

Ins	Rating	Dimension in	Approx Weight	Bearings	
F	CONT.	inches	650 lbs.	DE: 6312	NDE: 6212

Totally Enclosed Fan-Cooled Type. Squirrel-Cage Rotor.

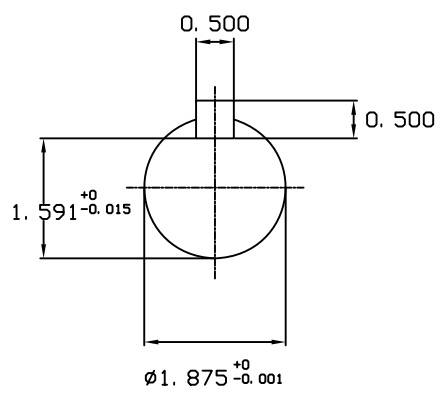
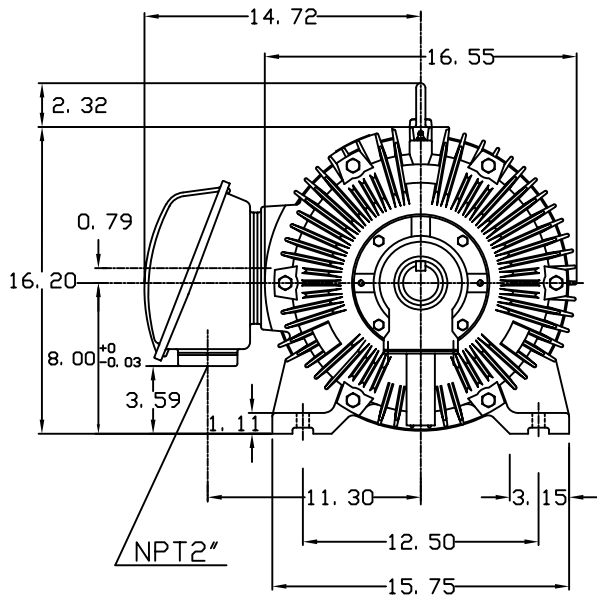
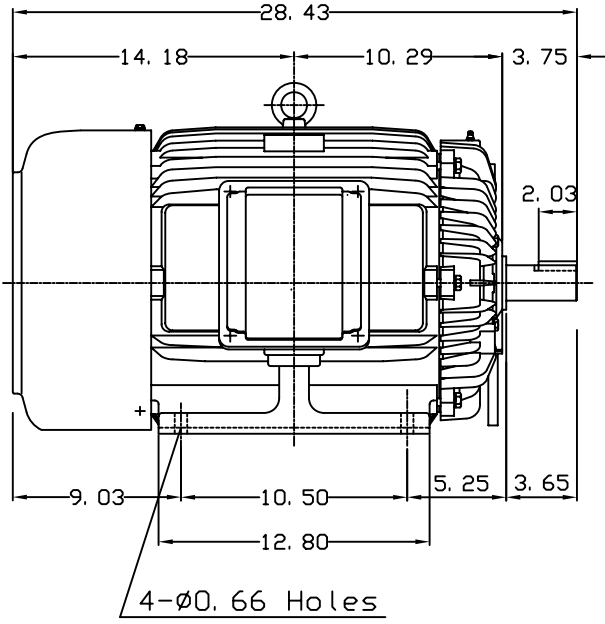

① 03.16.00 J. C. LIN

DWN. J. H. LIANG 11-30-98
CHKD. C. H. KAO 12-26-98
APPD. Y. B. HUANG 12-26-98



DWG NO.
31057H365001A