

TYPE	OUTPUT		POLE	TIME RATING	VOLTAGE V	Hz	SYN SPEED R.P.M
	HP.	KW.					
AEHE	800	597	6	CDNT.	380	50	1000

TOTALLY ENCLOSED FAN-COOLED TYPE, SQUIRREL-CAGE ROTOR

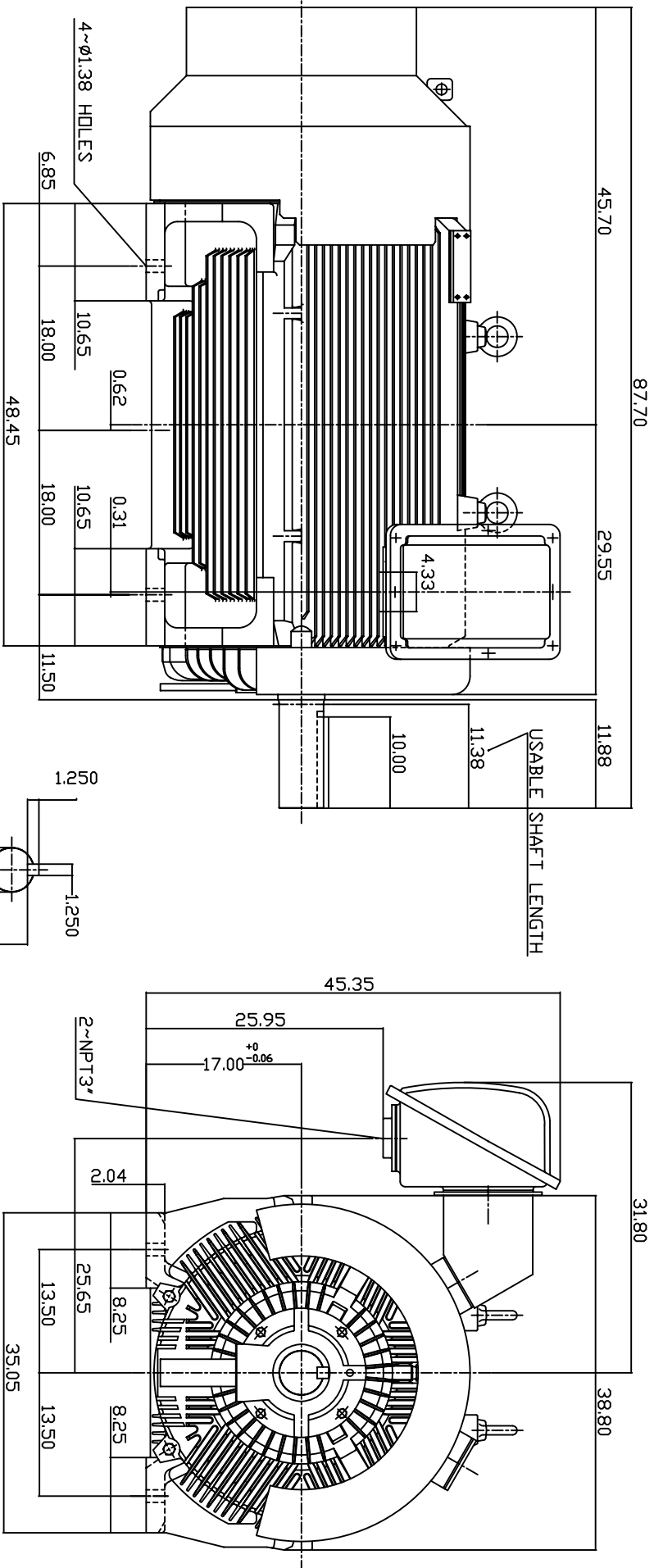

- NOTE:
1. DIMENSIONS IN INCH.
 2. FRAME NO. 6808C
 3. F CLASS INSULATION, S.F.1.0
 4. FOR BELT DRIVE APPLICATIONS
 5. BEARING SIZE: DRIVE END: NU326C3
NON-DRIVE END: 6322
 6. MOTOR APPROX. WEIGHT: 8000 LBS

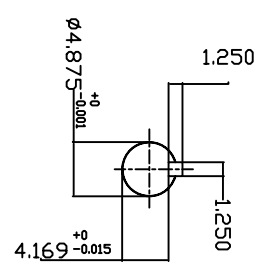

DVN.	W.LLIN	MAR-04-2003
CHKD.	W.LLIN	MAR-04-2003
APPD.	C.WANG	MAR-04-2003

DATE	APRIL 26, 2004	OUTLINE DIMENSIONS
CATALOG NO.	E8006R-50	
3-PHASE INDUCTION MOTOR		DWG NO. 3A040T187-3
TECO Westinghouse		REV: 00

TW-66C