

TYPE	OUTPUT		POLE	TIME RATING	VOLTAGE V	Hz	SYN SPEED R.P.M
	HP.	KW.					
AEHE	600	448	8	CDNT.	380	50	750

TOTALLY ENCLOSED FAN-COOLED TYPE. SQUIRREL-CAGE ROTOR

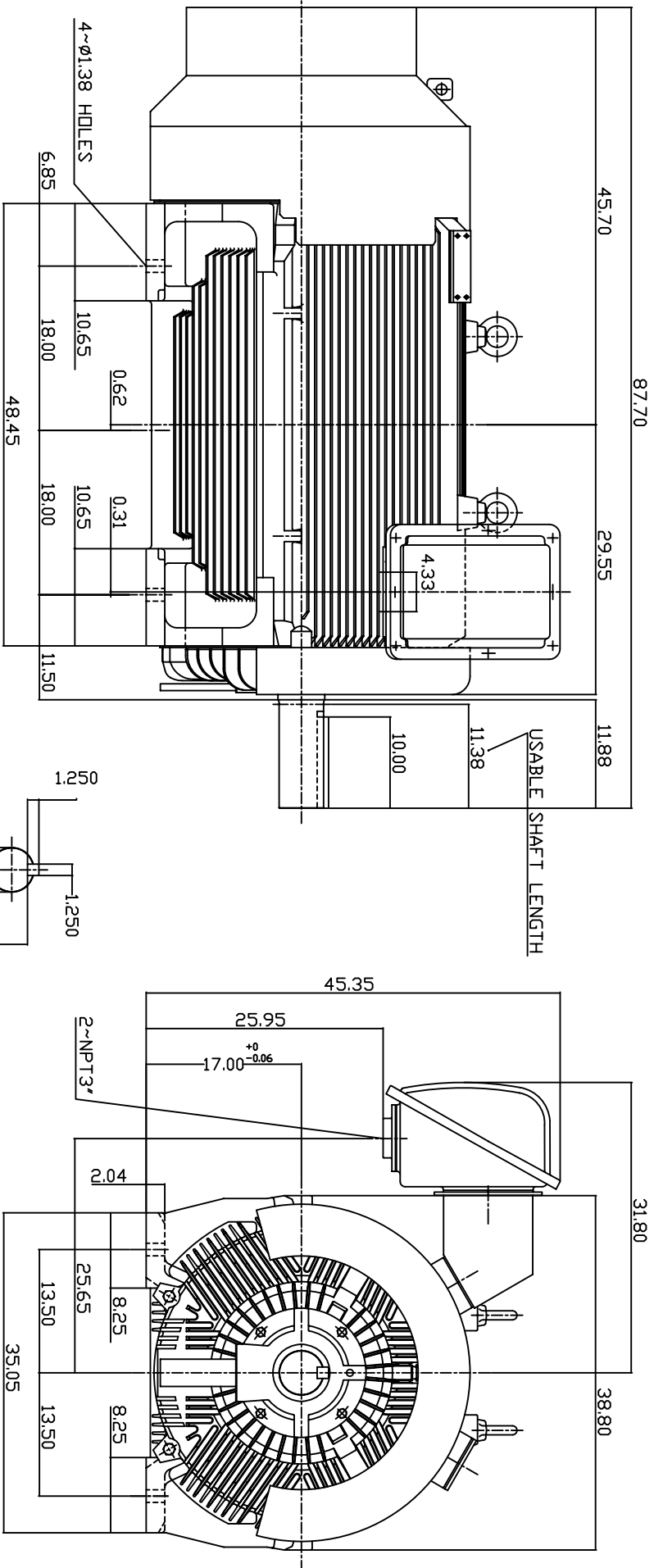

NOTE:

1. DIMENSIONS IN INCH.
2. FRAME NO. 6808C
3. F CLASS INSULATION, S.F.1.0
4. FOR BELT DRIVE APPLICATIONS
5. BEARING SIZE: DRIVE END: NU326C3
NON-DRIVE END: 6322
6. MOTOR APPROX. WEIGHT: 8050 LBS

TW-66C

DVN.	W.LLIN	MAR-04-2003
CHKD.	W.LLIN	MAR-04-2003
APPD.	C.WANG	MAR-04-2003

DATE	APRIL 26, 2004	OUTLINE DIMENSIONS
CATALOG NO.	E6008R-50	
3-PHASE INDUCTION MOTOR		DWG NO.
TECO Westinghouse		3A040T187
		REV: 00