

DATE  
MAY 28, 2009  
CATALOG # DTP0206G

OUTLINE DIMENSIONS  
3-PHASE INDUCTION MOTOR

MOTOR TYPE:  
ASGH-SGR  
FRAME NO. 286T

Pole	HP	kW	Hz	VOLT	Syn.Speed r/min(rpm)
6	20	14.9	60	230/460	1200
Ins	Rating	Dimension in	Approx Weight	Bearings	
F	CONT.	inches	364 lbs.	DE: 6311ZZC3 NDE: 6211ZZC3	

Open Protected Drip-Proof Type.Squirrel-cage Rotor.

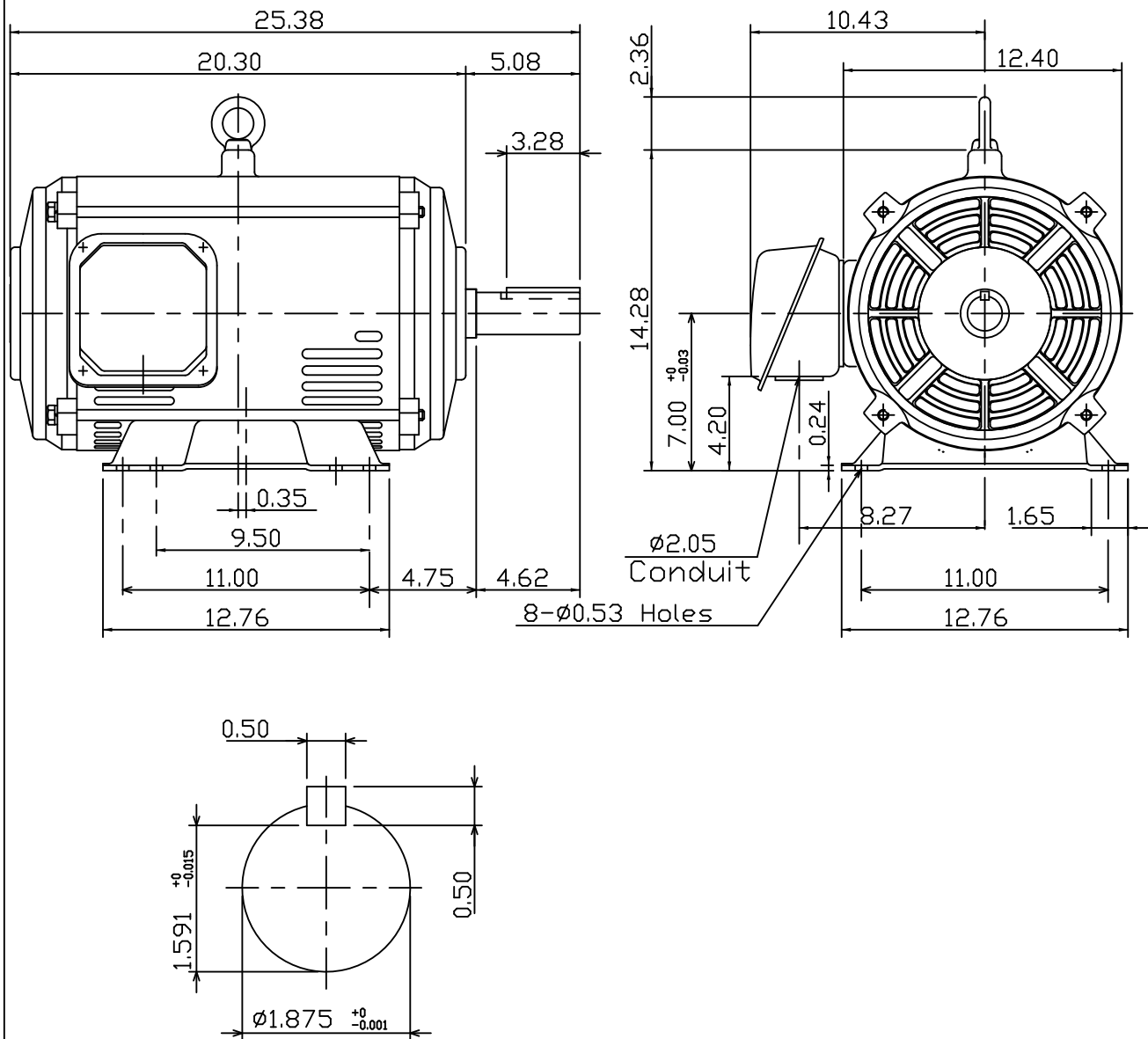

NOTE:  
1.AEGIS Grounding ring installed on Drive-end.



DWN.	K.L.KUD	04-28-08
CHKD.	K.L.KUD	05-05-08
APPD.	M.C.TSAI	05-05-08



DWG NO.  
31057H724060