

DATE  
MAY 28, 2009  
CATALOG # DTP0154G

OUTLINE DIMENSIONS  
3-PHASE INDUCTION MOTOR

MOTOR TYPE:  
ASGH-SGR  
FRAME NO. 254T

Pole	HP	kW	Hz	VOLT	Syn.Speed r/min(rpm)
4	15	11.2	60	230/460	1800
Ins	Rating	Dimension in	Approx Weight	Bearings	
F	CONT.	inches	230 lbs.	DE: 6309ZZC3NDE: 6208ZZC3	

Open Protected Drip-Proof Squirrel-Cage Rotor.

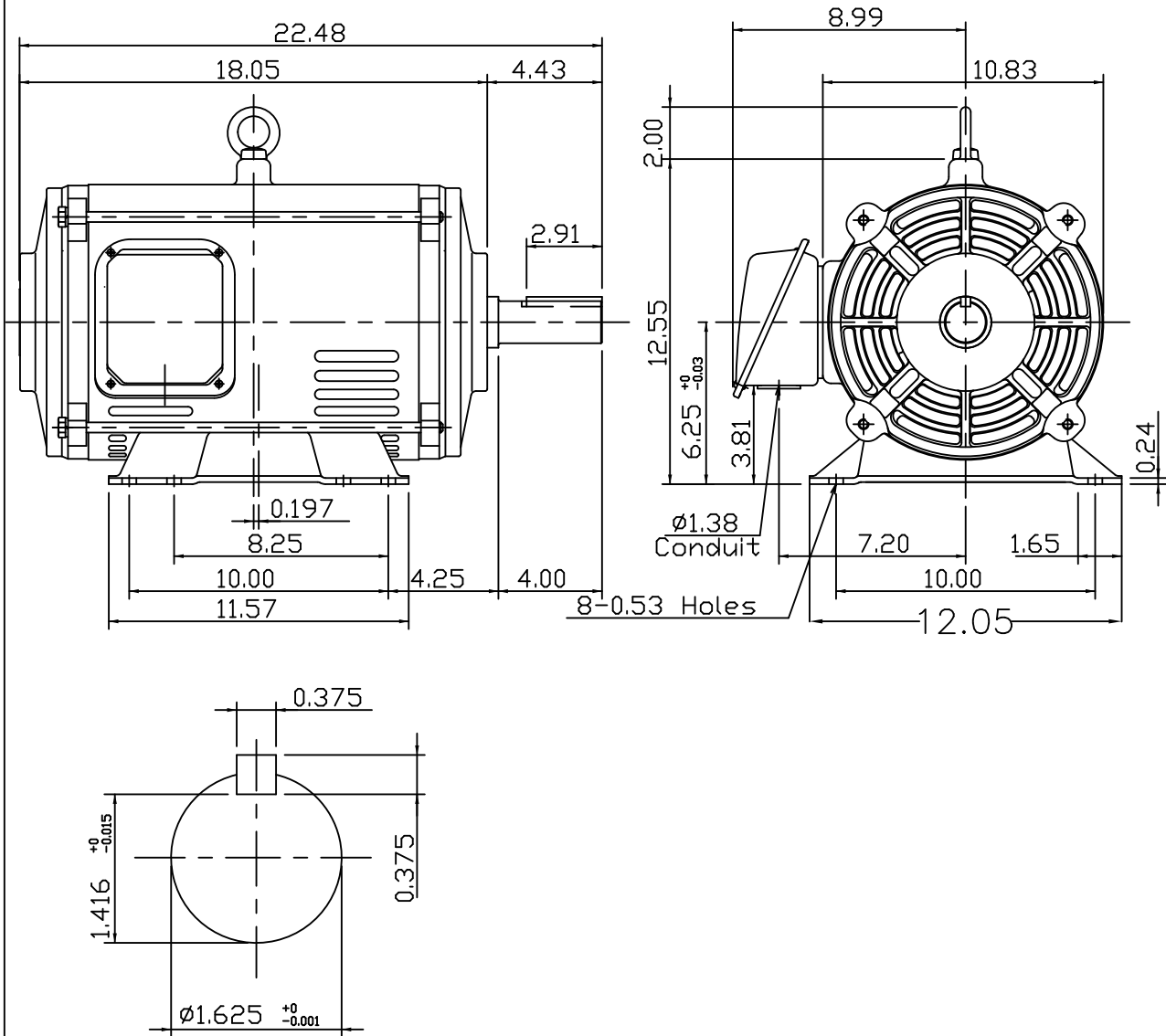

NOTE:  
1.AEGIS Grounding ring installed on Drive-end.



DWN.	K.L.KUD	05-11-08
CHKD.	K.L.KUD	05-11-08
APPD.	M.C.TSAI	05-11-08

TECO Westinghouse

DWG NO.  
31057H739140