

DATE
February 16, 2004

OUTLINE DIMENSIONS
3-PHASE INDUCTION MOTOR

MODEL TYPE:
ASGA

FRAME NO. B56

CATALOG NO.
DS0024

Pole	HP	KW	Hz	VOLT	Syn. Speed R. P. M
4	2	1.5	60	230/460	1800

Ins.	Rating	Dimensions in	Approx Weight	Bearings
F	CONT.	inch	33.44 lbs	DF: 6205ZZ NDE: 6204ZZ

OPEN DRIP-PROOF

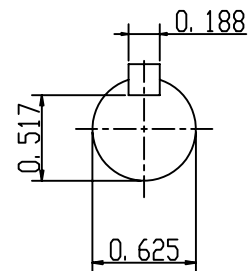
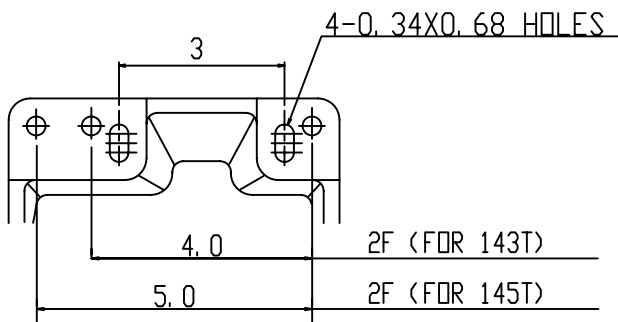
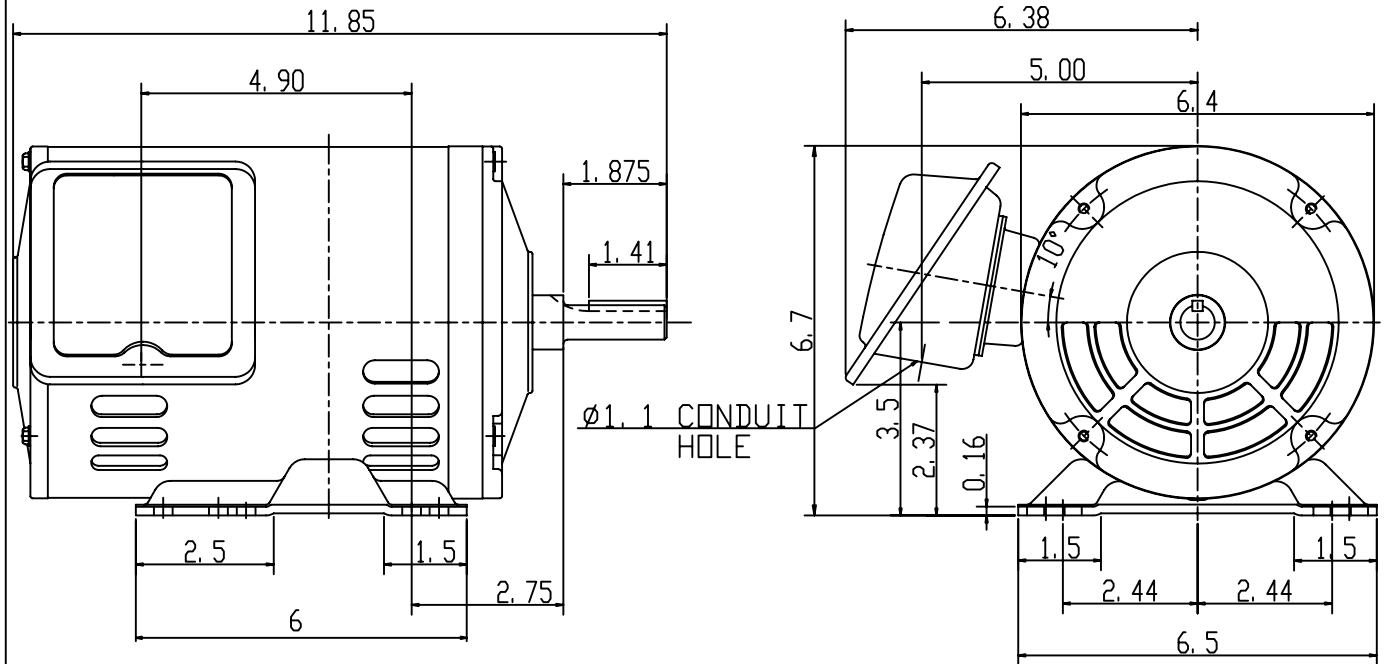

SCALE=3: 1

APPD.	W. H. TSAI	04 03 03
CHKD.	J. B. CHEN	04 03 03
DWN.	P. J. CHEN	04 03 03

TECO Westinghouse

DWG NO.
31049Z105
0873