

DATE FEBRUARY 23, 2007	OUTLINE DIMENSIONS 3-PHASE INDUCTION MOTOR	MOTOR TYPE: ASHH
CATALOG NO. DHP7/56G		FRAME NO. 254T

Pole	HP	KW	Hz	VOLT	Syn. Speed RPM
6	7.5	5.6	60	230/460	1200

Ins	Rating	Dimension in	Approx Weight	Bearings	
F	CONT.	inch	247 lbs.	DE: 6310zz	NDE: 6309zz

Open Protected Drip-Proof Squirrel-Cage Rotor.

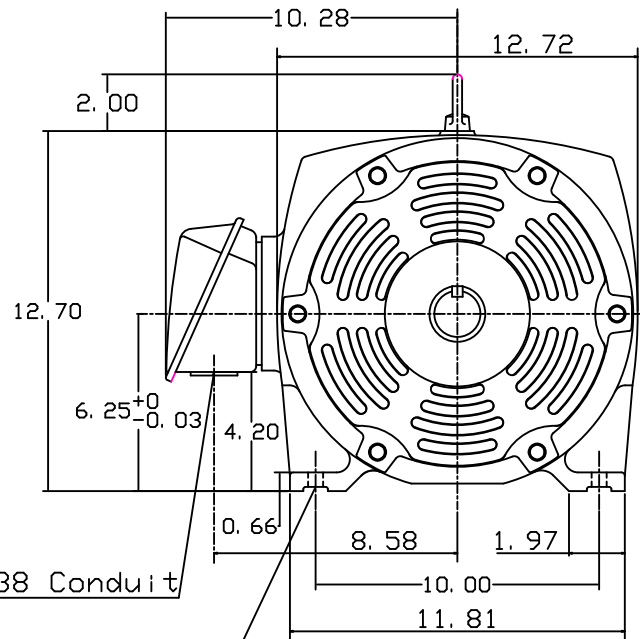
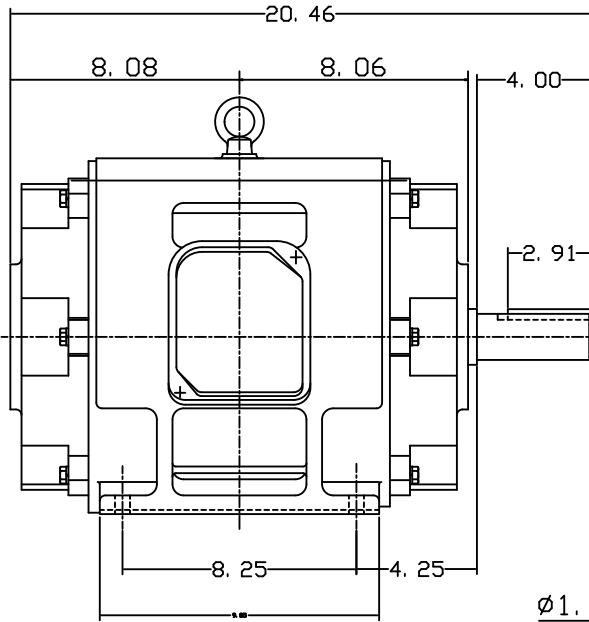

Ø1.38 Conduit

4-0.53 Holes

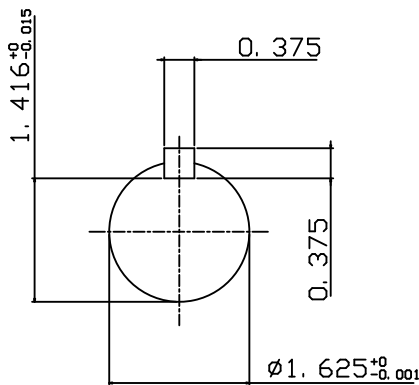

NOTE:
1. AEGIS Grounding ring installed on Drive-end.



DWN.	J. H. LIANG	12-22-98
CHKD.	C. H. KAO	06-10-99
APPD.	Y. B. HUANG	06-10-99

TECO Westinghouse

DWG NO.
31057H383000