

TYPE	OUTPUT		POLE	TIME RATING CDNT.	VOLTAGE V	Hz	SYN.SPEED R.P.M
	HP.	K.W.					
ASHH	400	298	2		380	50	3000

DRIP PROOF TYPE, SQUIRREL-CAGE ROTOR

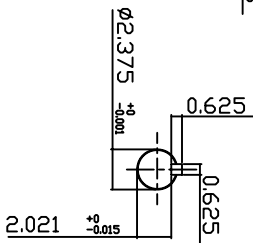

USABLE SHAFT LENGTH

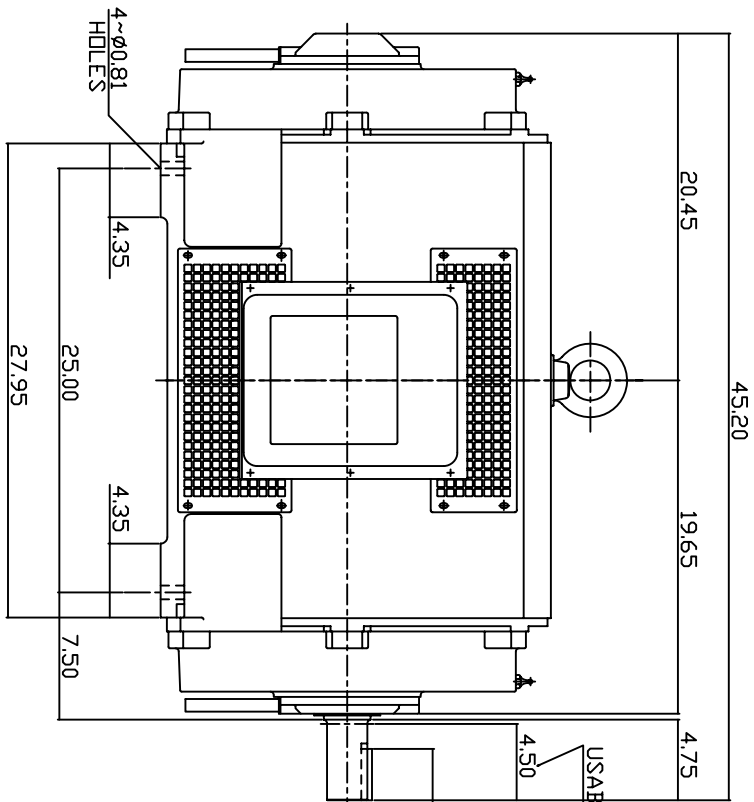
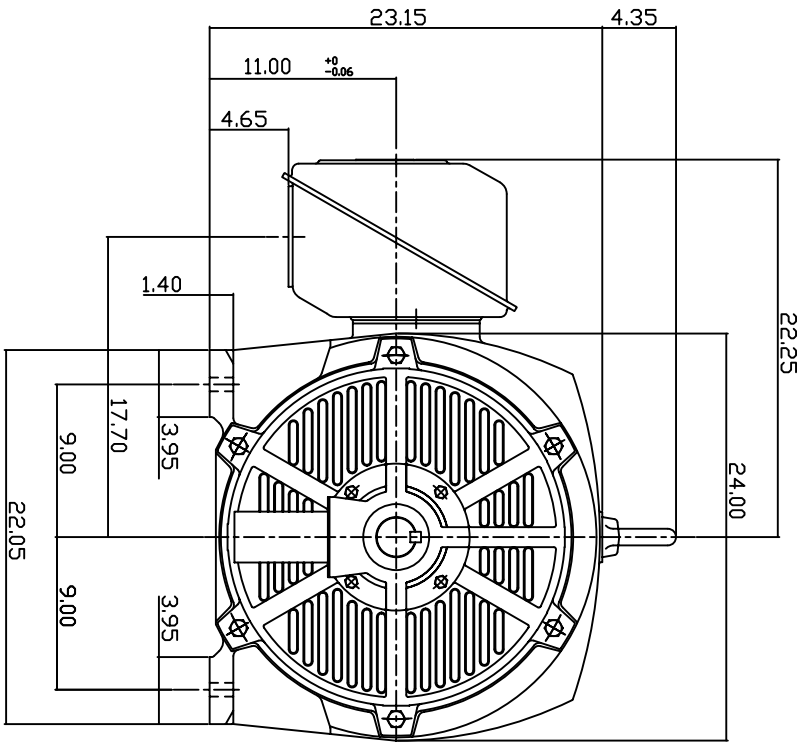

NOTE:

1. DIMENSIONS IN INCH.
2. FRAME NO. 449TS
3. F CLASS INSULATION, S.F. 1.0
4. FOR DIRECT FLEXIBLE COUPLING
5. BEARING SIZE: DRIVE END: 6315C3
NON-DRIVE END: 6315C3
6. MOTOR APPROX. WEIGHT: 1760 LBS

TB-56SC

D/W.N.	V.L.LIN	MAR. 26. 2003
CHKD.	V.L.LIN	MAR. 26. 2003
APPD.	C.WANG	MAR. 26. 2003

DATE	February 24, 2007	OUTLINE DIMENSIONS
CATALOG NO.	DH14002-50	3-PHASE INDUCTION MOTOR



DWG NO. 3A040T264 REV: 00