

TYPE	OUTPUT		POLE	TIME RATING	VOLTAGE	Hz	SYN.SPEED R.P.M
	HP.	KW.					
ASHH	250	186.5	4	CDNT.	460	60	1800

DRIP PROOF TYPE, SQUIRREL-CAGE ROTOR

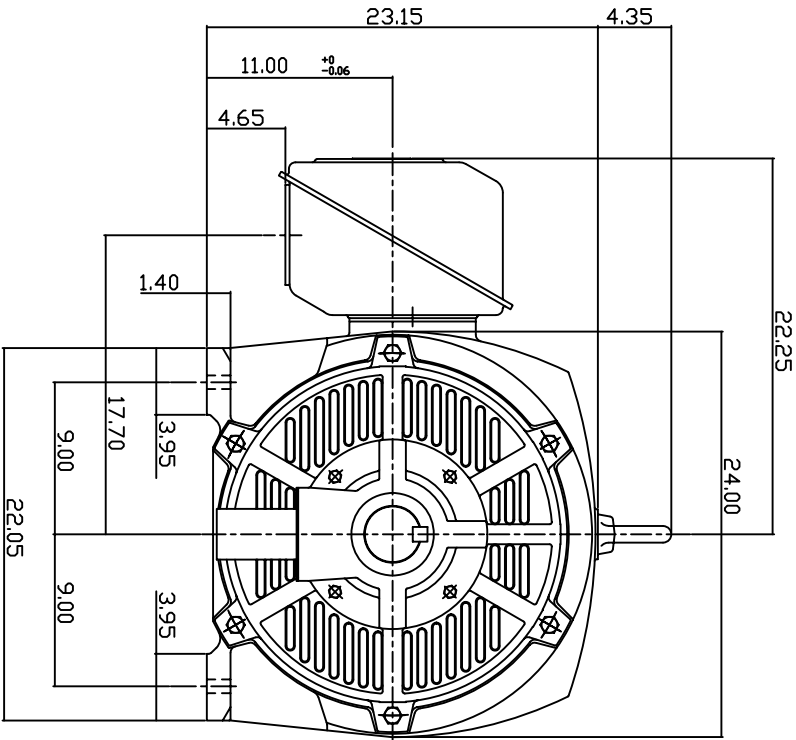
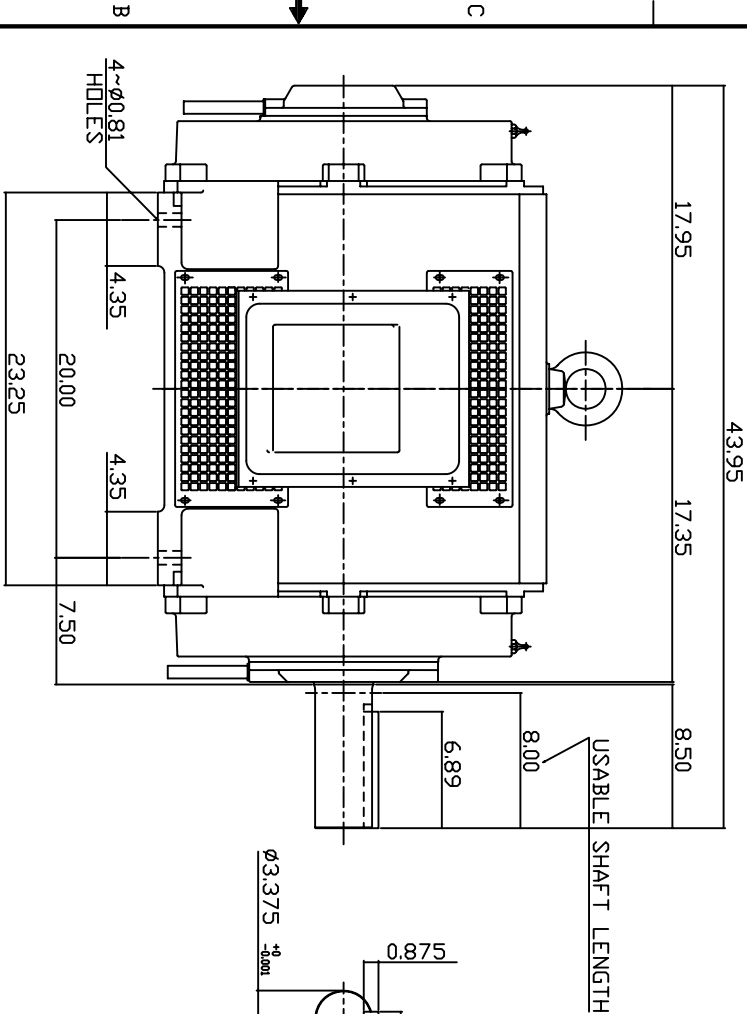

NOTE:
1. DIMENSIONS IN INCH.
2. FRAME NO. 447T
3. F CLASS INSULATION, S.F.1.15
4. FOR BELT DRIVE APPLICATIONS
5. BEARING SIZE: DRIVE END: NU320
NON-DRIVE END: 6318
6. MOTOR APPROX. WEIGHT: 1810 LBS

1. DIMENSIONS IN INCH.
2. FRAME NO. 447T
3. F CLASS INSULATION, S.F.1.15
4. FOR BELT DRIVE APPLICATIONS
5. BEARING SIZE: DRIVE END: NU320
NON-DRIVE END: 6318
6. MOTOR APPROX. WEIGHT: 1810 LBS

TB-56SC

DWN.	W.LLIN	MAR-26-2003
CHKD.	W.LLIN	MAR-26-2003
APPD.	C.WANG	MAR-26-2003

DATE	February 24, 2007	OUTLINE DIMENSIONS
CATALOG NO.	DHP2504R	
3-PHASE INDUCTION MOTOR		DWG NO.
TECO Westinghouse		3A040T263-1
		REV. 00