

DATE  
February 24, 2007  
CATALOG NO.  
DHP0504G

OUTLINE DIMENSIONS  
3-PHASE INDUCTION MOTOR

MOTOR TYPE:  
ASHH  
FRAME NO. 326T

Pole	HP	KW	Hz	VOLT	Syn. Speed RPM
4	50	37.3	60	230/460	1800

Ins	Rating	Dimension in	Approx Weight	Bearings
F	CONT.	inch	595 lbs.	DE: 6213 NDE: 6213

Open Protected Drip-Proof Squirrel-Cage Rotor.

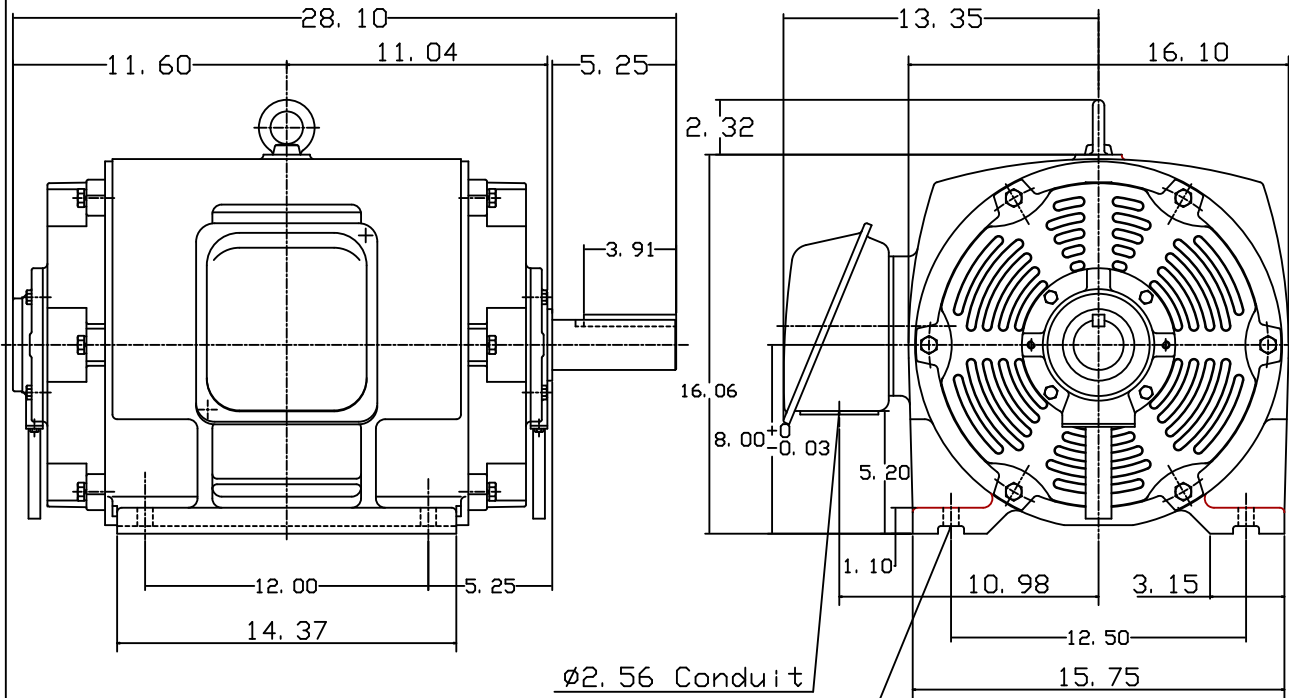

ø2.56 Conduit

4-ø0.66 Holes

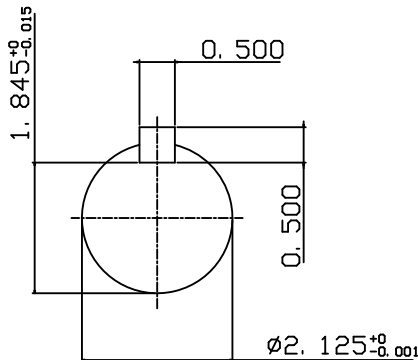

NOTE: 1. AEGIS Grounding ring installed inside bracket on Non-Drive-end.



DWN.	J. H. LIANG	12-22-98
CHKD.	C. H. KAO	06-10-99
APPD.	Y. B. HUANG	06-10-99



DWG NO.  
31057H392001