

DATE February 24, 2007	OUTLINE DIMENSIONS 3-PHASE INDUCTION MOTOR	MOTOR TYPE: ASHH
CATALOG NO. DHP0404G		FRAME NO. 324T

Pole	HP	KW	Hz	VOLT	Syn. Speed RPM
4	40	30	60	230/460	1800

Ins	Rating	Dimension in	Approx Weight	Bearings	
F	CONT.	inch	520 lbs.	DE: 6213	NDE: 6213

Open Protected Drip-Proof Squirrel-Cage Rotor.

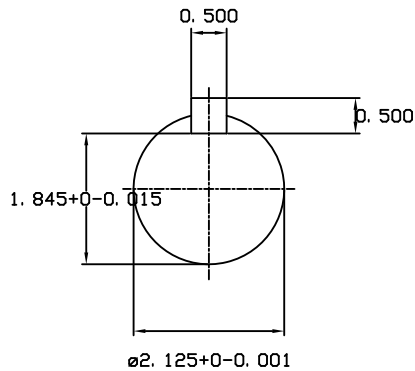
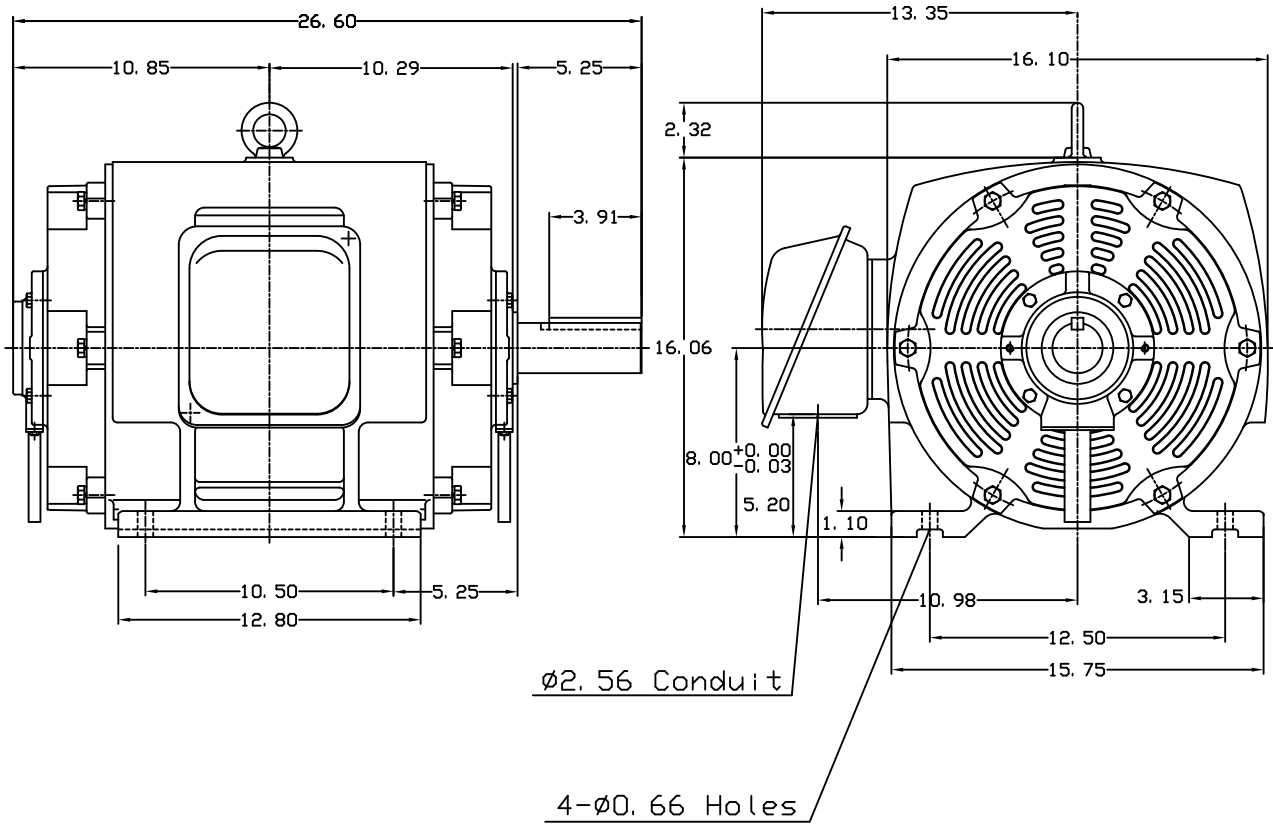

NOTE: 1. AEGIS Grounding ring installed inside bracket on Non-Drive-end.

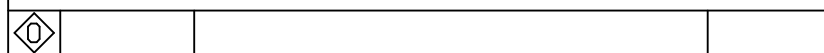

DWN. J. H. LIANG 12-22-98	TECO  Westinghouse 	DWG NO.
CHKD. C. H. KAO 06-10-99		31057H390001
APPD. Y. B. HUANG 06-10-99		