

DATE
FEBRUARY 23, 2007
CATALOG NO.
DHP0302G

OUTLINE DIMENSIONS
3-PHASE INDUCTION MOTOR

MOTOR TYPE:
ASHH
FRAME NO. 284TS

Pole	HP	KW	Hz	VOLT	Syn. Speed RPM
2	30	22.4	60	230/460	3600

Ins	Rating	Dimension in	Approx Weight	Bearings
F	CONT.	inch	370 lbs.	DE: 6212C3 NDE: 6211C3

Open Protected Drip-Proof Type. Squirrel-cage Rotor.

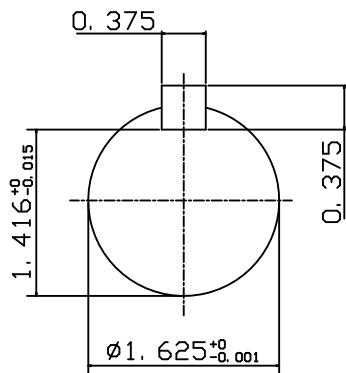
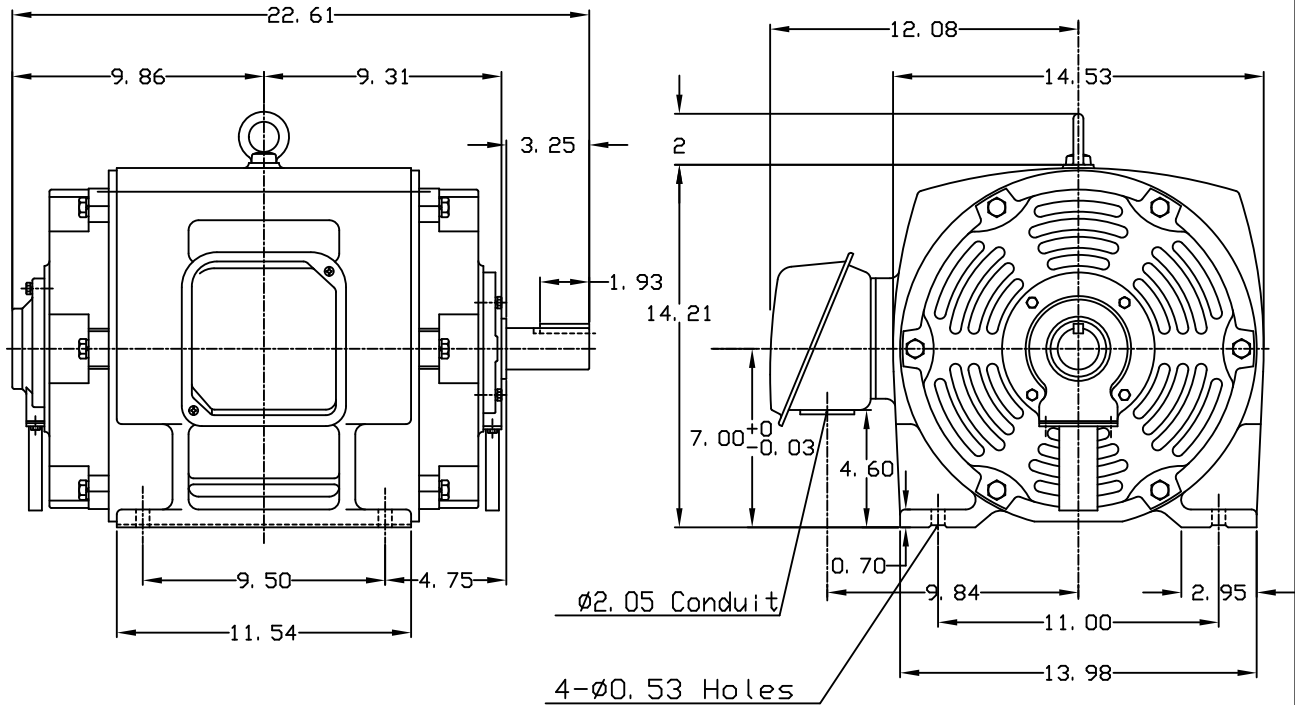

NOTE:
1. AEGIS Grounding ring installed on Drive-end.

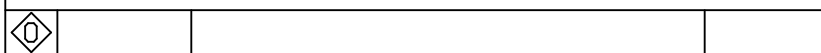

DWN.	J. H. LIANG	12-22-98
CHKD.	C. H. KAO	06-10-99
APPD.	Y. B. HUANG	06-10-99

TECO Westinghouse

DWG NO.
31057H385000