

TYPE	OUTPUT	POLE	RATING	VOLTAGE	Hz	SYNSPEED R.P.M
	HP.					
AECA	125 / 31	4 / 8	CDNT.	460	60	1800/900

TOTALLY ENCLOSED FAN-COOLED TYPE, SQUIRREL-CAGE ROTOR
2 SPEED, 1 WINDING VARIABLE TORQUE

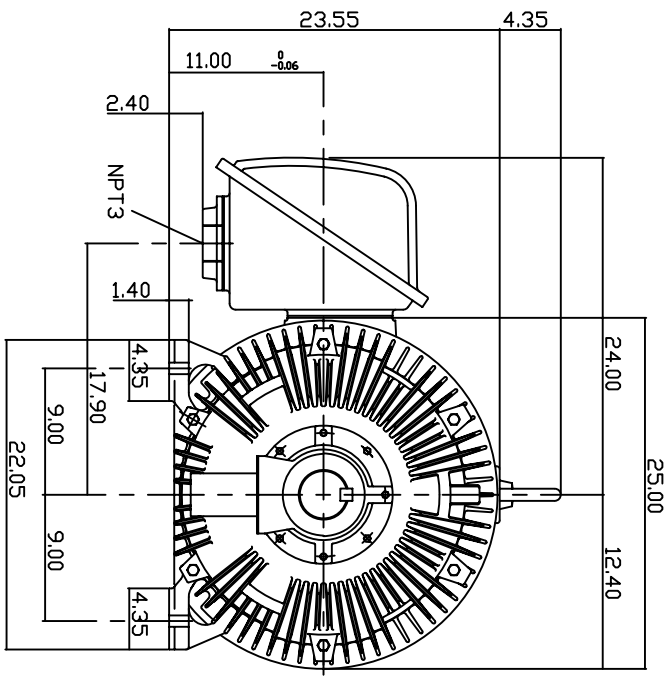
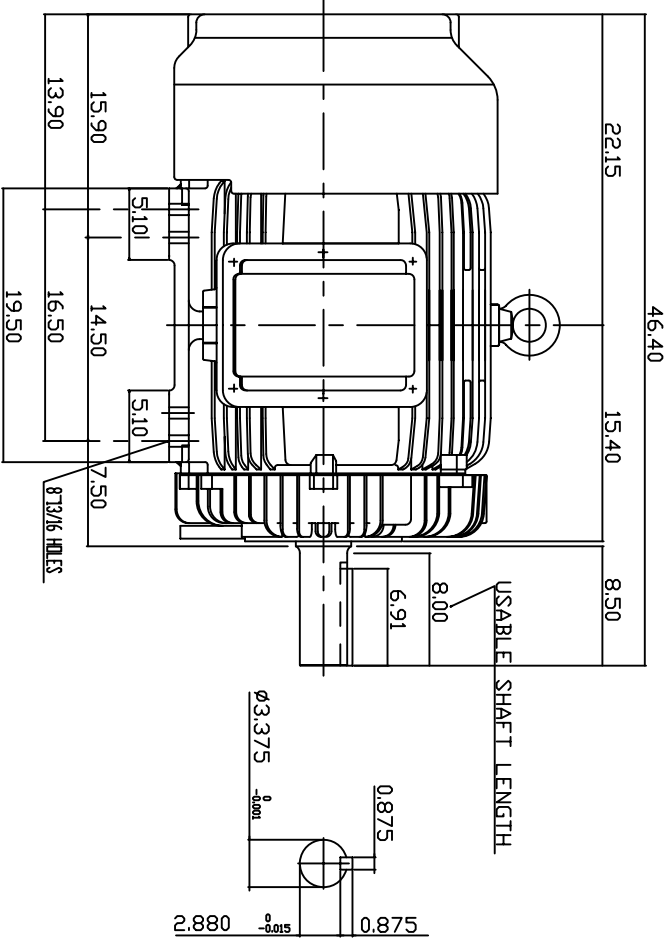

- NOTE:
1. DIMENSIONS IN INCH
 2. FRAME NO. 445T
 3. F CLASS INSULATION, S.F.115
 4. FOR DIRECT FLEXIBLE COUPLING
 5. ENCLOSURE: IP55
 6. BEARING SIZE: DRIVE END: 6318
NON-DRIVE END: 6316
 7. APPROX. WEIGHT: 1900 LBS

TW-56C

DWN.	S.DING	JAN -28 -2005
CHKD.	H.HUANG	JAN -28 -2005
APPD.	C.WANG	JAN -28 -2005

Nov. 15, 2007

CAT. # CP1254/8

3-PHASE INDUCTION MOTOR

TECO Westinghouse

DWG NO. 3A040Y651-1

REV: 00