

## Data sheet for three-phase Squirrel-Cage-Motors

Totally Enclosed Fan Cooled (TEFC)



MLFB-Ordering data: **1LE2421-4CD31-2AA3**

Motor type: **SD100 IEEE841 - NEMA Premium Efficiency**

Client order no.:

Order no.:

Offer no.:

Remarks:

Item no.:

Consignment no.:

Project:

U [V]	$\Delta / Y$	f [Hz]	P [HP]	P [kW]	n [rpm]	I Load [Amps]					LRC	Nom. Eff Load [%]			Pwr. Factor Load [%]			Torque [lb-ft]	T <sub>A</sub> /T <sub>N</sub> LRT [%]	T <sub>k</sub> /T <sub>N</sub> BDT [%]
						4/4	3/4	1/2	0	4/4		3/4	1/2	4/4	3/4	1/2				
460	$\Delta$	60	125.00	90.00	885	152.00	117.30	88.40	54.00	908.0	94.1	94.7	94.6	82.0	79.0	70.0	742.0	130	200	

Frame Type 447T	Type of constr.: (A) Foot mounted - End shield	Ins. Cl.: F	Motor Prot.: (A) Without Protection	NEMA Des.: B	S.F.: 1.15
Mtr WT: 2,018 lbs	Mounting: (3) F-1, Standard Floor Mount, T. Box LHS	Temp. Rise Cl.: B	Amb. Temp.: +40 to -20 °C @1000 m	kVA: G	IP55

### Mechanical data

#### WK2

Rotor Moment of Inertia:	0	Lb-ft <sup>2</sup>
Ext Load Inertia Capability:	2920.0	Lb-ft <sup>2</sup>

#### Safe Stall Time

Hot:	20.0	s
Cold:	30.0	s

#### Typical Noise Data

A-weighted Sound		
Sound Pressure:	75.0	dB(A)
Sound Power:	64.0	dB(A)

#### Octave Band Center Frequencies Hertz

	250	500	1000	2000	4000	8000	Hz
SPL@3 feet	55.0	59.0	60.0	57.0	50.0	42.0	dB(A)

#### Bearings

	DE	NDE
Bearing size:	NU 320	6316 Z C3 S0
Bearing Type:	Roller Bearing	Ball Bearing
AFBMA:	100RU03M0	80BC03JP30

#### Grease

Capacity:	14.50	oz	7.50	oz
Type:	Exxon Mobile EM			
Thickener:	Polyurea			

#### Frame

Frame material:	cast iron
Coating (paint finish):	Standard Paint
Color, paint shade:	RAL 7030

#### Terminal box

Terminal box position:	(3) F-1, Standard Floor Mount, T. Box LHS
------------------------	---

#### Lead Wire Connection

Description:	6 LEAD - DELTA				
Voltage	L1	L2	L3	Connected together	
---	---	---	---	---	
---	T1	T2	T3	---	
				$\Delta$	

#### Ventilation Type

Type of Cooling:	TEFC
Fan Material:	Polypropylen ESD
Fan Rotation:	Bidirectional

#### Additional information

VFD Operation:	CT: 4:1	VT: 20:1
Area: classification:	Class I Division 2 Gr. A, B, C or D	

#### Notes

I<sub>L</sub>/I<sub>N</sub> = locked rotor current / current nominal T<sub>k</sub>/T<sub>N</sub> = break down torque / nominal torque  
 T<sub>A</sub>/T<sub>N</sub> = locked rotor torque / torque nominal <sup>1)</sup> Value is valid only for DOL operation with motor design IC411

Technical data are subject to change! There may be discrepancies between calculated and rating plate values.

Generated:  
2020-07-06 19:58

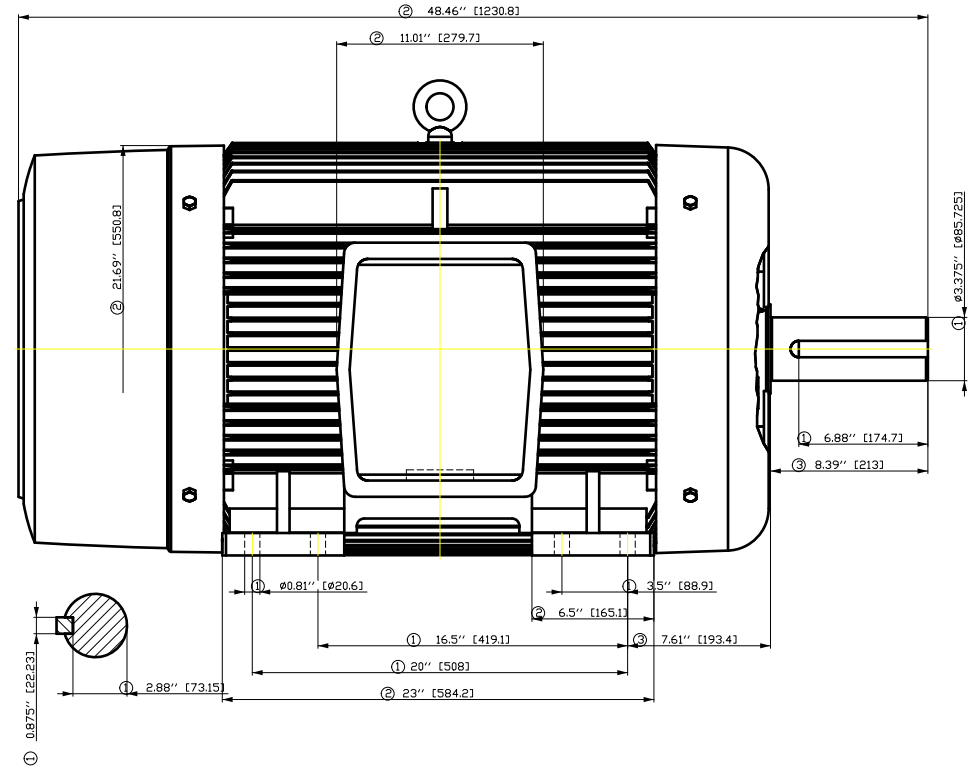
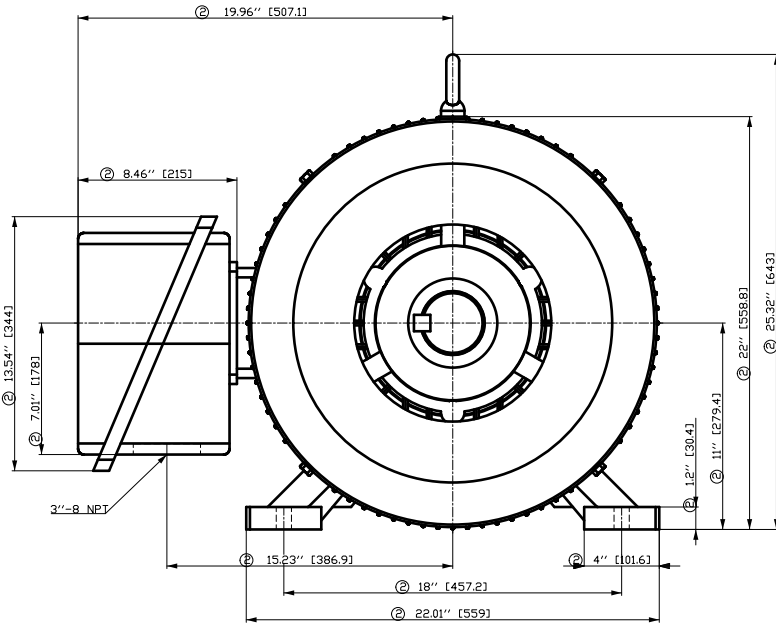

- ① Tolerances according to NEMA std.
- ② All these dimensions corresponding to assemblies and castings shall have a tolerance as per DIN standard 1686-GTB 19.
- ③ Not according to NEMA std.

Tolerance	Surface	Material	Weight	Scale
F50G GF8 ÖÖ-F800H E	Author Creator Approval Department Change Order	ÖS T a : ^ & @ } *	E	{ {
SIEMENS © Siemens AG 2018	Doc. State Revision	i 80E Index RS	MFB Item No Doc No	Doc Type Paper Size 1st Language 2nd Language
	Project No	E	Ref No	E
				F of F

# SIEMENS INDUSTRY, INC

HP 125 VOLTS < 600V RPM 900 TYPE SD100 IEEE841  
HZ 60 PHASE 3 FRAME 447T NEMA B

## TORQUE & CURRENT VS. SPEED

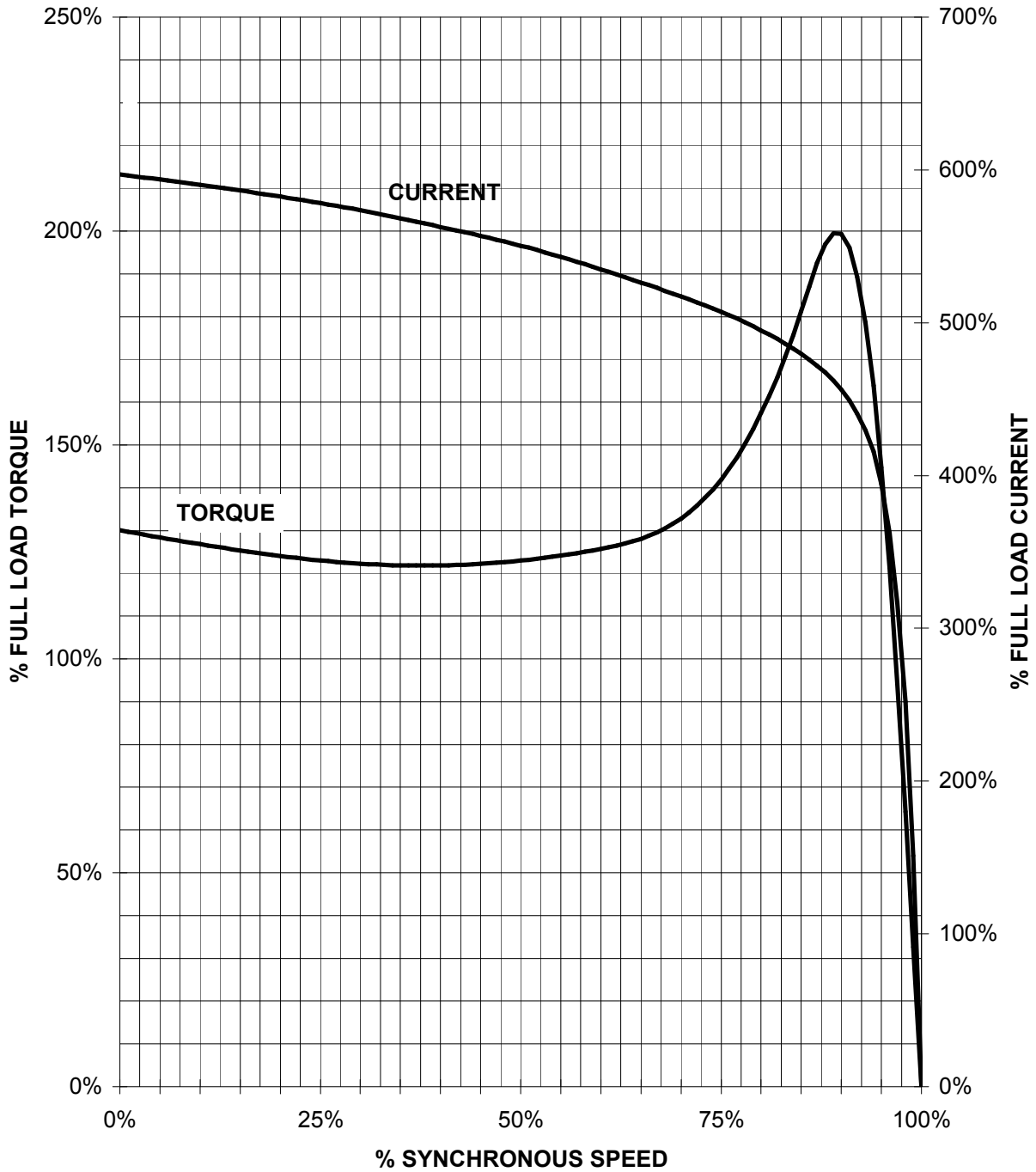

CUSTOMER: \_\_\_\_\_ ORDER#: \_\_\_\_\_

125 HP 900 RPM 447T FRAME 460 VOLTS 3 PHASE NEMA DESIGN B

**SIEMENS INDUSTRY, INC.**  
**PERFORMANCE CURVE**  
**SD100 IEEE841**

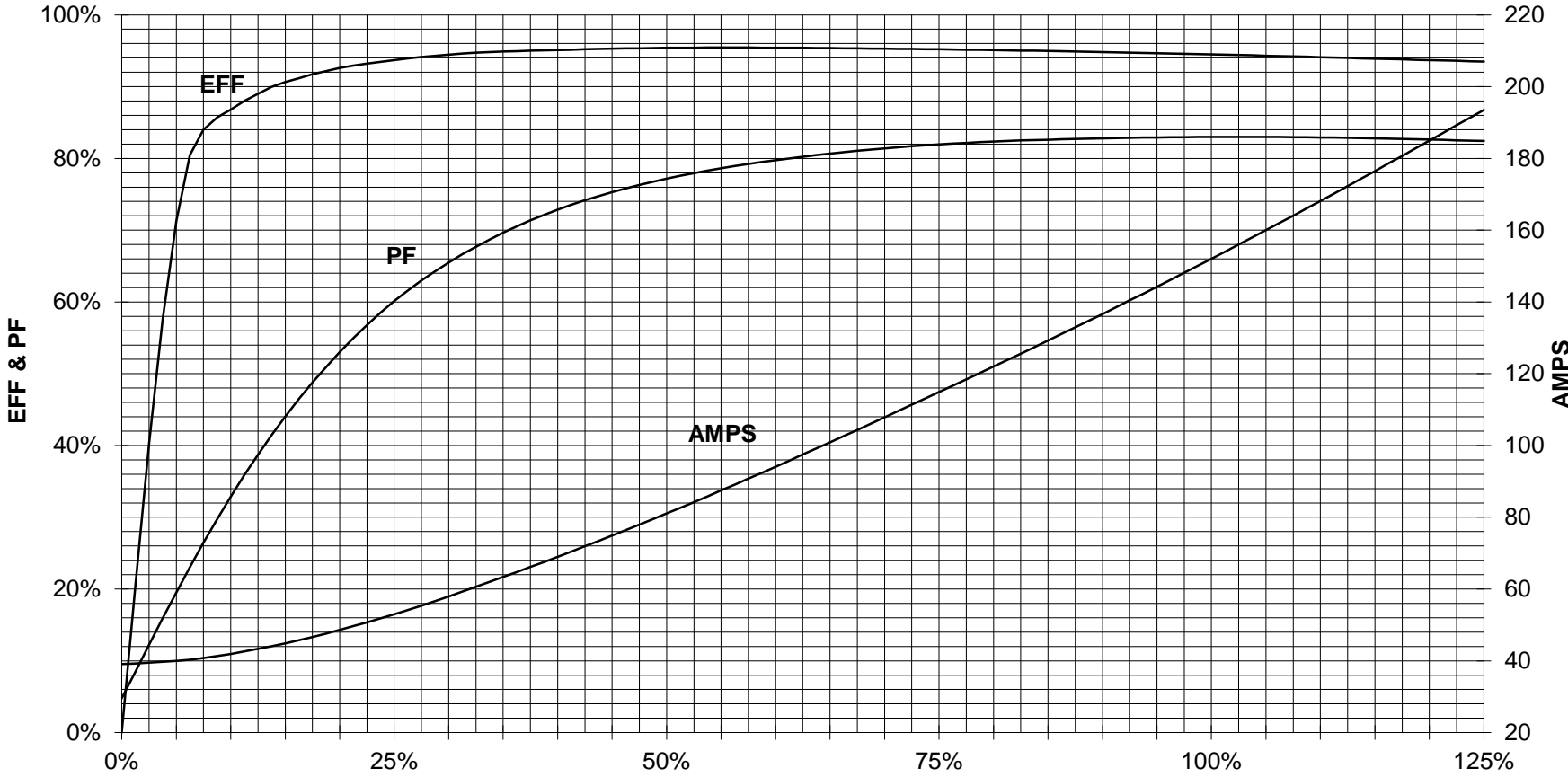

CUSTOMER \_\_\_\_\_ ORDER # \_\_\_\_\_ HORSEPOWER \_\_\_\_\_ PO # \_\_\_\_\_

PERFORMANCE BASED ON DESIGN CALCULATIONS. SUBJECT TO CHANGE WITHOUT NOTICE.

Main terminal diagram

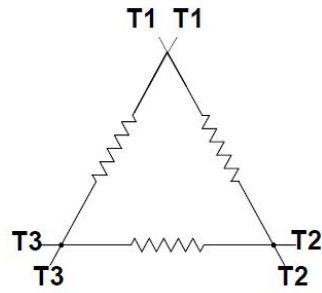

6 LEAD DELTA			
LINES			CONN.
L1	L2	L3	
T1	T2	T3	Δ

responsible dep. DI MC LVM	technical reference	created by	approved by	project
	document type Wiring Diagram		document status free	
	title 1LE2421-4CD31-2AA3		document number	
© Siemens AG 2019		rev. 01	creation date 12/03/2019	language Page en/en 1/1