



Data sheet for three-phase Squirrel-Cage-Motors

Totally Enclosed Fan Cooled (TEFC)

MLFB-Ordering data: **1LE2221-2AC21-4EA3**

Motor type: **GP100 - NEMA Premium Efficiency**

Client order no.:

Order no.:

Offer no.:

Remarks:

Item no.:

Consignment no.:

Project:

U [V]	Δ / Y	f [Hz]	P [HP]	P [kW]	n [rpm]	I Load [Amps]					LRC	Nom. Eff Load [%]			Pwr. Factor Load [%]			Torque [lb-ft]	T _A /T _N LRT [%]	T _k /T _N BDT [%]
						4/4	3/4	1/2	0	4/4		3/4	1/2	4/4	3/4	1/2				
460	Y	60	5.00	4.00	1,165	6.70	5.50	4.40	3.50	46.0	89.5	90.1	89.5	78.1	71.4	59.4	26.5	189	325	
230	YY	60	5.00	4.00	1,165	13.40	10.92	8.81	7.00	92.0	89.5	90.1	89.5	78.1	71.4	59.4	26.5	189	325	

Frame Type 215TC	Type of constr.: (E) Foot mounted - C-Face	Ins. Cl.: F	Motor Prot.: (A) Without Protection	NEMA Des.: B	S.F.: 1.15
Mtr WT: 171 lbs	Mounting: (3) F-1, Standard Floor Mount, T. Box LHS	Temp. Rise Cl.: B	Amb. Temp.: +40 to -20 °C @1000 m	kVA: J	IP55

Mechanical data

WK2

Rotor Moment of Inertia:	1	Lb-ft ²
Ext Load Inertia Capability:	71.0	Lb-ft ²

Safe Stall Time

Hot:	14.0	s
Cold:	21.0	s

Typical Noise Data

A-weighted Sound		
Sound Pressure:	71.0	dB(A)
Sound Power:	64.0	dB(A)

Octave Band Center Frequencies Hertz

	250	500	1000	2000	4000	8000	Hz
SPL@3 feet	42.0	52.0	64.0	54.0	47.0	34.0	dB(A)

Bearings

	DE	NDE
Bearing size:	6208 ZZ C3 S0	6208 ZZ C3 S0
Bearing Type:	Ball Bearing	Ball Bearing
AFBMA:	40BC02JPP30	40BC02JPP30

Grease

Capacity:	0.30	oz	0.30	oz
Type:	Exxon Mobile EM			
Thickener:	Polyurea			

Frame

Frame material:	cast iron
Coating (paint finish):	Standard Paint
Color, paint shade:	RAL 7030

Terminal box

Terminal box position:	(3) F-1, Standard Floor Mount, T. Box LHS
------------------------	-------------------------------------------

Lead Wire Connection

Description:	9 LEAD - WYE				
Voltage	L1	L2	L3	Connected together	
LOW	T1 T7	T2 T8	T3 T9	T4 T5 T6	Y Y
HIGH	T1	T2	T3	T4 T7-T5 T8-T6	Y
				T9	

Ventilation Type

Type of Cooling:	TEFC
Fan Material:	Polypropylen
Fan Rotation:	Bidirectional

Additional information

VFD Operation:	CT: 4:1	VT: 20:1
Area: classification:	without	

Notes

I_A/I_N = locked rotor current / current nominal T_k/T_N = break down torque / nominal torque
 T_A/T_N = locked rotor torque / torque nominal ¹⁾ Value is valid only for DOL operation with motor design IC411

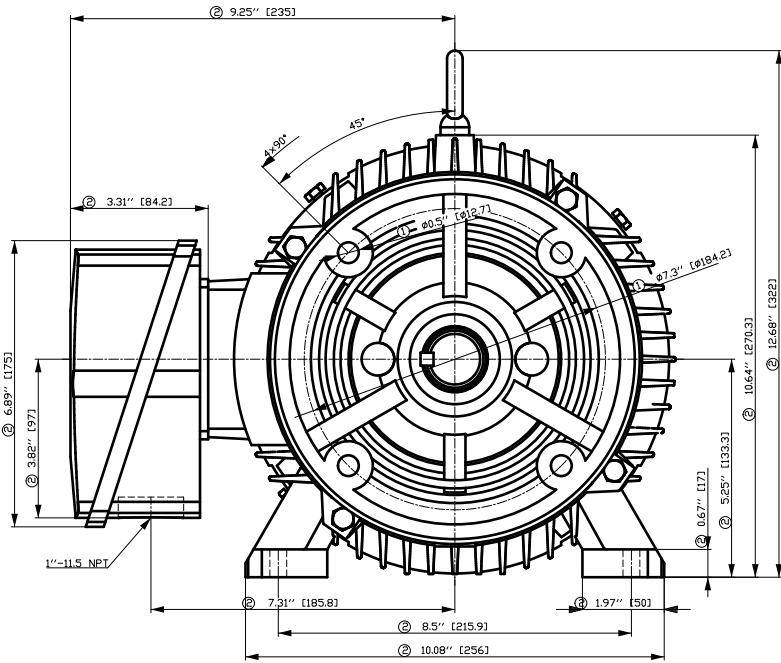

- ① Tolerances according to NEMA std.
- ② All these dimensions corresponding to assemblies and castings shall have a tolerance as per DIN standard 1686-GTB 19.
- ③ Not according to NEMA std.

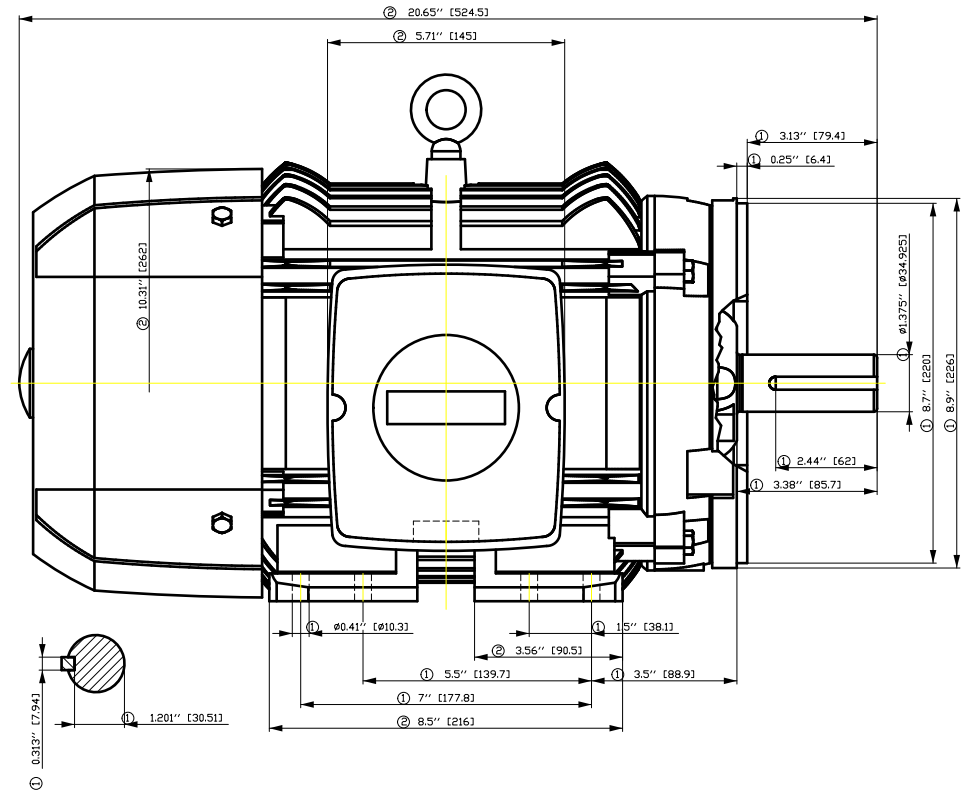

Tolerance	Surface	Material	Weight	Scale
F50CGEFC00GF00EH	Author	ÖV	1.375" [34.95]	1:1
E	Creator	T a : ^ @ ~ } *	8.7" [220]	1:1
	Approval		8.9" [226]	1:1
	Department			
	Change Order	MFB		
	Doc. State	i 00€		
	Revision	Index RS		
© Siemens AG 2018	Project No	E		
	Ref No	E		
	Doc Type			
	Paper Size	CH		
	1st Language	^		
	2nd Language	â		
	Sheet	F of F		

SIEMENS INDUSTRY, INC.

HP 5 VOLTS < 600V RPM 1200 TYPE GP100
HZ 60 PHASE 3 FRAME 215T NEMA B

TORQUE & CURRENT VS. SPEED

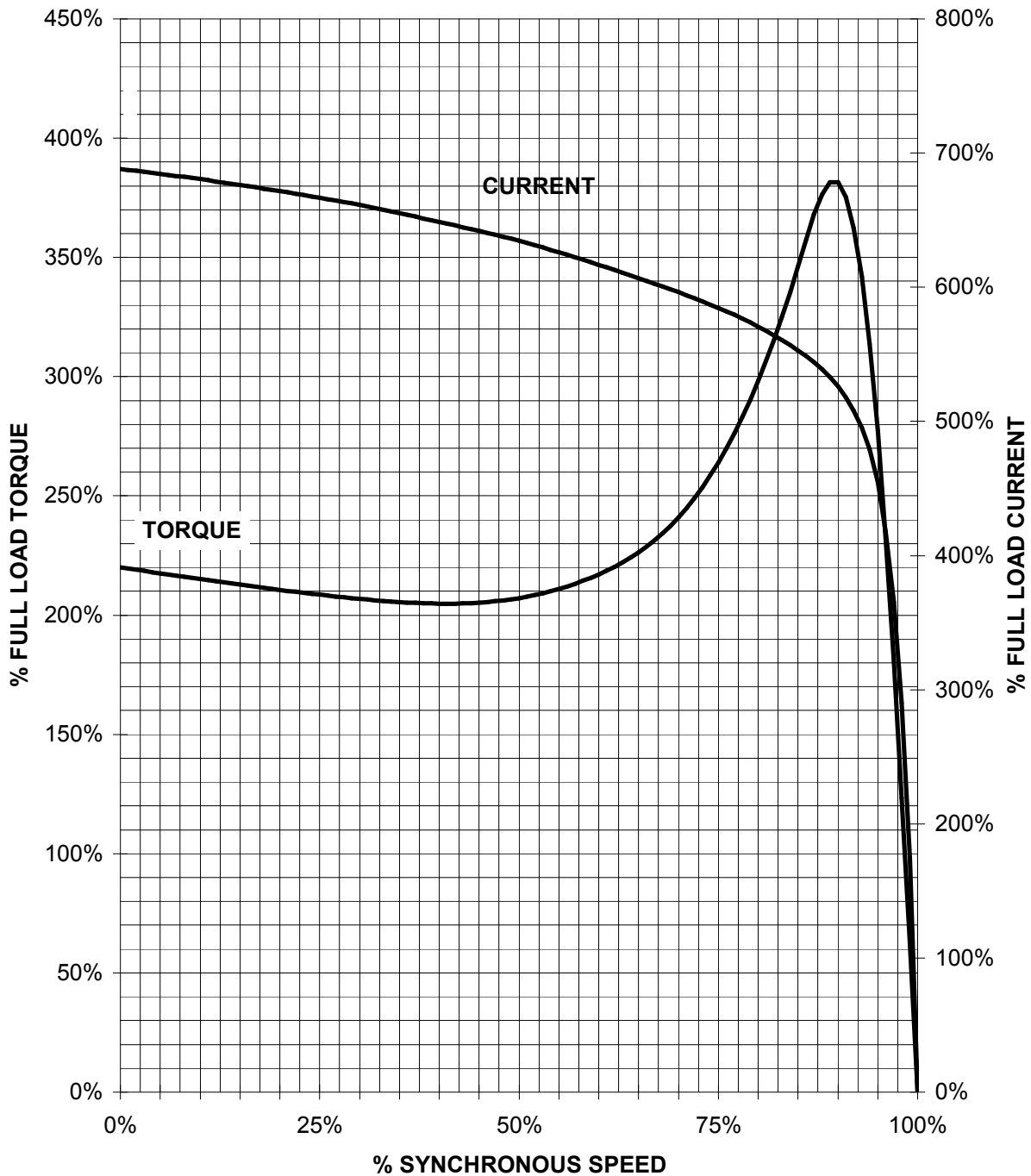

CUSTOMER: _____ ORDER#: _____

5 HP 1200 RPM 215T FRAME 460 VOLTS 3 PHASE NEMA DESIGN B

SIEMENS INDUSTRY, INC.
PERFORMANCE CURVE
GP100

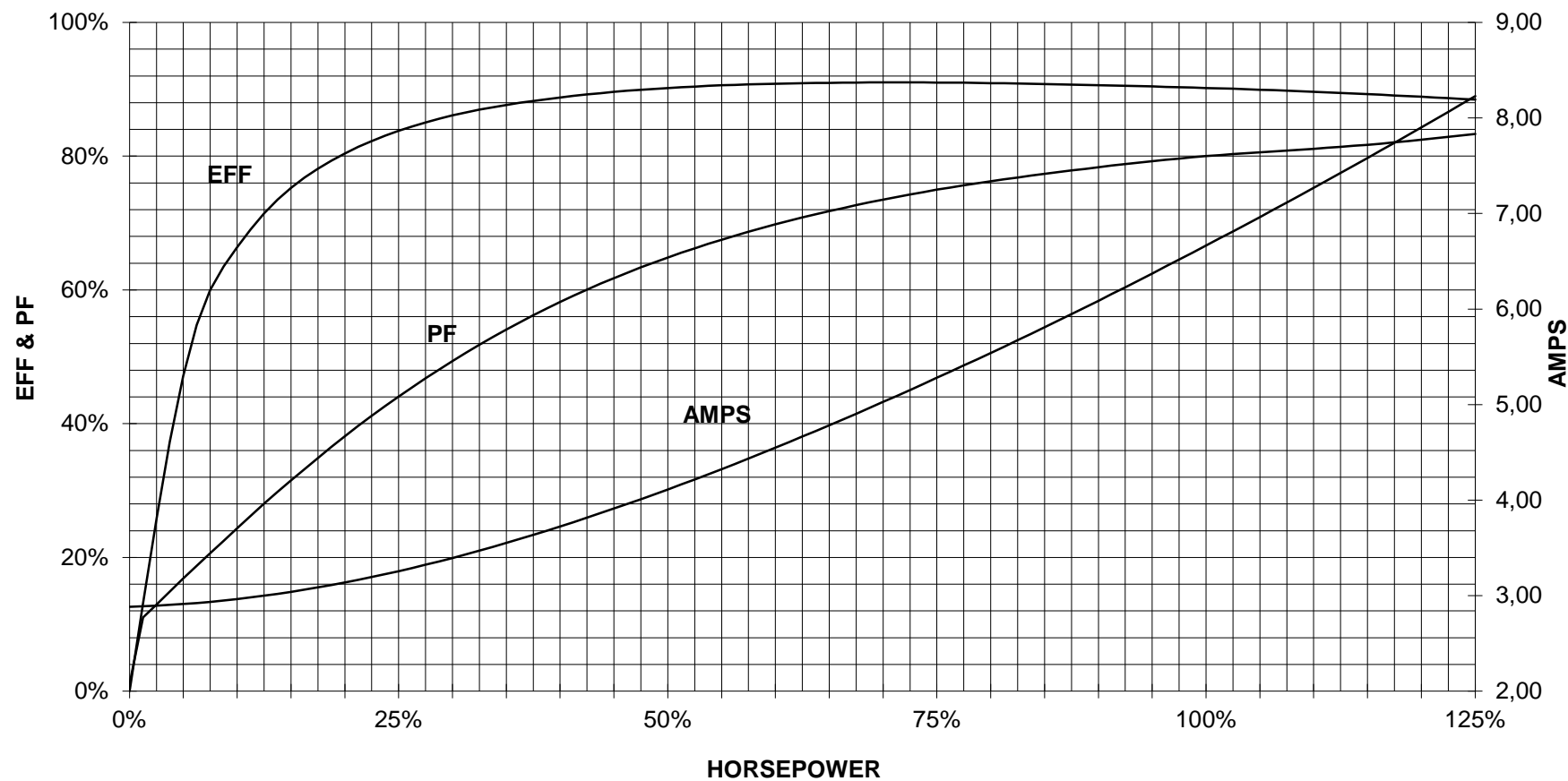

CUSTOMER _____ ORDER # _____ PO # _____

PERFORMANCE BASED ON DESIGN CALCULATIONS. SUBJECT TO CHANGE WITHOUT NOTICE.

REV. 1

Main terminal diagram

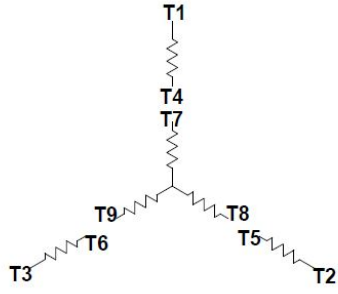

9 LEAD WYE						
Volts	LINES			CONNECTED TOGETHER	CONN.	
	L1	L2	L3			
LOW	T1 T7	T2 T6	T3 T9	T4 T5 T6	YY	
HIGH	T1	T2	T3	T4 T7-T5 T8-T6 T9	Y	

responsible dep. DI MC LVM	technical reference	created by	approved by	project
SIEMENS	document type Wiring Diagram	document status free		customer
	title 1LE2221-2AC21-4EA3	document number		
© Siemens AG 2019	rev. 01	creation date 12/03/2019	language en/en	Page 1/1