



## Data sheet for three-phase Squirrel-Cage-Motors

Totally Enclosed Fan Cooled (TEFC)

MLFB-Ordering data: **1LE2211-1AB41-4AA3**

Motor type: **GP100 - NEMA Premium Efficiency Plus**

Client order no.:

Order no.:

Offer no.:

Remarks:

Item no.:

Consignment no.:

Project:

U [V]	$\Delta / Y$	f [Hz]	P [HP]	P [kW]	n [rpm]	I Load [Amps]					LRC	Nom. Eff Load [%]			Pwr. Factor Load [%]			Torque [lb-ft]	T <sub>A</sub> /T <sub>N</sub> LRT [%]	T <sub>k</sub> /T <sub>N</sub> BDT [%]
						4/4	3/4	1/2	0	4/4		3/4	1/2	4/4	3/4	1/2				
460	Y	60	2.00	1.50	1,765	2.80	2.30	2.00	1.60	25.0	87.5	87.5	86.0	78.0	69.0	55.0	6.0	233	433	
230	YY	60	2.00	1.50	1,765	5.60	4.65	3.96	3.20	50.0	87.5	87.5	86.0	78.0	69.0	55.0	6.0	233	433	

Frame Type 145T	Type of constr.: ( A ) Foot mounted - End shield	Ins. Cl.: F	Motor Prot.: (A) Without Protection	NEMA Des.: B	S.F.: 1.15
Mtr WT: 68 lbs	Mounting: (3) F-1, Standard Floor Mount, T. Box LHS	Temp. Rise Cl.: B	Amb. Temp.: +40 to -20 °C @1000 m	kVA: L	IP55

## Mechanical data

### WK2

Rotor Moment of Inertia:	0	Lb-ft <sup>2</sup>
Ext Load Inertia Capability:	11.0	Lb-ft <sup>2</sup>

### Safe Stall Time

Hot:	15.0	s
Cold:	21.0	s

### Typical Noise Data

A-weighted Sound		
Sound Pressure:	62.0	dB(A)
Sound Power:	50.0	dB(A)

### Octave Band Center Frequencies Hertz

	250	500	1000	2000	4000	8000	Hz
SPL@3 feet	37.0	40.0	49.0	45.0	37.0	31.0	dB(A)

### Bearings

	DE	NDE
Bearing size:	6205 ZZ C3 S0	6205 ZZ C3 S0
Bearing Type:	Ball Bearing	Ball Bearing
AFBMA:	25BC02JPP30	25BC02JPP30

### Grease

Capacity:	0.10	oz	0.10	oz
Type:	Exxon Mobile EM			
Thickener:	Polyurea			

### Frame

Frame material:	cast iron
Coating (paint finish):	Standard Paint
Color, paint shade:	RAL 7030

### Terminal box

Terminal box position:	(3) F-1, Standard Floor Mount, T. Box LHS
------------------------	---

### Lead Wire Connection

Description:	9 LEAD - WYE				
Voltage	L1	L2	L3	Connected together	
LOW	T1 T7	T2 T8	T3 T9	T4 T5 T6	Y Y
HIGH	T1	T2	T3	T4 T7-T5 T8-T6	Y
				T9	

### Ventilation Type

Type of Cooling:	TEFC
Fan Material:	Polypropylen
Fan Rotation:	Bidirectional

### Additional information

VFD Operation:	CT: 10:1	VT: 20:1
Area: classification:	without	

### Notes

I<sub>A</sub>/I<sub>N</sub> = locked rotor current / current nominal T<sub>k</sub>/T<sub>N</sub> = break down torque / nominal torque  
 T<sub>A</sub>/T<sub>N</sub> = locked rotor torque / torque nominal <sup>1)</sup> Value is valid only for DOL operation with motor design IC411

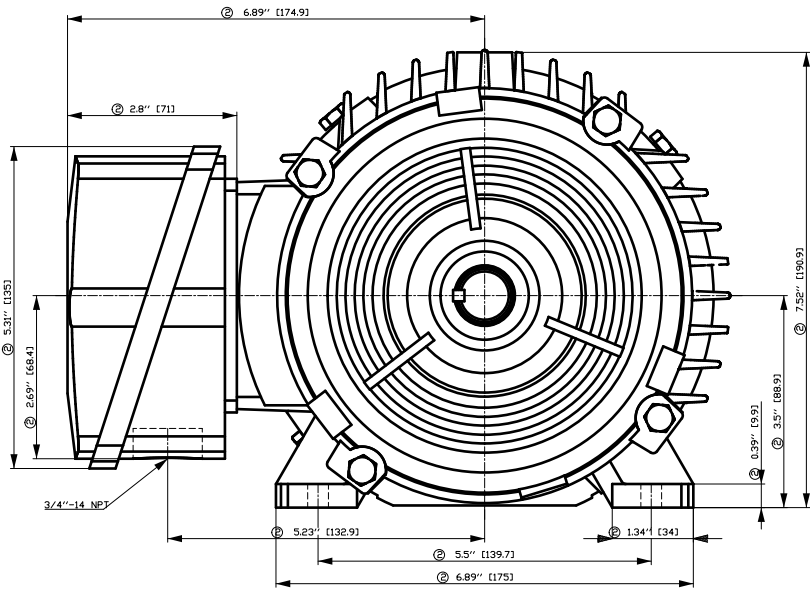

- ① Tolerances according to NEMA std.
- ② All these dimensions corresponding to assemblies and castings shall have a tolerance as per DIN standard 1686-GTB 19.
- ③ Not according to NEMA std.

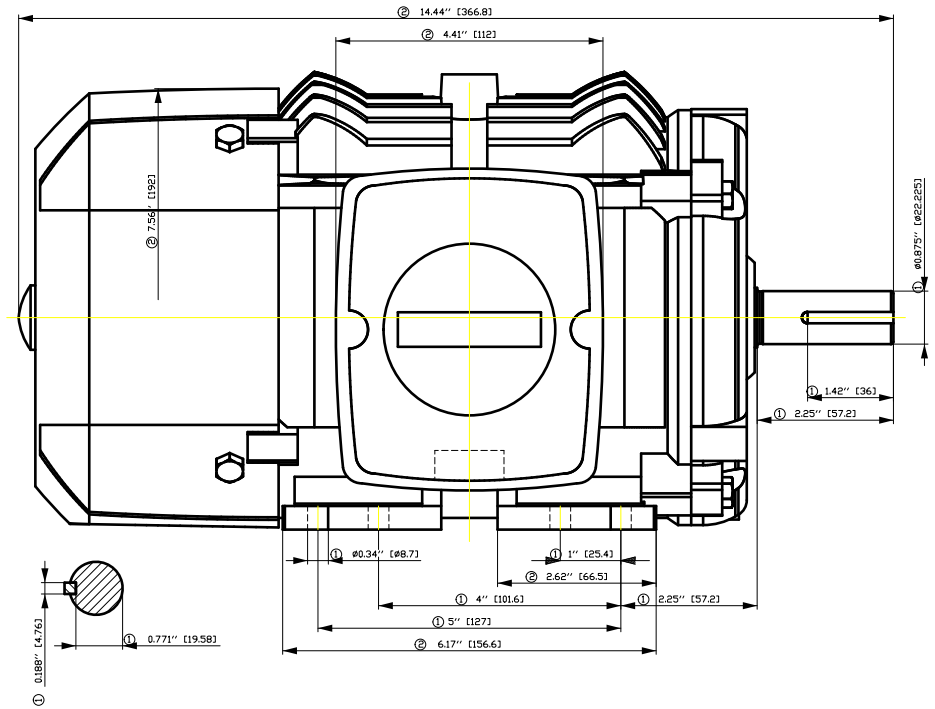

Tolerance	Surface	Material	Weight	Scale
F50GFFFE01 F8 CDEH	Author	ÖS T a : ^ & @ } *	E	
E	Creator			
	Approval			
	Department			
	Change Order	MLFB	Doc Type	/
	Doc State	i 0 0 E	Item No	Paper Size
	Revision	Index RS	Doc No	1st Language
				2nd Language
© Siemens AG 2018	Project No	E	Ref No	E
				Sheet F of F

# SIEMENS INDUSTRY, INC.

HP 2 VOLTS < 600V RPM 1800 TYPE GP100 NPP  
HZ 60 PHASE 3 FRAME 145T NEMA B

## TORQUE & CURRENT VS. SPEED

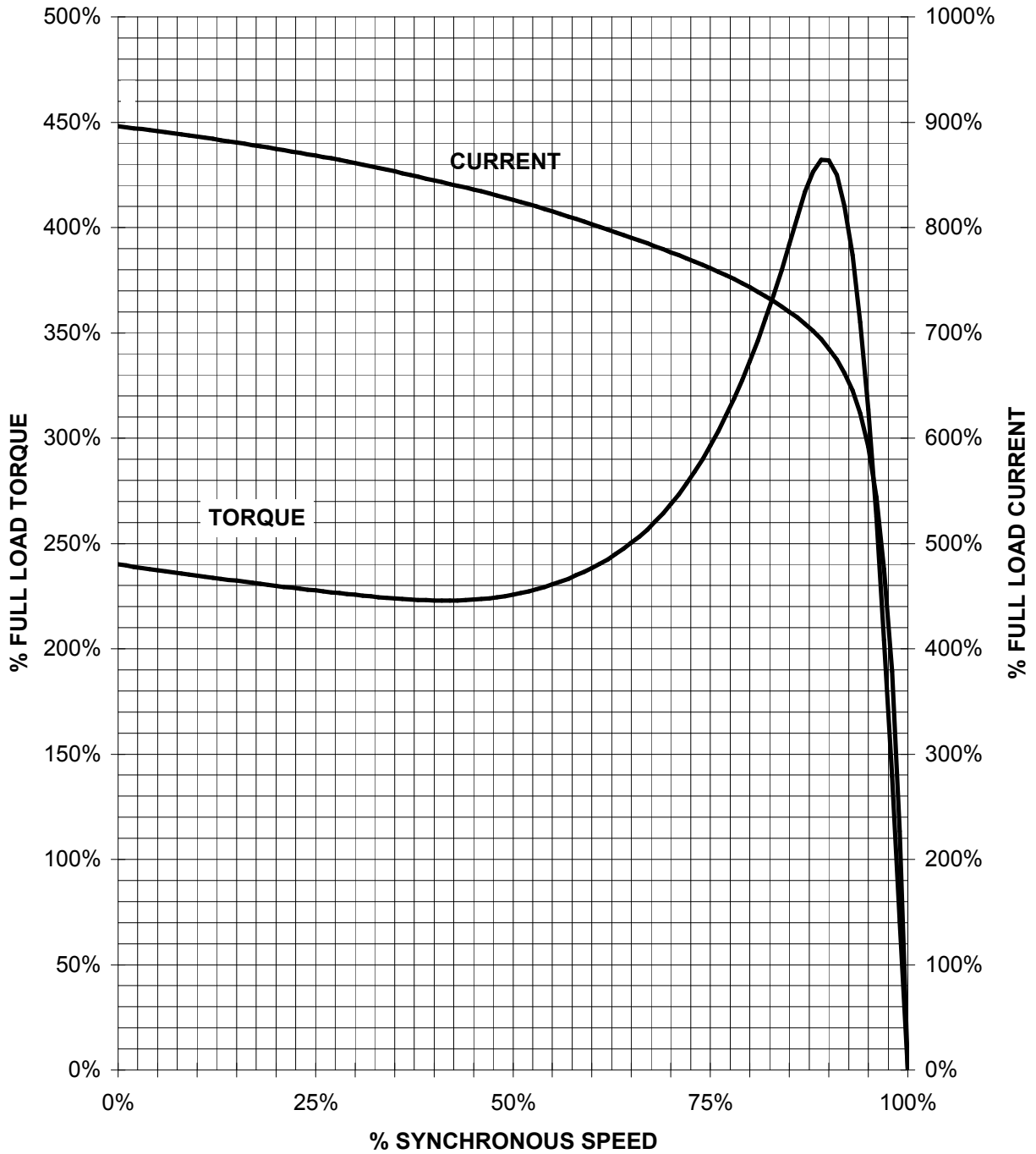

CUSTOMER: \_\_\_\_\_ ORDER#: \_\_\_\_\_

2 HP 1800 RPM 145 FRAME 460 VOLTS 3 PHASE NEMA DESIGN B

**SIEMENS INDUSTRY, INC.**  
**PERFORMANCE CURVE**  
**GP100 NPP**

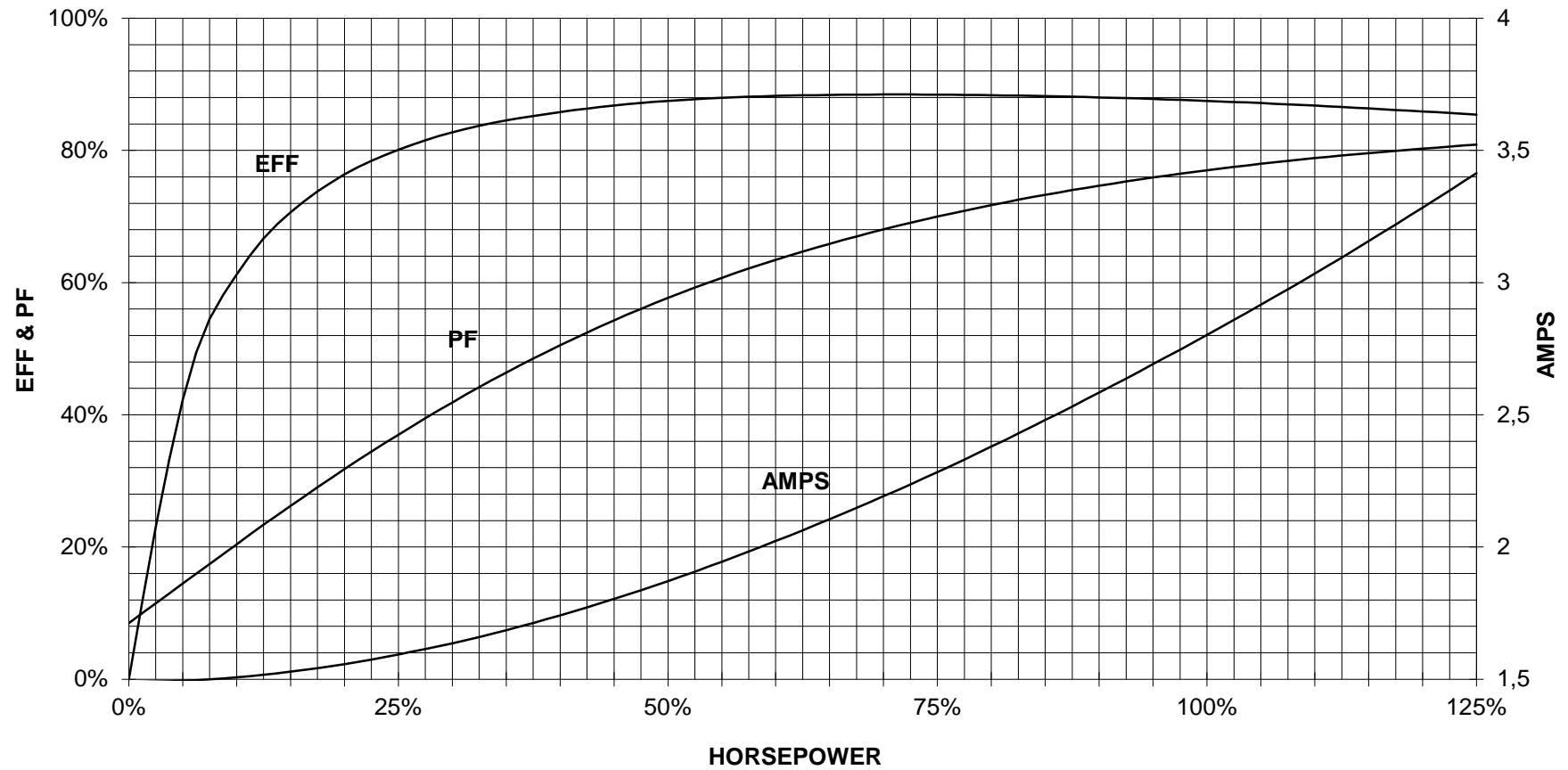

CUSTOMER \_\_\_\_\_ ORDER # \_\_\_\_\_ PO # \_\_\_\_\_

PERFORMANCE BASED ON DESIGN CALCULATIONS. SUBJECT TO CHANGE WITHOUT NOTICE.

REV. 1

Main terminal diagram

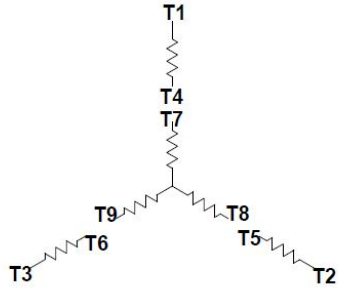

9 LEAD WYE						
Volts	LINES			CONNECTED TOGETHER	CONN.	
	L1	L2	L3			
LOW	T1 T7	T2 T6	T3 T9	T4 T5 T6	YY	
HIGH	T1	T2	T3	T4 T7-T5 T8-T6 T9	Y	

responsible dep. DI MC LVM	technical reference	created by	approved by	project	
	document type Wiring Diagram		document status free		customer
	title 1LE2211-1AB41-4AA3		document number		
© Siemens AG 2019		rev. 01	creation date 12/03/2019	language en/en	Page 1/1