



## Data sheet for three-phase Squirrel-Cage-Motors

Totally Enclosed Fan Cooled (TEFC)

**MLFB-Ordering data:** 1LE2121-1CA31-4GA3

**Motor type:** GP100A - NEMA Premium Efficiency

Client order no.:

Order no.:

Offer no.:

Remarks:

Item no.:

Consignment no.:

Project:

U [V]	$\Delta/Y$	f [Hz]	P [HP]	P [kW]	n [rpm]	I Load [Amps]					LRC	Nom. Eff Load [%]			Pwr. Factor Load [%]			Torque [lb-ft]	$T_A/T_N$ LRT [%]	$T_k/T_N$ BDT [%]
						4/4	3/4	1/2	0	4/4		3/4	1/2	4/4	3/4	1/2				
460	Y	60	5.00	4.00	3,505	6.00	4.60	3.40	2.00	46.0	88.5	89.1	88.2	88.2	85.9	78.1	7.5	173	427	
230	YY	60	5.00	4.00	3,505	12.00	9.18	6.80	4.00	92.0	88.5	89.1	88.2	88.2	85.9	78.1	7.5	173	427	

Frame Type 184TC	Type of constr.: (G) Round body - C-Face	Ins. Cl.: F	Motor Prot.: (A) Without Protection	NEMA Des.: B	S.F.: 1.15
Mtr WT: 79 lbs	Mounting: (3) F-1, Standard Floor Mount, T. Box LHS	Temp. Rise Cl.: B	Amb. Temp.: +40 to -20 °C @1000 m	kVA: J	IP55

### Mechanical data

#### WK2

Rotor Moment of Inertia: 0 Lb-ft<sup>2</sup>

Ext Load Inertia Capability: 5.7 Lb-ft<sup>2</sup>

#### Safe Stall Time

Hot: 15.0 s

Cold: 29.0 s

#### Typical Noise Data

##### A-weighted Sound

Sound Pressure: 81.0 dB(A)

Sound Power: 69.0 dB(A)

##### Octave Band Center Frequencies Hertz

	250	500	1000	2000	4000	8000	Hz
SPL@3 feet	49.0	61.0	66.0	64.0	60.0	50.0	dB(A)

#### Bearings

	DE	NDE
Bearing size:	6206 ZZ C3 S0	6206 ZZ C3 S0
Bearing Type:	Ball Bearing	Ball Bearing
AFBMA:	30BC02JPP30	30BC02JPP30

#### Grease

Capacity:	0.20 oz	0.20 oz
Type:	Exxon Mobile EM	
Thickener:	Polyurea	

#### Frame

Frame material:	aluminum
Coating (paint finish):	Standard Paint
Color, paint shade:	RAL 7030

#### Terminal box

Terminal box position: (3) F-1, Standard Floor Mount, T. Box LHS

#### Lead Wire Connection

Description:	9 LEAD - WYE				
Voltage	L1	L2	L3	Connected together	
LOW	T1 T7	T2 T8	T3 T9	T4 T5 T6	YY
HIGH	T1	T2	T3	T4 T7-T5 T8-T6 T9	Y

#### Ventilation Type

Type of Cooling:	TEFC
Fan Material:	Polypropylen
Fan Rotation:	Bidirectional

#### Additional information

VFD Operation:	CT: 4:1	VT: 20:1
Area: classification:	without	

#### Notes

$I_A/I_N$  = locked rotor current / current nominal  $T_k/T_N$  = break down torque / nominal torque  
 $T_A/T_N$  = locked rotor torque / torque nominal <sup>1)</sup> Value is valid only for DOL operation with motor design IC411

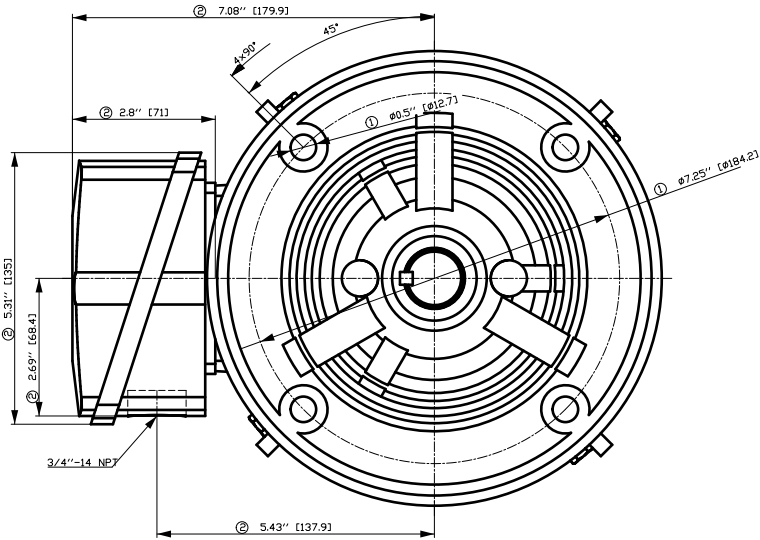

- ① Tolerances according to NEMA std.
- ② All these dimensions corresponding to assemblies and castings shall have a tolerance as per DIN standard 1686-GTB 19.
- ③ Not according to NEMA std.

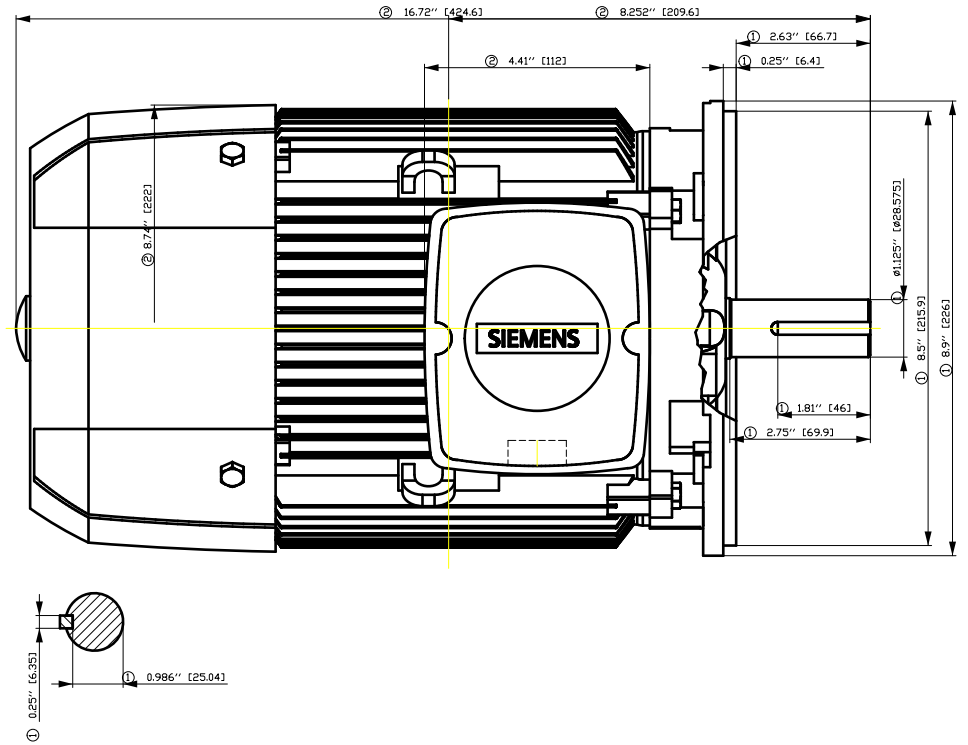

Tolerance	Surface	Material	Weight	Scale	
F50GFGF#00#F#00H	Author	ÖS T a : ^@` } *	E		
E	Creator				ÖVS
	Approval				
	Department				
	Change Order	MLFB		Doc Type	
SIEMENS	Doc State	FEP1 DE	Item No	Paper Size	
	Revision	Index RS	Doc No	1st Language ^ 2nd Language a^	
© Siemens AG 2018	Project No	E	Ref No	E	
				Sheet F of F	

# SIEMENS INDUSTRY, INC.

HP 5 VOLTS < 600V RPM 3600 TYPE GP100A  
HZ 60 PHASE 3 FRAME 184T NEMA B

## TORQUE & CURRENT VS. SPEED

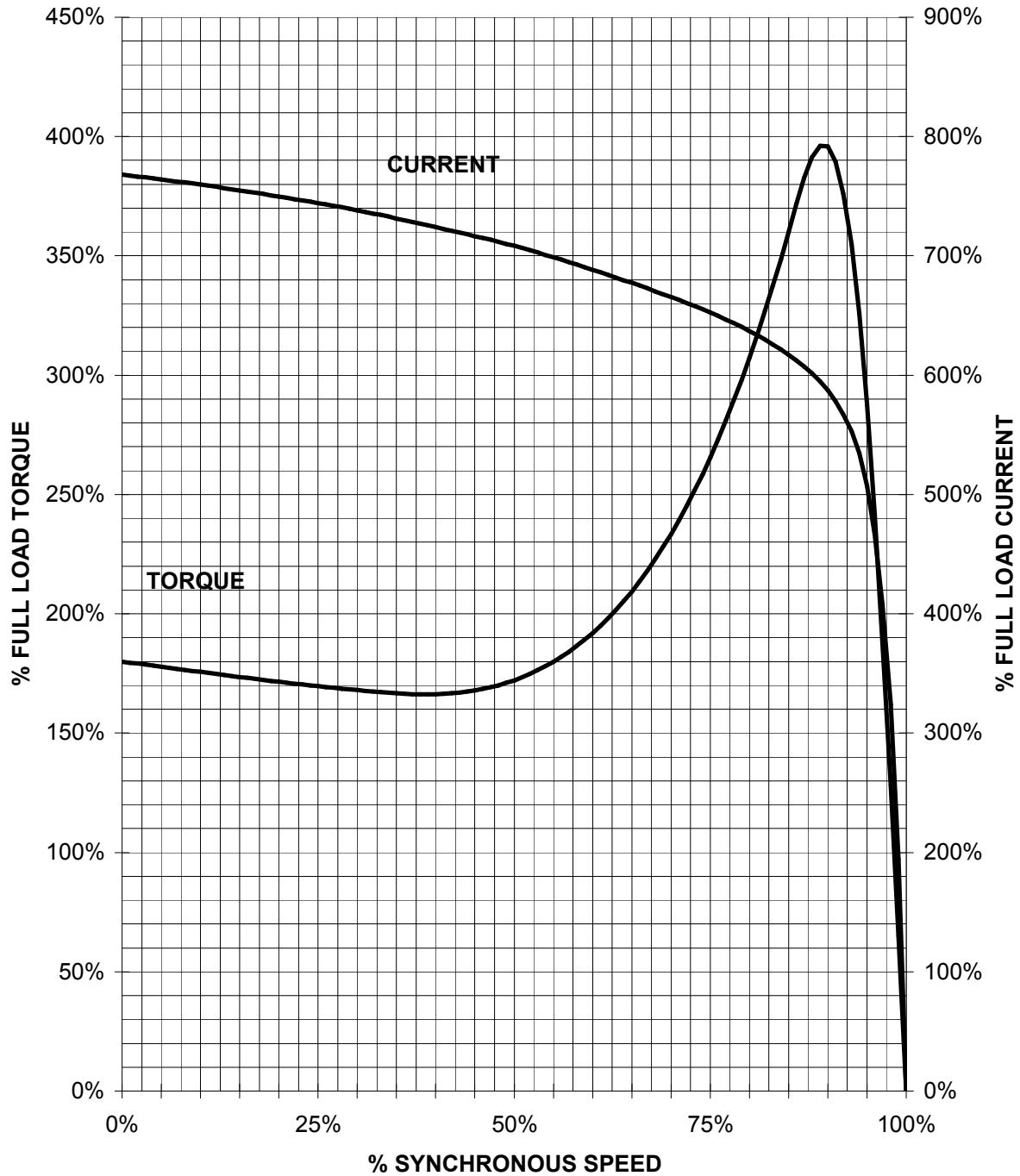

CUSTOMER: \_\_\_\_\_ ORDER#: \_\_\_\_\_

5 HP 3600 RPM 184 FRAME 460 VOLTS 3 PHASE NEMA DESIGN B

**SIEMENS INDUSTRY, INC.**  
**PERFORMANCE CURVE**  
**GP100A NP**

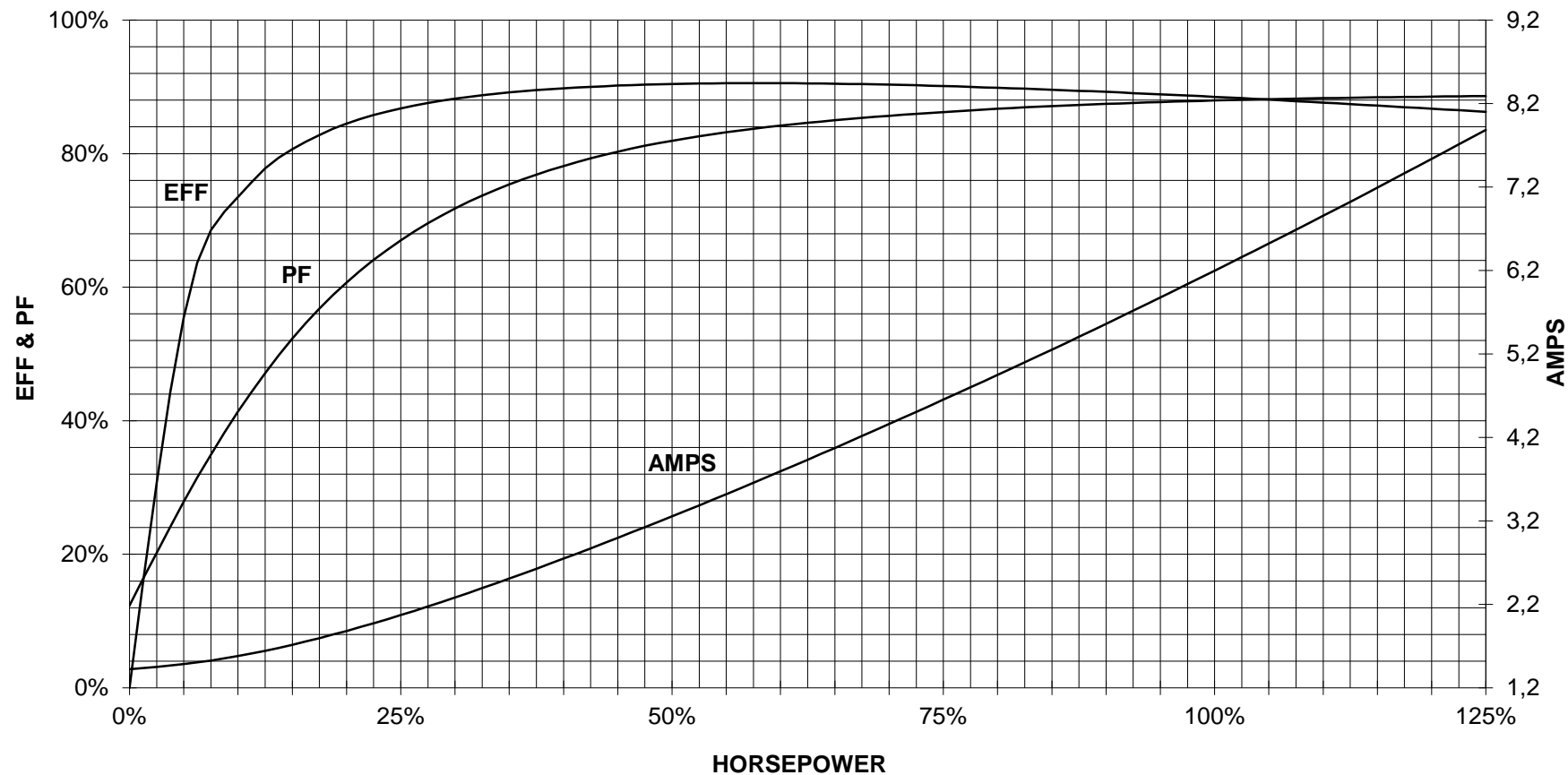

CUSTOMER \_\_\_\_\_ ORDER # \_\_\_\_\_ PO # \_\_\_\_\_

PERFORMANCE BASED ON DESIGN CALCULATIONS. SUBJECT TO CHANGE WITHOUT NOTICE.

REV. 1

Main terminal diagram

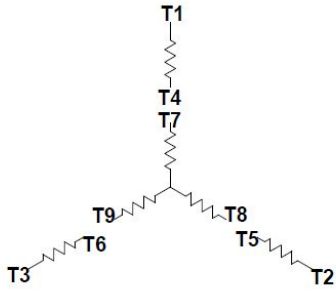

9 LEAD WYE						
Volts	LINES			CONNECTED TOGETHER	CONN.	
	L1	L2	L3			
LOW	T1 T7	T2 T6	T3 T9	T4 T5 T6	YY	
HIGH	T1	T2	T3	T4 T7-T5 T8-T6 T9	Y	

responsible dep. DI MC LVM	technical reference	created by	approved by	project
<b>SIEMENS</b>	document type Wiring Diagram	document status free		customer
	title 1LE2121-1CA31-4GA3	document number		
© Siemens AG 2019	rev. 01	creation date 12/03/2019	language en	Page 1/1