

RBC PROPRIETARY AND CONFIDENTIAL INFORMATION
 This document is the property of REGAL BELOIT CORPORATION ("RBC") including its subsidiaries and divisions and contains proprietary information of RBC. This document is loaned on the express condition that neither the information contained therein shall be disclosed to others without the express written consent of RBC, and that the information shall be used by the recipient only as approved expressly by RBC. This document shall be returned to RBC upon its request. This document may be subject to certain restrictions under U.S. export control laws and regulations.

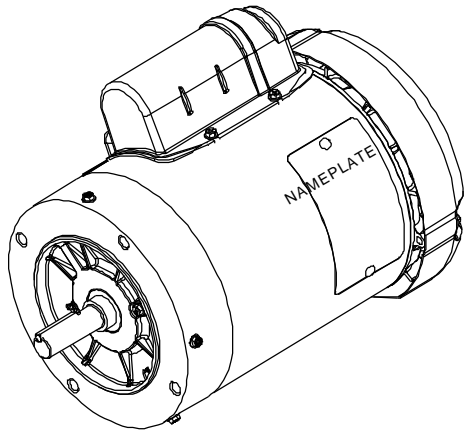
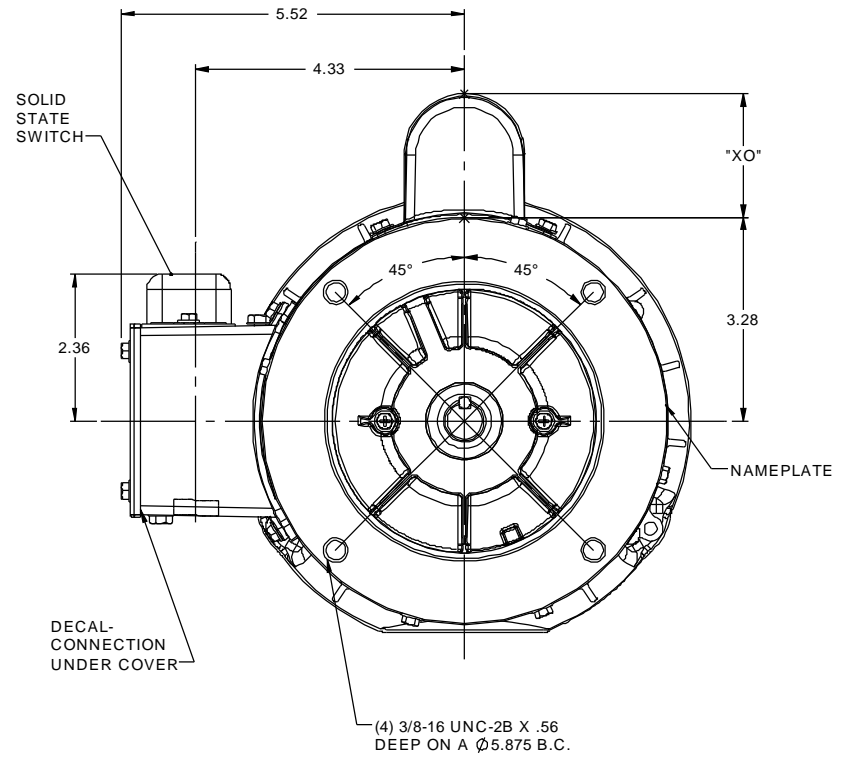
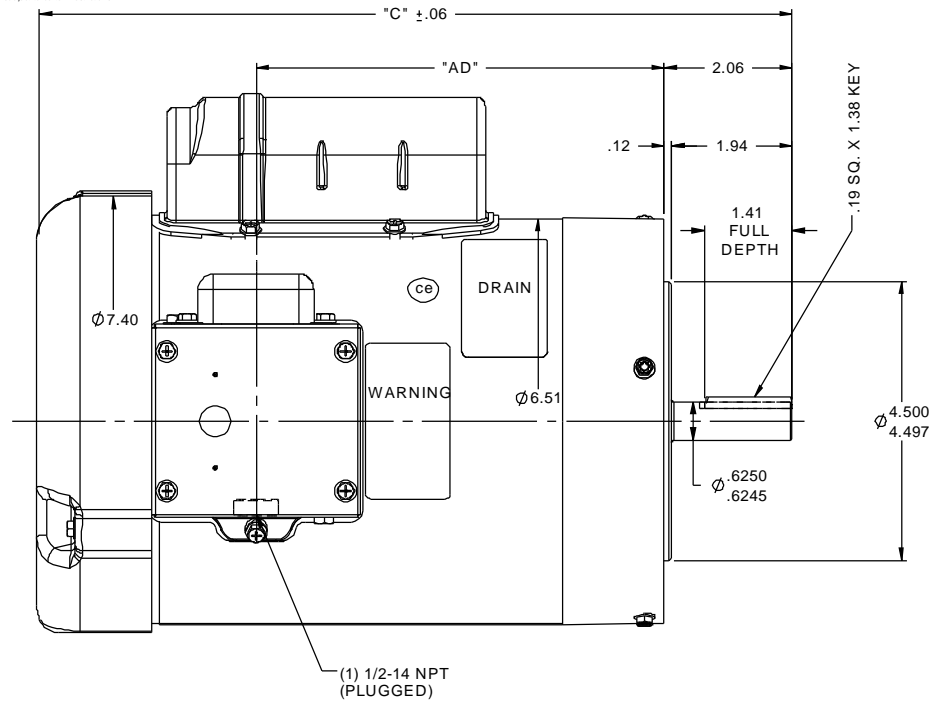

DASH NO.	"C"	"AD"
450	10.16	4.56
500	10.66	5.06
550	11.16	5.56
600	11.66	6.06
650	12.16	6.56
700	12.66	7.06

CAP. DASH	"XO"
A	1.54
B	2.01
C	2.25

SPECIAL FEATURES:
 1) SHAFT SEALS & V-RING
 2) DRAIN HOLES IN BOTH ENDBELLS & CONDUIT BOX
 3) GASKETS THROUGHOUT
 4) STAINLESS STEEL SHAFT, HARDWARE, & NAMEPLATE

MAXIMUM FACE RUNOUT .004 T.I.R.
 MAXIMUM PILOT ECCENTRICITY .004 T.I.R.
 PERMISSIBLE SHAFT RUNOUT .002 T.I.R.

		TOLERANCES UNLESS SPECIFIED			DRAWN LST 1/19/09
		DEC	INCHES		CHK
		X	±.1	APPR	
		XX	±.03	TITLE	SCALE 1:2
		XXX	±.005	OUTLINE - 56C FRAME	REF
01	UPDATED PER ECR 0034519	LST	4/26/2013	TEFC - "C" FACE	FMF
NO	REVISION	BY & DATE	CHK	MAT'L	PAGE OF
			ANG ±1/2°	FINISH	
THIRD ANGLE PROJECTION		RFP	PREV	NETWORK FILE NAME 028944	SIZE B
				DRAWING NO 028944	REV 01