

'W' = CLEARANCE ALLOWED FOR ALL VARIANCES
IN MANUFACTURING & ASSEMBLY

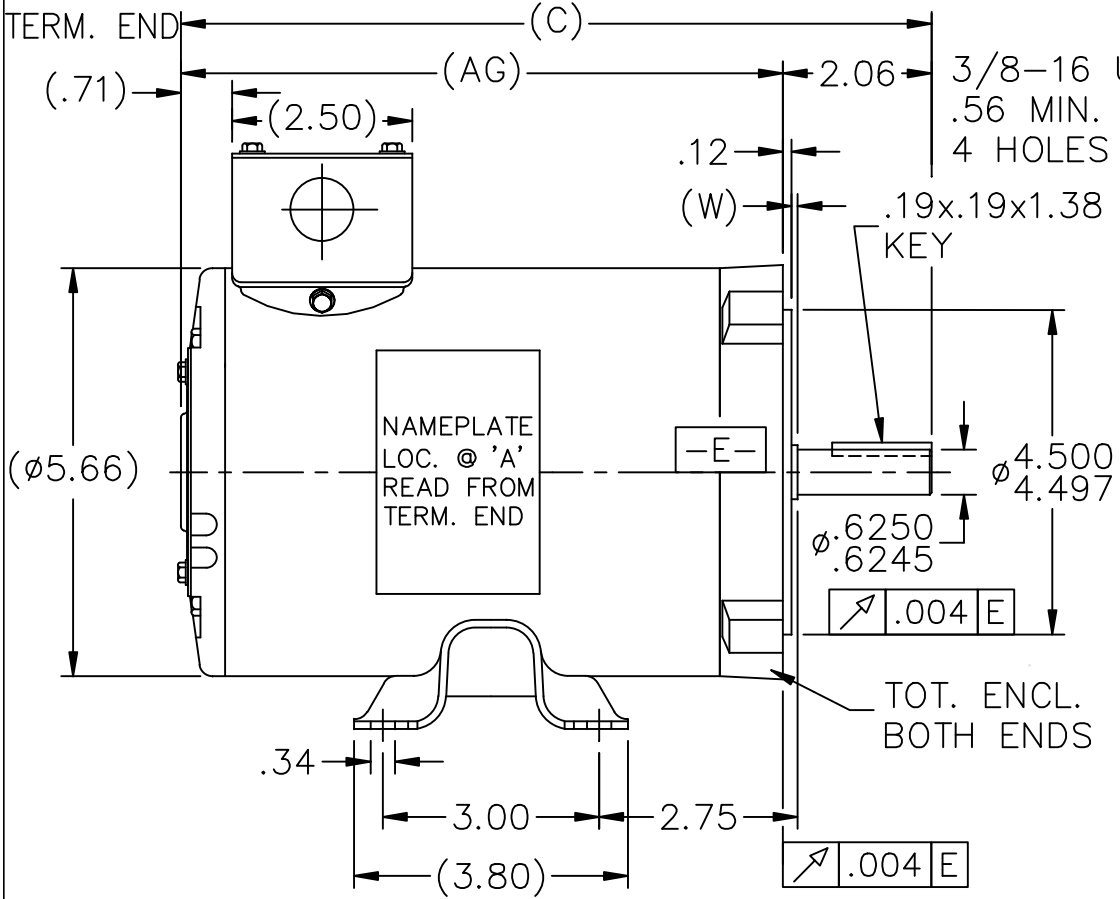

ø.88
KNOCKOUTS
5 PLACES

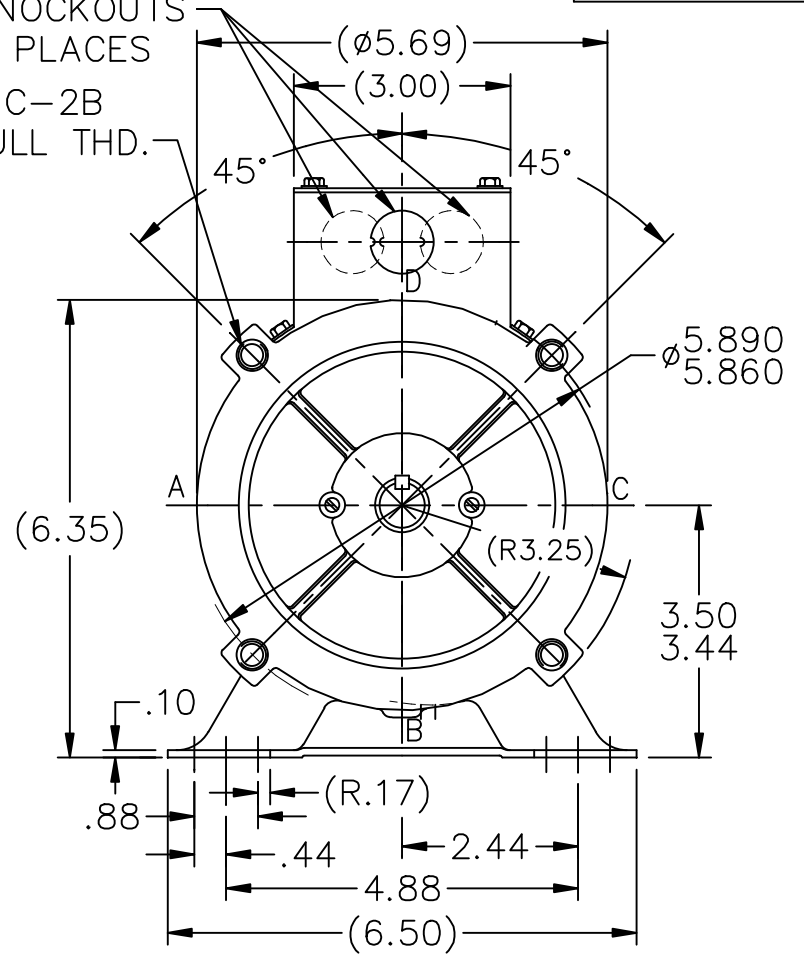

DASH	FR	C	AG	DASH	FR	C	AG	DASH	FR	C	AG
600	56	9.66	7.60	675	56	10.41	8.35	750	56	11.16	9.10
625	56	9.81	7.85	700	56	10.66	8.60	775	56	11.41	9.35
650	56	10.16	8.10	725	56	10.91	8.85				

TOLERANCES
UNLESS SPECIFIED

DEC.	INCHES
.X	±.1
.XX	±.03
.XXX	±.005
.XXXX	±.0005
ANG	±7'30"



DRAWN	TJB	01-14-2002
CHK	DRS	01-29-2002
APPD	TOM	01-30-2002
SCALE	3=8	
REF		
FMF		
PREV		

NO.	REVISION	BY & DATE	CHK	ANG
3	REVISED "C" & "AG" DIMS	ISAAC10-2047	TJW	7/27/2010
2	REDRAWN IN AUTOCAD		TAT	06-24-2005
1	NEW DRAWING CN 34675		TJB	01-30-2002

TITLE	OUTLINE
	56 FRAME
MAT'L.	
FINISH	

THIS DRAWING IN DESIGN AND DETAIL IS OUR PROPERTY AND MUST NOT BE USED EXCEPT IN CONNECTION WITH OUR WORK ALL RIGHTS OF DESIGN AND INVENTION ARE RESERVED THIS IS AN ELECTRONICALLY GENERATED DOCUMENT - DO NOT SCALE THIS PRINT		RFP	CAD FILE	ss403204	SIZE	DRAWING NO.	PAGE	OF	REV.
		DIST	WP		A	SS403204			3