

'W' = CLEARANCE ALLOWED FOR ALL VARIANCES  
IN MANUFACTURING & ASSEMBLY.

SS75175

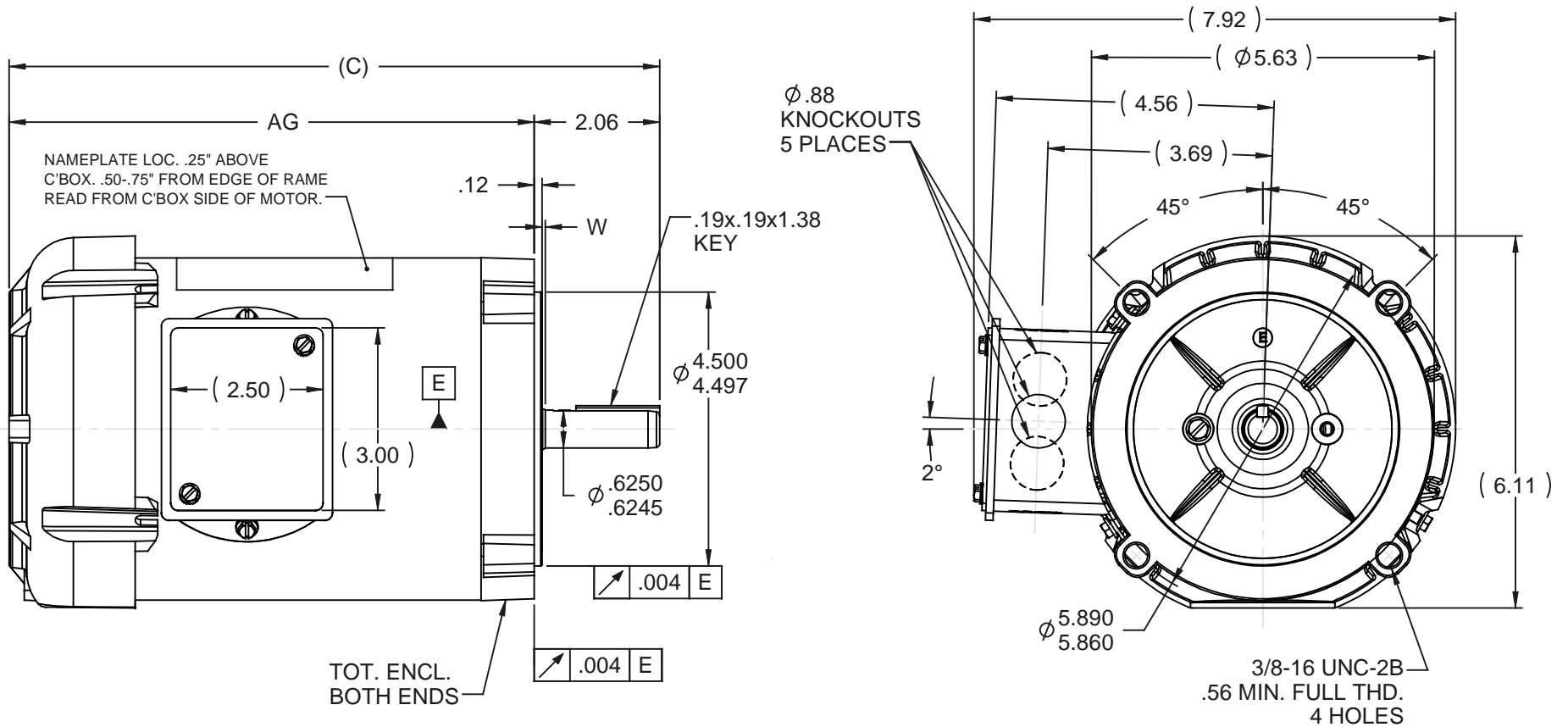

DASH	C	AG	REMARKS
500	9.94	7.88	
525	10.19	8.13	
575	10.69	8.63	
625	10.94	9.13	

6	UPDATED DRAWING	08-0399	RJW 03-18-2008	ML	TOLERANCES UNLESS SPECIFIED			DRAWN	RM 09-20-1991		
5	REDRAWN ON SOLIDWORKS		DRS 05-16-2005	ML	DEC	INCHES		CHK	ML 09-23-1991		
4	REV. NAMEPLATE LOC. .50-.75 WAS .25	CN 23975-129/133	MJD 09-02-1997		.X	±.1	APPR	GK 09-23-1991			
3	ADDED AG DIMENSION		RM 10-12-1992	ML	.XX	±.03	SCALE 3:8				
2	REVISED NAMEPLATE LOCATION		RM 10-07-1991	ML	.XXX	±.005	REF				
1	NEW DRAWING	3842364	RM 09-23-1991		.XXXX	±.0005	MAT'L	FMF			
NO	REVISION		BY & DATE	CHK	ANG	±1/2°	FINISH	PREV			
THIS DRAWING IN DESIGN AND DETAIL IS OUR PROPERTY AND MUST NOT BE USED EXCEPT IN CONNECTION WITH OUR WORK. ALL RIGHTS OF DESIGN AND INVENTION ARE RESERVED. THIS IS AN ELECTRONICALLY GENERATED DOCUMENT - DO NOT SCALE THIS PRINT							RFP	CAD FILE SS75175			
							DIST	WP	SIZE	DRAWING NO	REV
									<b>A</b>	<b>SS75175</b>	<b>6</b>