

SHEET 1  
 REV 9  
 SIZE 52A101925  
 DRAWING NO. A

THIRD ANGLE PROJECTION

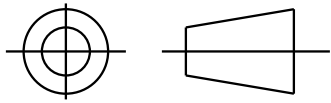

REVISIONS

| REV. | DESCRIPTION                     | DATE     | APPROVED  |
|------|---------------------------------|----------|-----------|
| 8    | REDRAWN NO CHANGE T196-22390    | 07/10/96 | MDP       |
| 9    | CHG TO RBC FORMAT PER ISO5-1777 | 12/16/05 | PRAVEEN.K |

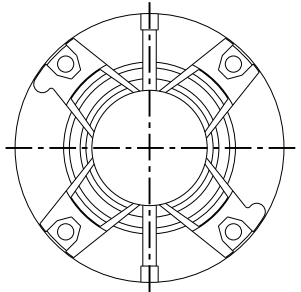

VIEW SHOWING  
PE VENTILATION  
OPENINGS

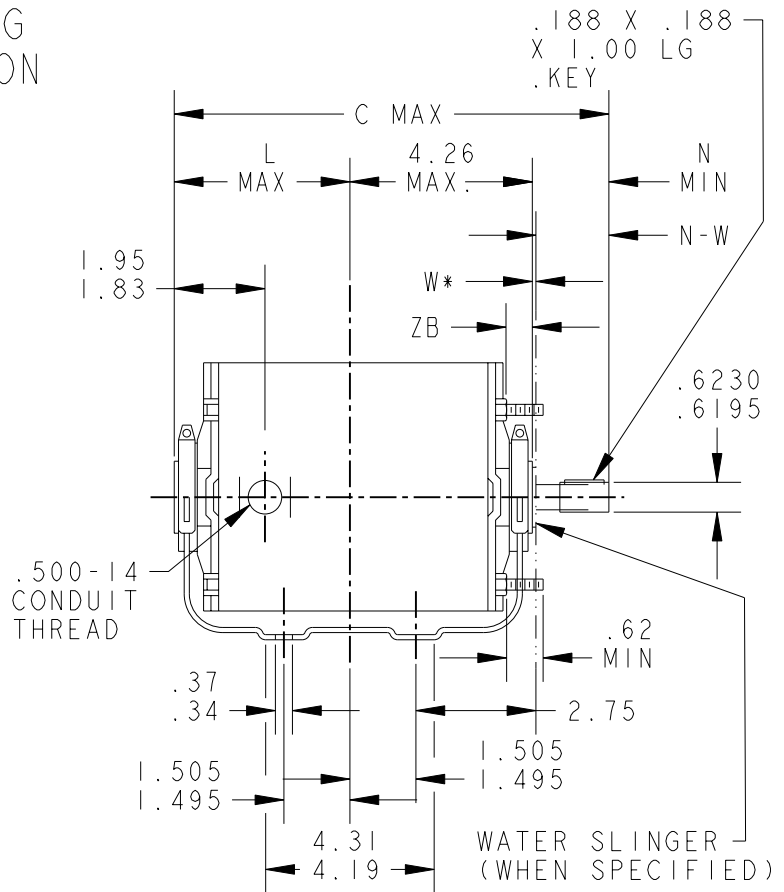
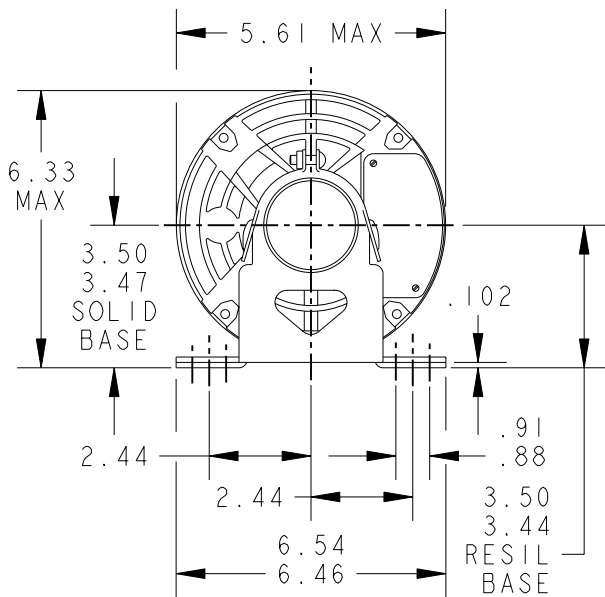

\*W IS A CLEARANCE DUE TO VARIATION IN PARTS & ASSEMBLY.

| 3  | KH   | 33      | 56Z     | 9.88  | 1.16 | 4.42 | 1.50 | 1.63/1.41 | .55/.52 |  |
|----|------|---------|---------|-------|------|------|------|-----------|---------|--|
| 2  | KH   | 36      | 56Z     | 10.69 | 1.91 | 4.23 | 2.25 | 2.38/2.16 | .55/.52 |  |
| 1  | KH   | 35      | 56Z     | 10.26 | 1.91 | 3.80 | 2.25 | 2.38/2.16 | .55/.52 |  |
| PT | TYPE | GE SIZE | NEMA FR | C     | K    | L    | N    | N-W       | ZB      |  |

|                               |  |                        |  |              |   |              |  |                  |  |              |
|-------------------------------|--|------------------------|--|--------------|---|--------------|--|------------------|--|--------------|
| SIGNATURES                    |  | DATE                   |  |              | REGAL-BELOIT CORPORATION  |              |  |                  |  |              |
| MODEL                         |  | JPK 02/17/76           |  |              | <b>TITLE</b><br><b>OUTLINE</b><br><b>FORM N-GENERAL PURPOSE MOTOR-DRIP PROOF-SOLID</b><br><b>OR RESIL BASE-BALL OR SLEEVE BEARING. FMF 5KH35JN30X</b> |              |  |                  |  |              |
| DETAIL                        |  | .                      |  |              |   |              |  |                  |  |              |
| CHECKED                       |  | .                      |  |              |   |              |  |                  |  |              |
| ENGRG                         |  | .                      |  |              |   |              |  |                  |  |              |
| MFG                           |  | .                      |  | SIZE         |   | DRAWING      |  | <b>52A101925</b> |  | <b>REV 9</b> |
| FOR ADDITIONAL INFO REFER TO: |  | QUALITY                |  | A            |   | A            |  |                  |  |              |
| APPLIED PRACTICES             |  | ISSUED                 |  | MDP 07/10/96 |   | SCALE: 1.000 |  | REF. No: .       |  | SHEET 1 of 1 |
| DIMENSIONS ARE IN INCHES ✓    |  | SOLID MODEL: 52A101925 |  |              |   |              |  |                  |  |              |