

PRODUCT INFORMATION PACKET

marathon[®]
Motors

Model No: 444TSTD4332
Catalog No: U535A
150,1800,DP,444TS,3/60/460
Fire Pump

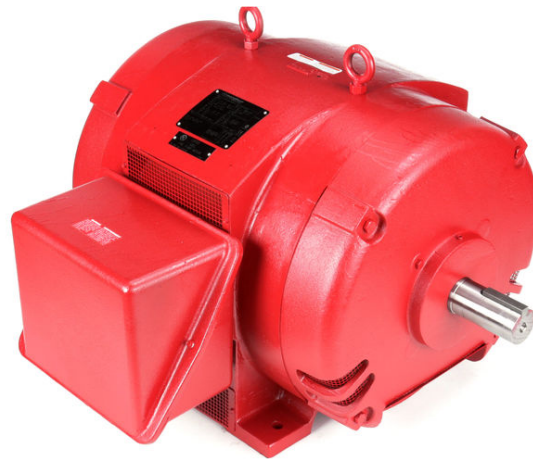

Regal and Marathon are trademarks of Regal Beloit Corporation or one of its affiliated companies.
©2019 Regal Beloit Corporation, All Rights Reserved. MC017097E

REGAL[®]



Nameplate Specifications

Output HP	150 HP	Output KW	112.0 kW
Frequency	60 Hz	Voltage	460 V
Current	170.0 A	Speed	1788 RPM
Service Factor	1.15	Phase	3
Efficiency	95 %	Duty	Continuous
Insulation Class	F	Design Code	C
KVA Code	F	Frame	444TS
Enclosure	Drip Proof	Overload Protector	No
Ambient Temperature	50 °C	Drive End Bearing Size	6319
Opp Drive End Bearing Size	6317	UL	Listed
CSA	Y	CE	Y
IP Code	23		

Technical Specifications

Electrical Type	Squirrel Cage Induction Run	Starting Method	Part Wdg Start & Wye Start Delta Run
Poles	4	Rotation	Reversible
Mounting	Rigid Base	Motor Orientation	Horizontal
Drive End Bearing	Ball	Opp Drive End Bearing	Ball
Frame Material	Cast Iron	Shaft Type	TS
Overall Length	40.83 in	Frame Length	25.98 in
Shaft Diameter	2.375 in	Shaft Extension	4.75 in
Assembly/Box Mounting	F1/F2 CAPABLE		
Outline Drawing	SS620756-444TS	Connection Diagram	EE7300BH

This is an uncontrolled document once printed or downloaded and is subject to change without notice. Date Created: 08/20/2019

SS620756

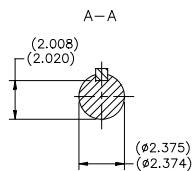
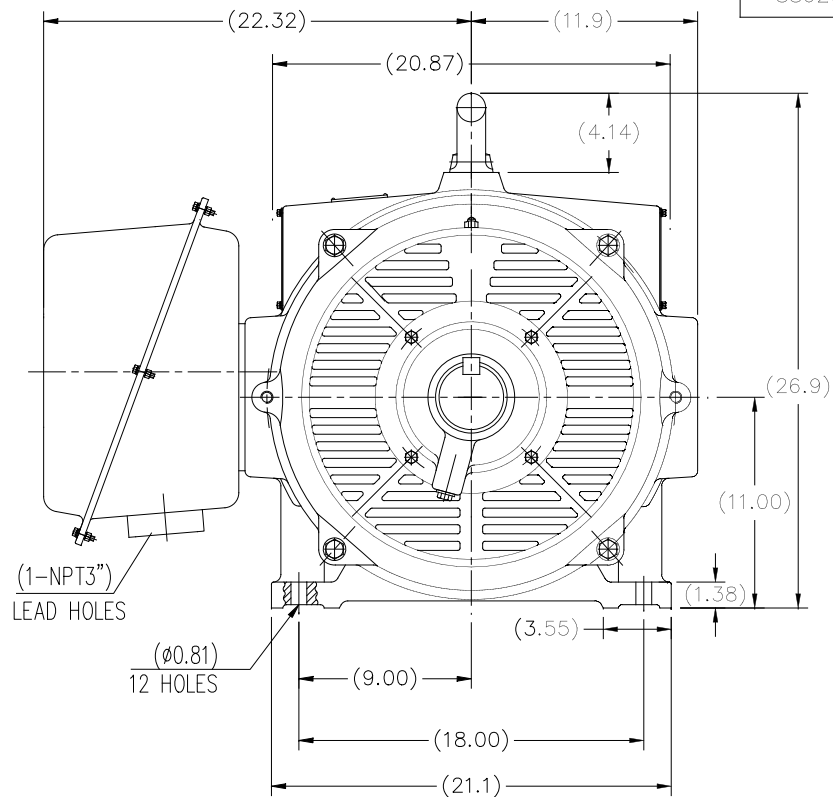
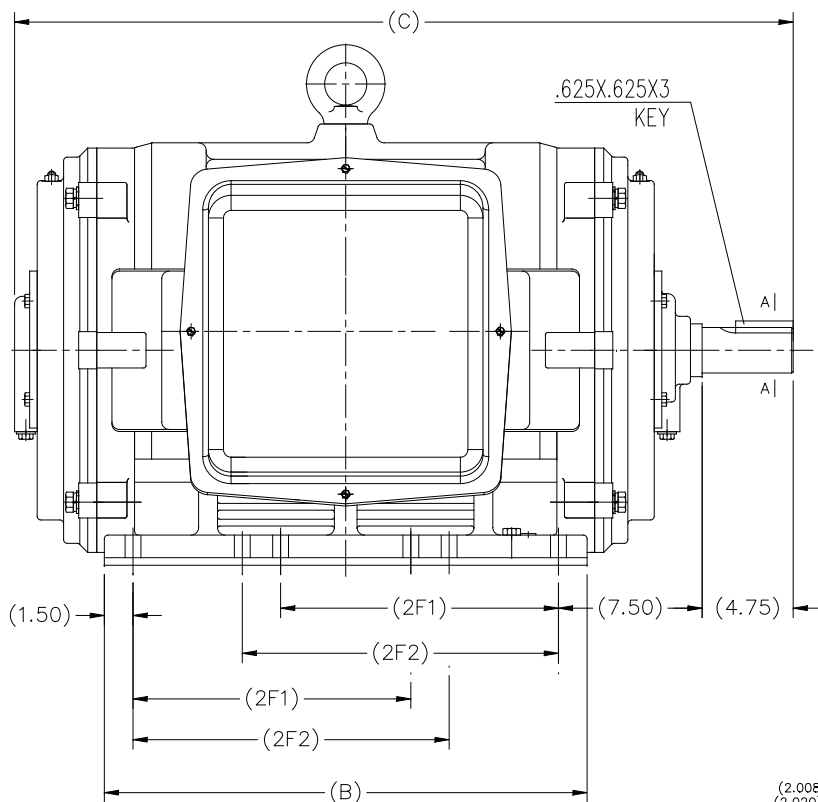

F2 MOUNTING

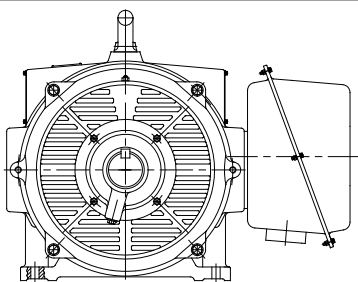

444TS	40.83	25.2	14.5	16.5
445TS				
447TS	45.95	30.31	20	25
449TS				
Frame	C	B	2F1	2F2

		TOLERANCES UNLESS SPECIFIED		DRAWN 2XW 07-21-2016	
		DEC.	INCHES	CHK	
		.X	±.1	APPD	
		.XX	±.03	SCALE NONE	
		.XXX	±.005	REF	
		.XXXX	±.0005	FINISH	
NO. REVISION		BY & DATE	CHK	FINISH	
THIS DRAWING IN DESIGN AND DETAIL IS OUR PROPERTY AND MUST NOT BE USED EXCEPT IN CONNECTION WITH OUR WORK ALL RIGHTS OF DESIGN AND INVENTION ARE RESERVED THIS IS AN ELECTRONICALLY GENERATED DOCUMENT - DO NOT SCALE THIS PRINT		RFP	ANG	CAD FILE SS620756	
		DIST		SIZE B	DRAWING NO. SS620756
				PAGE 1 OF 1	REV.
					SS620756





VIEW OF TERMINAL END

				TOLERANCES UNLESS SPECIFIED		REGAL REGAL - BELOIT CORPORATION	DRAWN RJW 02-11-2005			
				DEC.	INCHES		CHK	ML	02-11-2005	
				.X	±.1		APPD	GK	02-11-2005	
				.XX	±.02	TITLE CONNECTION DIAGRAM		SCALE		
D	CHANGED TO REGAL TITLE BLOCK	ECO-0108299	WGJ 08/22/2016	EMH	.XXX ±.005	12 LEAD- SINGLE VOLTAGE		REF		
1	ADDED IEC TERMINAL MARKINGS	CN 41429	JJB 05/24/2007	ML	.XXXX ±.0005	MAT'L.		FMF		
NO.	REVISION	BY & DATE	CHK	ANG	±7'30"	FINISH		PREV		
THIS DRAWING IN DESIGN AND DETAIL IS OUR PROPERTY AND MUST NOT BE USED EXCEPT IN CONNECTION WITH OUR WORK ALL RIGHTS OF DESIGN AND INVENTION ARE RESERVED THIS IS AN ELECTRONICALLY GENERATED DOCUMENT - DO NOT SCALE THIS PRINT				RFP	02-11-2005	CAD FILE ee7300bh	SIZE	DRAWING NO.	PAGE OF	REV.
				DIST	LB		A	EE7300BH		C



P.O. BOX 8003
WAUSAU, WI 54401-8003
PH. 715-675-3311

DATA VOLTS: 460

CERTIFICATION DATA SHEET

CUSTOMER P.O. #:
 ORDER #: EE7300BH REFERENCE MODEL #: 444TSTDCC4332
 CONN. DIAGRAM: SS620756 CAT #: U535A
 OUTLINE: IE3L2804110 NONE 1 CUSTOMER PART #:
 WINDING: IE3L2804110 NONE 1 MOUNTING: F1/F2 CAPABLE
 SPEED:
 TYPICAL MOTOR PERFORMANCE DATA

HP	KW	SYNC RPM	FL RPM	FRAME	ENCLOSURE	TYPE	KVA CODE	DESIGN
150	112	1800	1788	444TS	DP	TDC	F	B

PH	HZ	VOLTS	AMPS	START TYPE	DUTY	INSL	S.F.	AMB	ELEV.
3	60/50	460#380	170&172	PWS & YDRUN	CONT	F	1.15	50	3300
	F.L. EFF	95.0	3/4 LD EFF	95.0	1/2 LD EFF	94.5	GTD EFF	ELECT. TYPE	
	F.L. PF	87.0	3/4 LD PF	85.0	1/2 LD PF	80.0	94.1	SQ CAGE IND RUN	

F.L. TORQUE	LR AMPS @ 460 V	L.R. TORQUE	B.D. TORQUE	F.L. RISE (°C)
441 LB-FT	995	850 LB-FT	925 LB-FT	210%
@ 3 FT.	POWER	ROTOR WK ²	MAX. LOAD WK ²	SAFE STALL TIME
85 DBA	94 DBA	95.0 LB-FT ²	0 LB-FT ²	0 SEC.
				START/SHOUR
				MOTOR WGT
				3500 LB.

*** SUPPLEMENTAL INFORMATION ***

DE BRACKET TYPE	ODE BRACKET TYPE	MOUNT TYPE	MOTOR ORIENTATION	SEVERE DUTY	HAZARDOUS LOCATION	DRIP COVER	SCREENS	PAINT
STANDARD	STANDARD	RIGID	HORIZONTAL	NO	NONE	NO	NONE	RED (ENAMEL)
BEARINGS		GREASE	SHAFT TYPE	SPECIAL DE	SPECIAL ODE	SHAFT	MATERIAL	FRAME MATERIAL
DE BALL 6319	ODE BALL 6317	POLYREX EM	TS	NONE	NONE	1045 HOT ROLLED (C-204)		CAST IRON

THERMOSTATS	PROTECTORS	WDG RTD's	BRG RTD's	THERMISTORS	CONTROL	SPACE HEATERS
NONE	NOT	NONE	NONE	NONE	FALSE	NA
R1 (ohms/ph)	R2 (ohms/ph)	X1 (ohms/ph)	X2 (ohms/ph)	Xm (ohms/ph)	VIBRATION (in/sec)	FLOAT
0.026	0.011	0.127	0.233	5.661	0.150	ODE

* N		INVERTER TORQUE: NONE	
O	INV. HP SPEED RANGE: NONE		
T	ENCODER: NONE		
E	BRAKE: NONE		
S	FT-LB: NONE		
	VOLTAGE: NONE		
	HZ: NONE		

PREPARED BY: FAREEDA DUDEKULA
 DATE: 8/28/2018
 FORM: 3531 REV 4 2/27/06

Data Sheet

444TSTD4332



Submittal

Data @ 460 V

Date: 12/13/2018

Customer: _____
Attention: _____

Submitted by: FAREEDA DUDEKULA

Motor Load Data

Load	0%	25%	50%	75%	100%	115%	125%	LR
Current (Amps)	47.0	62.0	92.0	130	170	195	215	995
Torque (ft-lb)	0.00	110	220	330	441	508	552	850
RPM	1800	1796	1794	1790	1788	1784	1784	0
Efficiency (%)		91.7	94.5	95.0	95.0	95.0	94.5	
P.F. (%)	5.5	62.0	80.0	85.0	87.0	87.5	87.5	40.0

Motor Speed Data

LR	Pull-Up	BD	Rated	Idle	Information Block
Speed (RPM)	0	900	1725	1788	HP
Current (Amps)	995	750	535	170	Sync. RPM
Torque (ft-lb)	850	750	441	0.00	Frame
					Enclosure
					Construction
					Voltage
					Frequency
					Design
					LR Code letter
					Service Factor
					Temp Rise @ FL
					Duty
					Ambient
					Elevation
					Motor/Shaft Wk ²
					Ret Wdg
					Sound Pressure @ 1M
					VFD Rating
					Outline Dwg
					Conn. Diag
					Additional Specifications:

