

LOAD PERFORMANCE CURVE

Three Phase Induction Motor - Squirrel Cage



Customer : Dealers Industrial Equipment 800-469-3110
 Customer reference : 14829571

Product line : W40 JP Pump High Efficiency
 Three-Phase

Product code : 14829571

Catalog # : 06018OP3VFP364JPV-W4

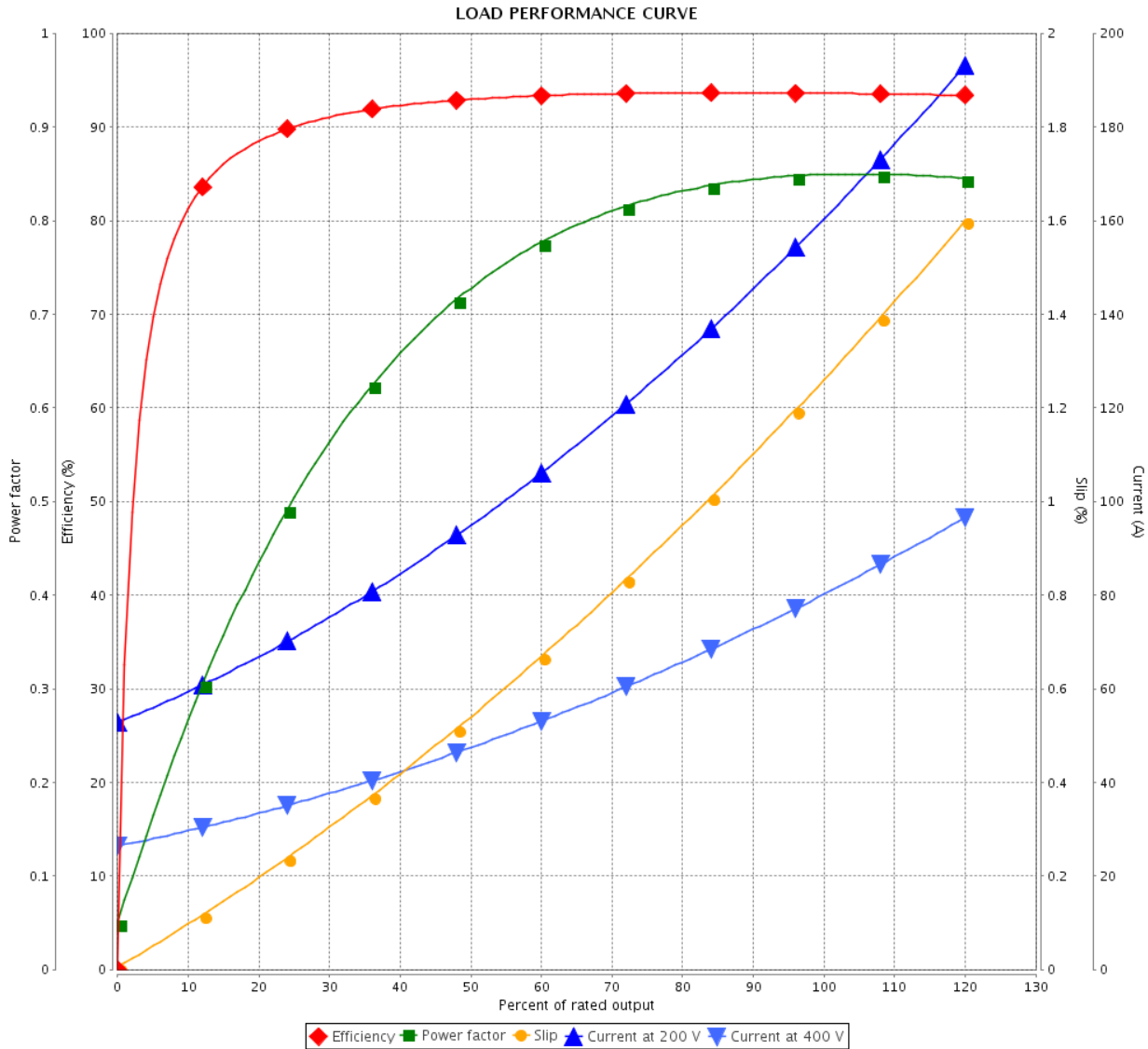

Performance : 200/400 V 60 Hz 4P

Rated current : 163/81.7 A
 LRC : 6.1
 Rated torque : 175 ft.lb
 Locked rotor torque : 180 %
 Breakdown torque : 229 %
 Rated speed : 1777 rpm

Moment of inertia (J) : 12.8 sq.ft.lb
 Duty cycle : Cont.(S1)
 Insulation class : F
 Service factor : 1.15
 Temperature rise : 80 K
 Design : B

Rev.	Changes Summary	Performed	Checked	Date
Performed by			Page	Revision
Checked by			2 / 2	
Date	16/04/2019			

Dimensões em polegada
Dimensions in inches

THIS IS AN UPDATED REVISION, THE
PREVIOUS ONE MUST BE DISREGARDED.

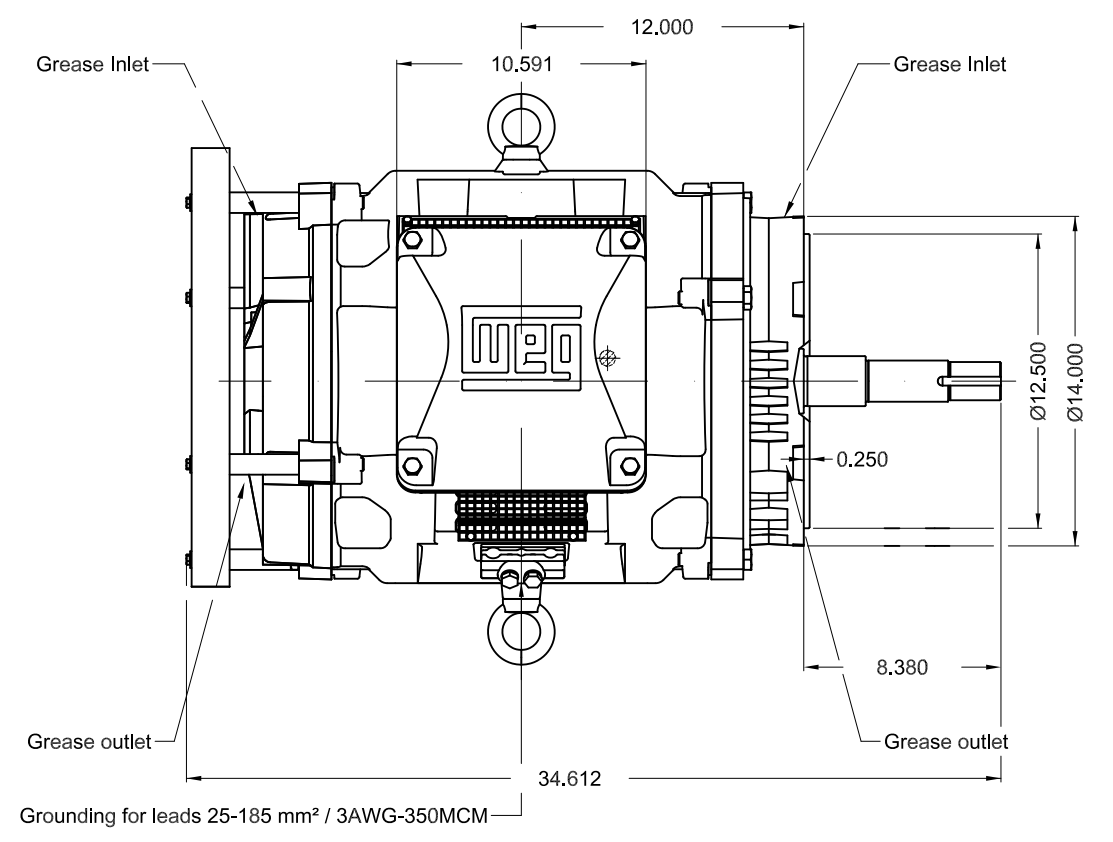
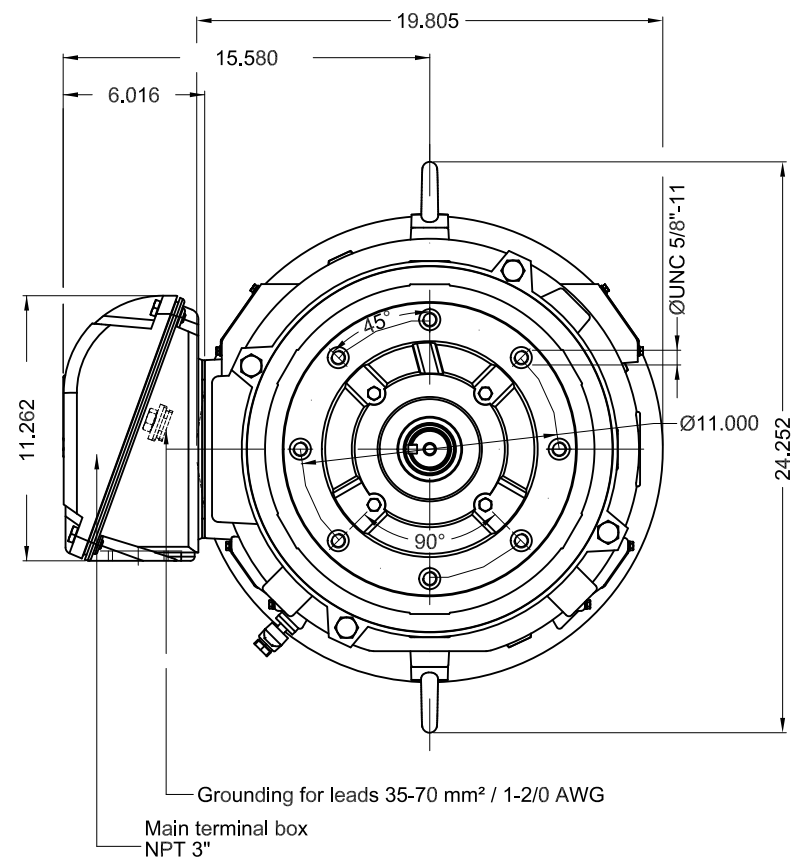

Color RAL 3002									
Painting plan 203A									
Mounting V18									
					SCALE	1:8			
ECM	LOC	SUMMARY OF MODIFICATIONS			EXECUTED	CHECKED	RELEASED	DATE	VER
EXECUTED	USERADMIN	THREE PHASE W40 MOTOR HIGH EFF							
CHECKED		FRAME 364/5JP IP23 ODP							
RELEASED		CLOSE COUPLED PUMP JP TYPE W							
REL DT	16.04.2019	WMO	Jaragua do Sul	Product Engineering	SHEET	1 / 1			

60 HP 04 Poles 60Hz

A

