

# DATA SHEET



## Three Phase Induction Motor - Squirrel Cage

Customer	: Dealers Industrial Equipment 800-469-3110				
Customer reference	: 01512OT3H284TC-W40				
Product line	: W40 NEMA Premium Efficiency Three-Phase	Product code :	14786493		
		Catalog # :	01512OT3H284TC-W40		
Frame	: 284TC	Locked rotor time	: 28s (cold) 16s (hot)		
Output	: 15 HP (11 kW)	Temperature rise	: 80 K		
Poles	: 6	Duty cycle	: Cont.(S1)		
Frequency	: 60 Hz	Ambient temperature	: -20°C to +40°C		
Rated voltage	: 575 V	Altitude	: 1000 m.a.s.l.		
Rated current	: 14.7 A	Protection degree	: IP23		
L. R. Amperes	: 92.7 A	Cooling method	: IC01 - ODP		
LRC	: 6.3x(Code G)	Mounting	: F-1		
No load current	: 6.24 A	Rotation <sup>1</sup>	: Both (CW and CCW)		
Rated speed	: 1180 rpm	Noise level <sup>2</sup>	: 59.0 dB(A)		
Slip	: 1.67 %	Starting method	: Direct On Line		
Rated torque	: 65.9 ft.lb	Approx. weight <sup>3</sup>	: 337 lb		
Locked rotor torque	: 260 %				
Breakdown torque	: 260 %				
Insulation class	: F				
Service factor	: 1.25				
Moment of inertia (J)	: 4.80 sq.ft.lb				
Design	: B				
Output	50%	75%	100%	Foundation loads	
Efficiency (%)	91.0	91.7	91.7	Max. traction	
Power Factor	0.67	0.77	0.82	Max. compression	
		<u>Drive end</u>	<u>Non drive end</u>		
Bearing type	:	6311 Z C3	6211 Z C3		
Sealing	:	Without Bearing Seal	Without Bearing Seal		
Lubrication interval	:	20000 h	20000 h		
Lubricant amount	:	18 g	11 g		
Lubricant type	:	Mobil Polyrex EM			
Notes downloaded from <a href="http://dealerselectric.com">http://dealerselectric.com</a>					
This revision replaces and cancel the previous one, which must be eliminated. (1) Looking the motor from the shaft end. (2) Measured at 1m and with tolerance of +3dB(A). (3) Approximate weight subject to changes after manufacturing process. (4) At 100% of full load.			These are average values based on tests with sinusoidal power supply, subject to the tolerances stipulated in NEMA MG-1.		
Rev.	Changes Summary		Performed	Checked	Date
Performed by					
Checked by				Page	Revision
Date	22/04/2019			1 / 2	

# LOAD PERFORMANCE CURVE



## Three Phase Induction Motor - Squirrel Cage

Customer : Dealers Industrial Equipment 800-469-3110  
 Customer reference : 01512OT3H284TC-W40

Product line : W40 NEMA Premium Efficiency Three-Phase      Product code : 14786493  
 Catalog # : 01512OT3H284TC-W40

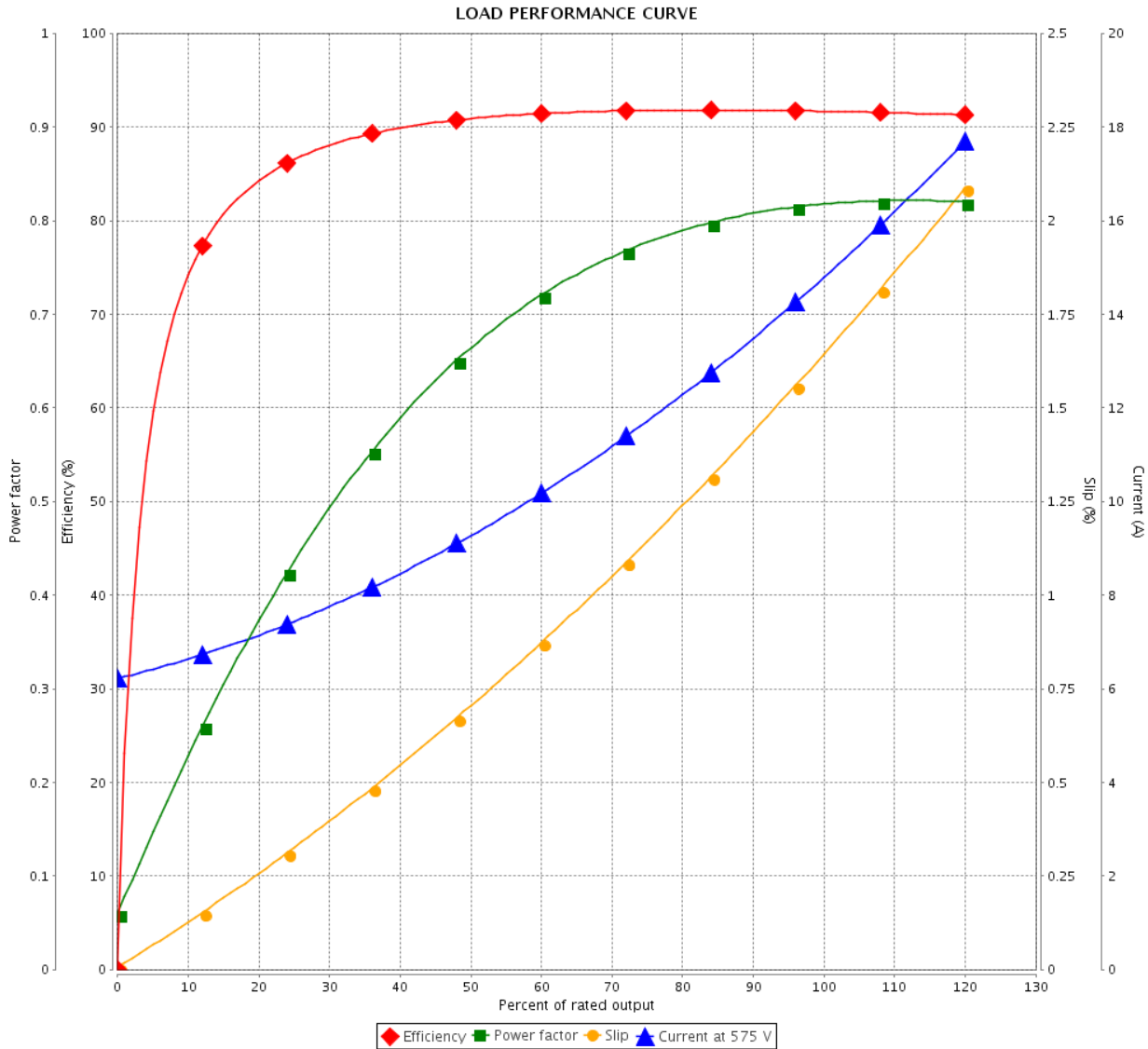

Performance : 575 V 60 Hz 6P

Rated current : 14.7 A	Moment of inertia (J) : 4.80 sq.ft.lb
LRC : 6.3	Duty cycle : Cont.(S1)
Rated torque : 65.9 ft.lb	Insulation class : F
Locked rotor torque : 260 %	Service factor : 1.25
Breakdown torque : 260 %	Temperature rise : 80 K
Rated speed : 1180 rpm	Design : B

Rev.	Changes Summary	Performed	Checked	Date
Performed by			Page 2 / 2	Revision
Checked by				
Date	22/04/2019			

Dimensões em polegada  
Dimensions in inches

THIS IS AN UPDATED REVISION, THE  
PREVIOUS ONE MUST BE DISREGARDED.

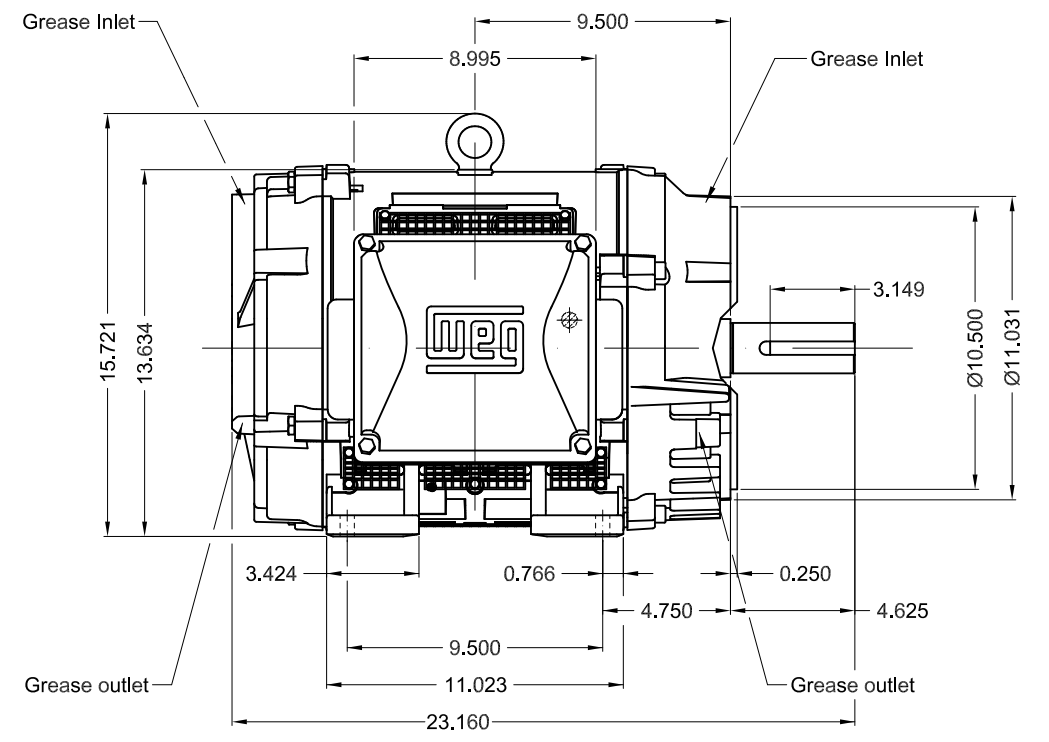
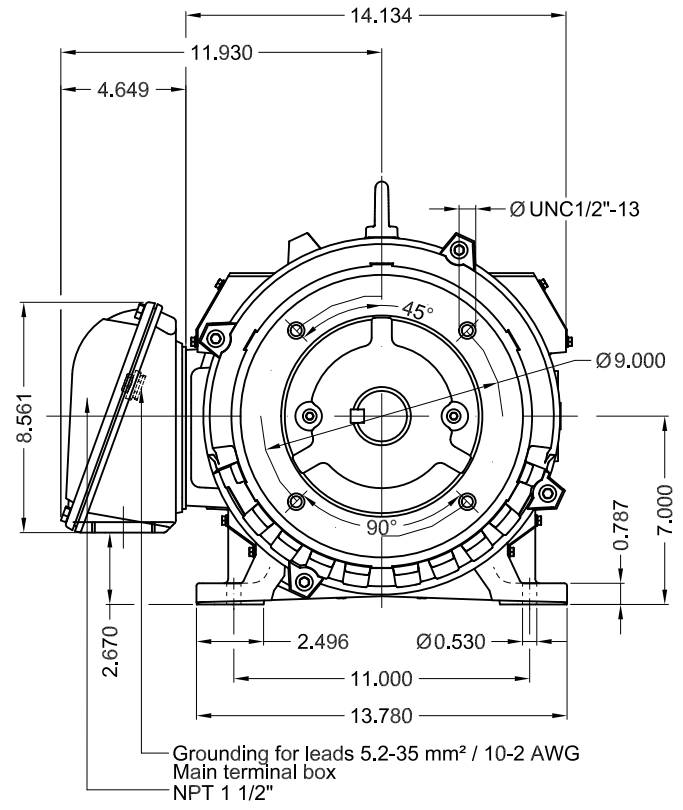

Bearing cap									
Color RAL 5009									
Painting plan 203A									
Mounting B34R(D)									
						SCALE	1:7		
ECM	LOC	SUMMARY OF MODIFICATIONS			EXECUTED	CHECKED	RELEASED	DATE	VER
EXECUTED	USERADMIN	THREE PHASE W40 MOTOR NEMA PREMIUM EFF							
CHECKED		FRAME 284TC IP23 ODP							
RELEASED		WEG code: 14786493							
REL DT	22.04.2019	WMO	Jaragua do Sul	Product Engineering	SHEET	1 / 1			

15 HP 06 Poles 60Hz

A