

DATA SHEET



Three Phase Induction Motor - Squirrel Cage

Customer : Dealers Industrial Equipment 800-469-3110
 Customer reference : 04018OT3H324T-W40G

Product line : W40 NEMA Premium Efficiency Three-Phase Product code : 14503953
 Catalog # : 04018OT3H324T-W40G

Frame : 324T	Locked rotor time : 23s (cold) 13s (hot)
Output : 40 HP (30 kW)	Temperature rise : 80 K
Poles : 4	Duty cycle : Cont.(S1)
Frequency : 60 Hz	Ambient temperature : -20°C to +40°C
Rated voltage : 575 V	Altitude : 1000 m.a.s.l.
Rated current : 38.1 A	Protection degree : IP23
L. R. Amperes : 236 A	Cooling method : IC01 - ODP
LRC : 6.2x(Code G)	Mounting : F-1
No load current : 14.8 A	Rotation ¹ : Both (CW and CCW)
Rated speed : 1775 rpm	Noise level ² : 66.0 dB(A)
Slip : 1.39 %	Starting method : Direct On Line
Rated torque : 117 ft.lb	Approx. weight ³ : 472 lb
Locked rotor torque : 200 %	
Breakdown torque : 240 %	
Insulation class : F	
Service factor : 1.25	
Moment of inertia (J) : 5.69 sq.ft.lb	
Design : B	

Output	25%	50%	75%	100%	Foundation loads
Efficiency (%)	93.5	93.6	94.1	94.1	Max. traction
Power Factor	0.44	0.70	0.80	0.84	Max. compression

	<u>Drive end</u>	<u>Non drive end</u>
Bearing type :	6312 Z C3	6211 Z C3
Sealing :	Without Bearing Seal	Without Bearing Seal
Lubrication interval :	20000 h	20000 h
Lubricant amount :	21 g	11 g
Lubricant type :	Mobil Polyrex EM	

Notes
 downloaded from <http://dealerselectric.com>

This revision replaces and cancel the previous one, which must be eliminated.
 (1) Looking the motor from the shaft end.
 (2) Measured at 1m and with tolerance of +3dB(A).
 (3) Approximate weight subject to changes after manufacturing process.
 (4) At 100% of full load.

These are average values based on tests with sinusoidal power supply, subject to the tolerances stipulated in NEMA MG-1.

Rev.	Changes Summary	Performed	Checked	Date
Performed by				
Checked by			Page	Revision
Date	14/04/2019		1 / 2	

LOAD PERFORMANCE CURVE



Three Phase Induction Motor - Squirrel Cage

Customer : Dealers Industrial Equipment 800-469-3110
 Customer reference : 04018OT3H324T-W40G

Product line : W40 NEMA Premium Efficiency Three-Phase Product code : 14503953
 Catalog # : 04018OT3H324T-W40G

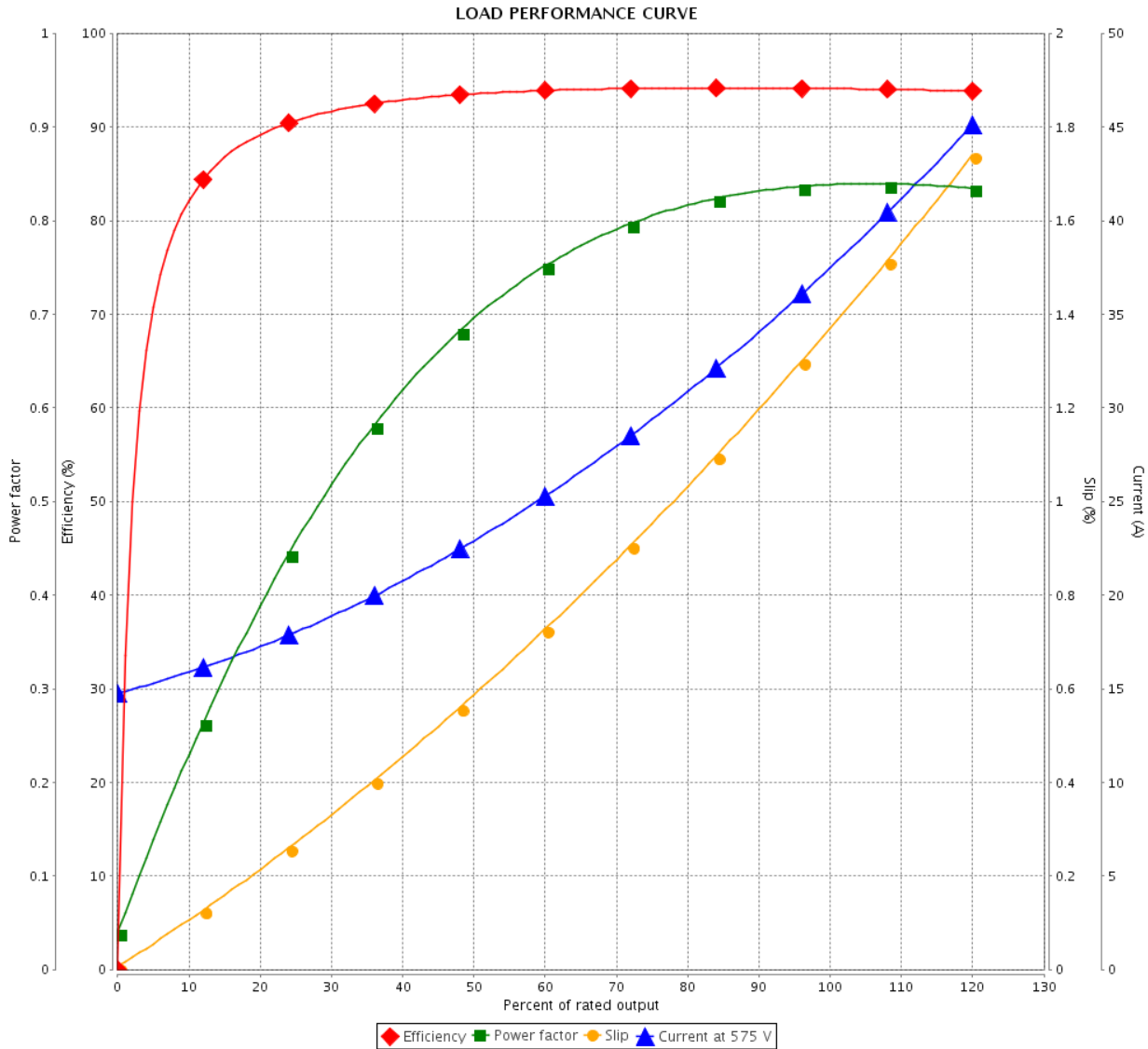

Performance : 575 V 60 Hz 4P

Rated current : 38.1 A	Moment of inertia (J) : 5.69 sq.ft.lb
LRC : 6.2	Duty cycle : Cont.(S1)
Rated torque : 117 ft.lb	Insulation class : F
Locked rotor torque : 200 %	Service factor : 1.25
Breakdown torque : 240 %	Temperature rise : 80 K
Rated speed : 1775 rpm	Design : B

Rev.	Changes Summary	Performed	Checked	Date
Performed by			Page	Revision
Checked by			2 / 2	
Date	14/04/2019			

Dimensões em polegada
Dimensions in inches

THIS IS AN UPDATED REVISION, THE
PREVIOUS ONE MUST BE DISREGARDED.

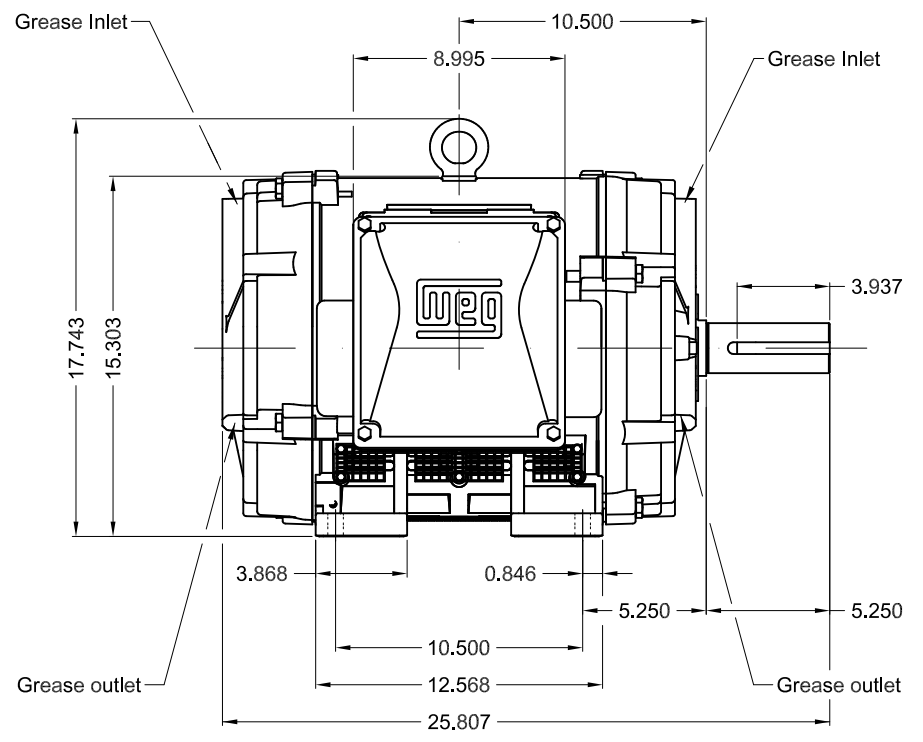
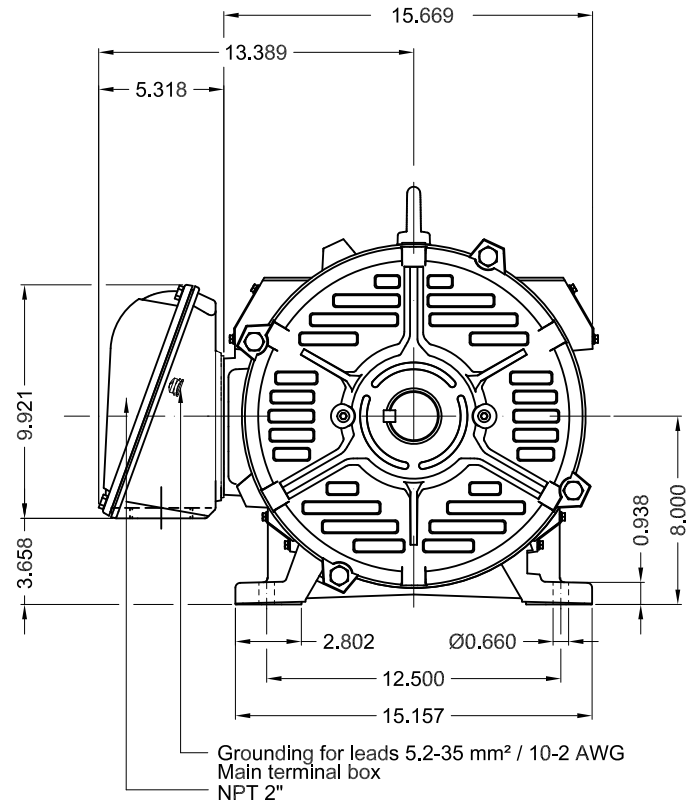

Internal AEGIS ground ring on the DE									
Color RAL 5009									
Painting plan 203A									
Mounting B3R(D)									
					SCALE	1:8			
ECM	LOC	SUMMARY OF MODIFICATIONS			EXECUTED	CHECKED	RELEASED	DATE	VER
EXECUTED	USERADMIN	THREE PHASE W40 MOTOR NEMA PREMIUM EFF							
CHECKED		FRAME 324T IP23 ODP							
RELEASED		WEG code: 14503953							
REL DT	14.04.2019	WMO	Jaragua do Sul	Product Engineering	SHEET	1 / 1			

40 HP 04 Poles 60Hz

A



ZME A3