

DATA SHEET



Three Phase Induction Motor - Squirrel Cage

Customer : Dealers Industrial Equipment 800-469-3110
 Customer reference : 03018OT3P286T-W40

Product line : W40 NEMA Premium Efficiency Three-Phase Product code : 14501153
 Catalog # : 03018OT3P286T-W40

Frame : 284/6T	Locked rotor time : 32s (cold) 18s (hot)
Output : 30 HP (22 kW)	Temperature rise : 80 K
Poles : 4	Duty cycle : Cont.(S1)
Frequency : 60 Hz	Ambient temperature : -20°C to +40°C
Rated voltage : 200 V	Altitude : 1000 m.a.s.l.
Rated current : 80.3 A	Protection degree : IP23
L. R. Amperes : 530 A	Cooling method : IC01 - ODP
LRC : 6.6x(Code G)	Mounting : F-1
No load current : 33.3 A	Rotation ¹ : Both (CW and CCW)
Rated speed : 1770 rpm	Noise level ² : 64.0 dB(A)
Slip : 1.67 %	Starting method : Direct On Line
Rated torque : 87.8 ft.lb	Approx. weight ³ : 398 lb
Locked rotor torque : 280 %	
Breakdown torque : 280 %	
Insulation class : F	
Service factor : 1.25	
Moment of inertia (J) : 4.52 sq.ft.lb	
Design : B	

Output	25%	50%	75%	100%	Foundation loads
Efficiency (%)	93.4	93.6	94.1	94.1	Max. traction
Power Factor	0.44	0.70	0.80	0.84	Max. compression

	<u>Drive end</u>	<u>Non drive end</u>
Bearing type :	6311 Z C3	6211 Z C3
Sealing :	Without Bearing Seal	Without Bearing Seal
Lubrication interval :	20000 h	20000 h
Lubricant amount :	18 g	11 g
Lubricant type :	Mobil Polyrex EM	

Notes
 downloaded from <http://dealerselectric.com>

This revision replaces and cancel the previous one, which must be eliminated.
 (1) Looking the motor from the shaft end.
 (2) Measured at 1m and with tolerance of +3dB(A).
 (3) Approximate weight subject to changes after manufacturing process.
 (4) At 100% of full load.

These are average values based on tests with sinusoidal power supply, subject to the tolerances stipulated in NEMA MG-1.

Rev.	Changes Summary	Performed	Checked	Date
Performed by		Page		Revision
Checked by		1 / 2		
Date	14/04/2019			

LOAD PERFORMANCE CURVE



Three Phase Induction Motor - Squirrel Cage

Customer : Dealers Industrial Equipment 800-469-3110
 Customer reference : 03018OT3P286T-W40

Product line : W40 NEMA Premium Efficiency Three-Phase Product code : 14501153
 Catalog # : 03018OT3P286T-W40

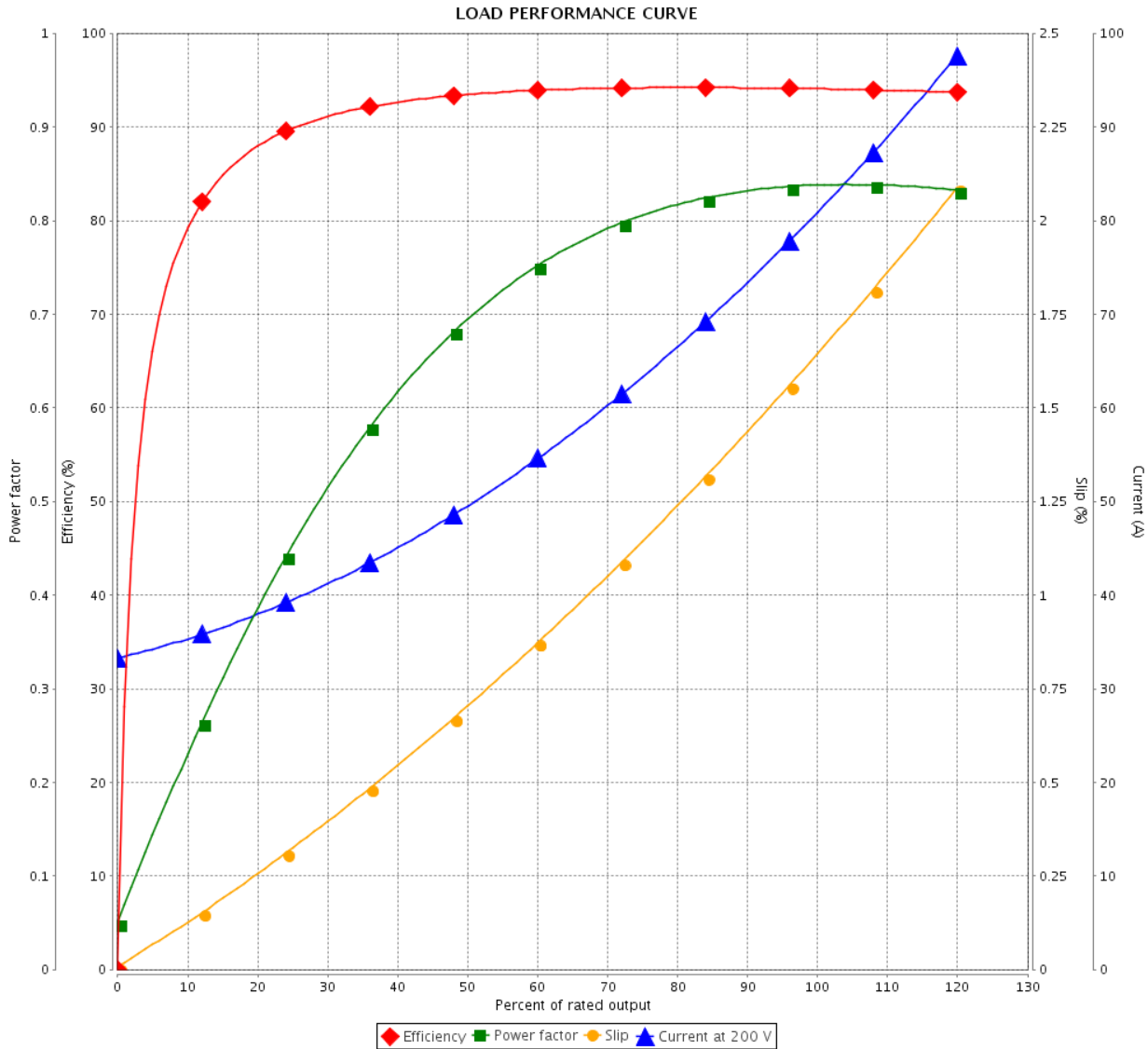

Performance : 200 V 60 Hz 4P

Rated current	: 80.3 A	Moment of inertia (J)	: 4.52 sq.ft.lb
LRC	: 6.6	Duty cycle	: Cont.(S1)
Rated torque	: 87.8 ft.lb	Insulation class	: F
Locked rotor torque	: 280 %	Service factor	: 1.25
Breakdown torque	: 280 %	Temperature rise	: 80 K
Rated speed	: 1770 rpm	Design	: B

Rev.	Changes Summary	Performed	Checked	Date
Performed by			Page	Revision
Checked by			2 / 2	
Date	14/04/2019			

Dimensões em polegada
Dimensions in inches

THIS IS AN UPDATED REVISION, THE
PREVIOUS ONE MUST BE DISREGARDED.

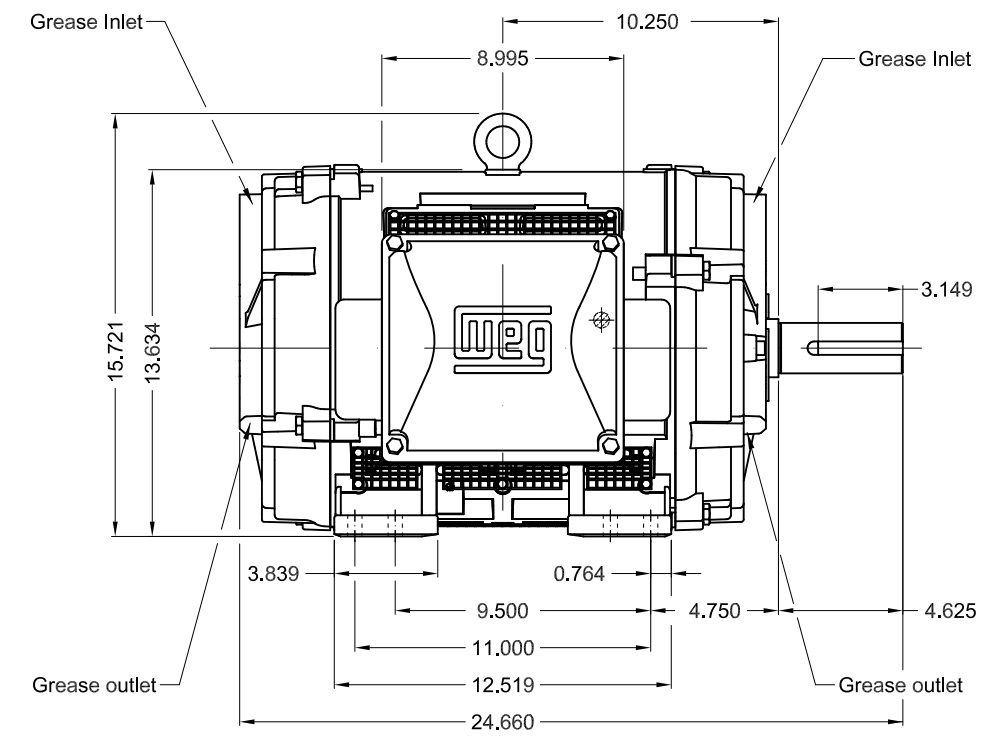
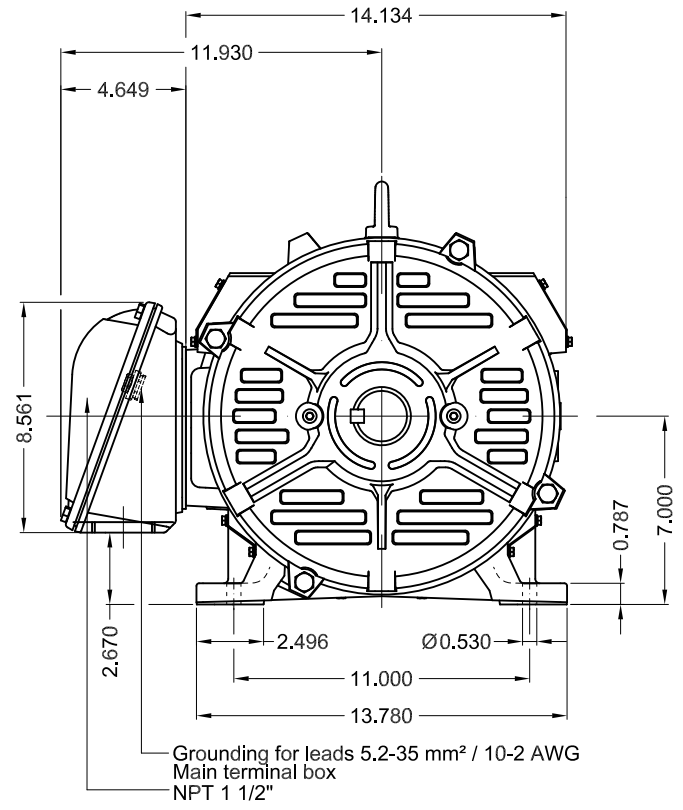

Color RAL 5009
Painting plan 203A
Mounting B3R(D)

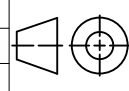
					SCALE	1:7		
ECM	LOC	SUMMARY OF MODIFICATIONS		EXECUTED	CHECKED	RELEASED	DATE	VER
EXECUTED	USERADMIN		THREE PHASE W40 MOTOR NEMA PREMIUM EFF					
CHECKED			FRAME 284/6T IP23 ODP					
RELEASED			WEG code: 14501153					
REL DT	14.04.2019	WMO	Jaragua do Sul	Product Engineering	SHEET	1 / 1		

30 HP 04 Poles 60Hz

A



ZME A3

MODEL 030180T3P286T-W40
MADE IN BRAZIL
14501153

WEG **W40 NEMA**
CC029A Premium
Inverter Duty Motor



IEC 60034-1



For use on PWM, VT 1000:1, CT 3:1, 1.0SF

PH 3	FR 284/6T	HP(kW) 30(22)	Hz 60
V 200	A 80.3	IP23	
NEMA NOM EFF	94.1 %	RPM 1770	
ENCL ODP	DUTY CONT.	INS. CL. F Δ T 80 K	
PF 0.84	DES B	CODE G	AMB. 40°C
SF 1.25	SFA 100	ALT 1000 m.a.s.l.	

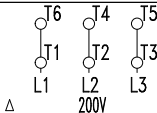

→ 6311-Z-C3
→ 6211-Z-C3

MOBIL POLYREX EM
18 g 20000 h

397 Lbs