

LOAD PERFORMANCE CURVE



Three Phase Induction Motor - Squirrel Cage

Customer : Dealers Industrial Equipment 800-469-3110
 Customer reference : 01518OT3P254T-W40

Product line : W40 NEMA Premium Efficiency Three-Phase Product code : 14500596
 Catalog # : 01518OT3P254T-W40

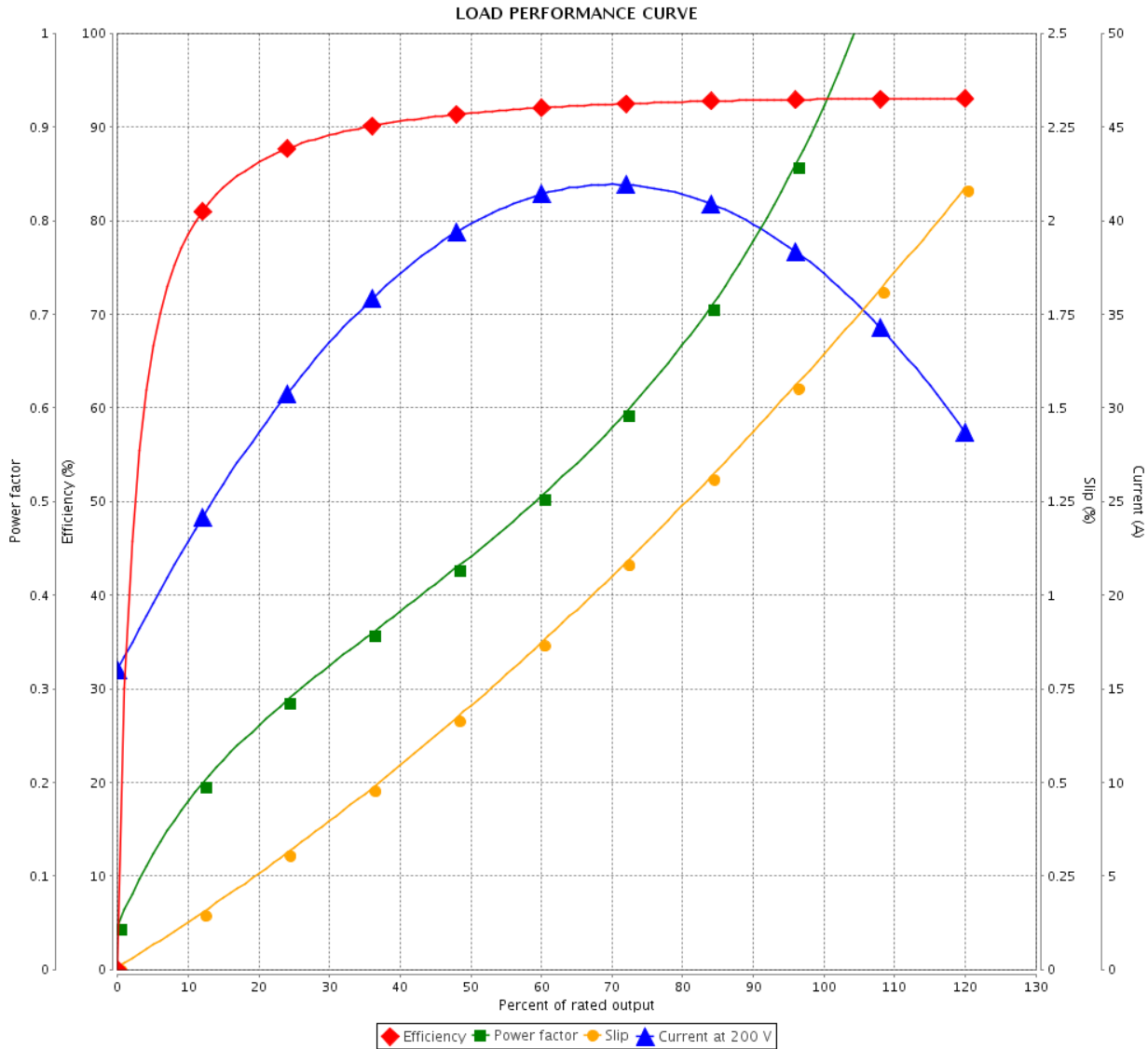

Performance : 200 V 60 Hz 4P

Rated current : 40.2 A	Moment of inertia (J) : 2.72 sq.ft.lb
LRC : 6.4	Duty cycle : Cont.(S1)
Rated torque : 43.9 ft.lb	Insulation class : F
Locked rotor torque : 240 %	Service factor : 1.25
Breakdown torque : 280 %	Temperature rise : 80 K
Rated speed : 1770 rpm	Design : B

Rev.	Changes Summary	Performed	Checked	Date
Performed by			Page 2 / 2	Revision
Checked by				
Date	13/04/2019			

Dimensões em polegada
Dimensions in inches

THIS IS AN UPDATED REVISION, THE
PREVIOUS ONE MUST BE DISREGARDED.

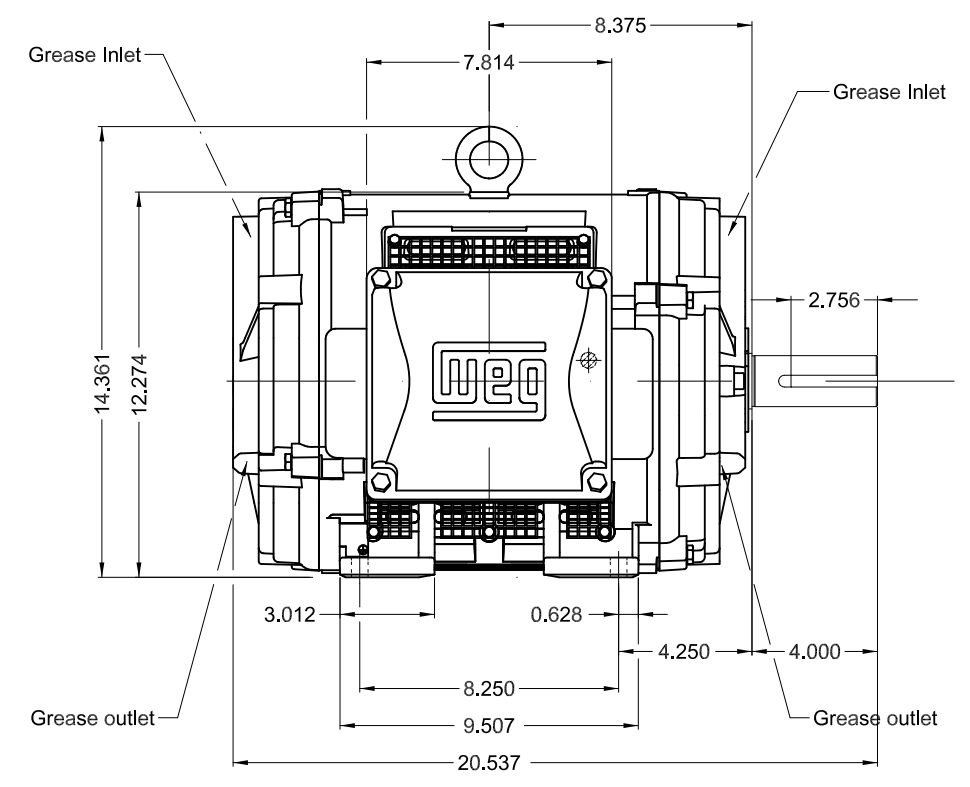
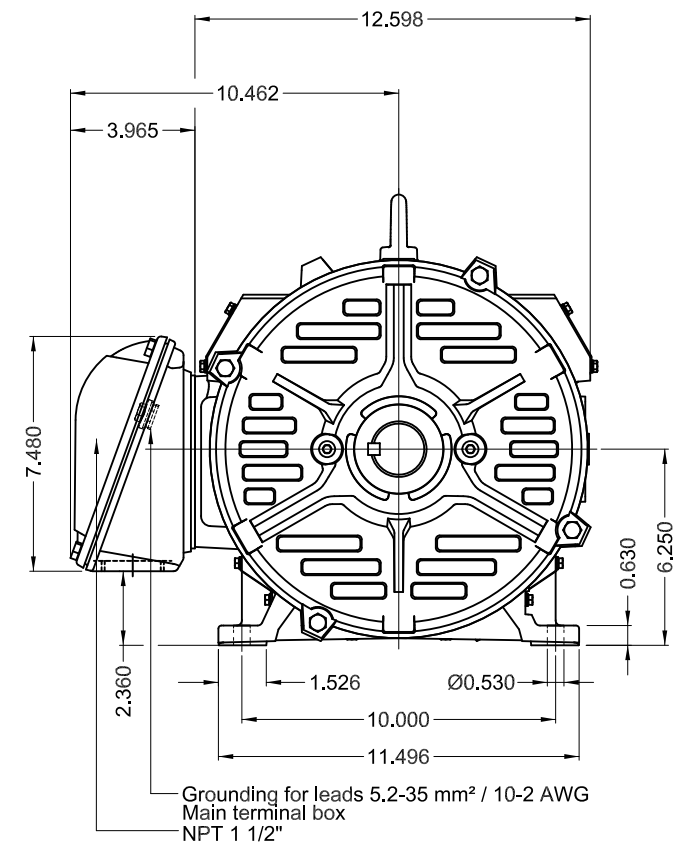

Color RAL 5009						
Painting plan 203A						
Mounting B3R(D)						
					SCALE	1:6
ECM	LOC	SUMMARY OF MODIFICATIONS		EXECUTED	CHECKED	RELEASED
EXECUTED	USERADMIN	THREE PHASE W40 MOTOR NEMA PREMIUM EFF				
CHECKED		FRAME 254T IP23 ODP				
RELEASED		WEG code: 14500596				
REL DT	13.04.2019	WMO	Jaragua do Sul	Product Engineering	SHEET	1 / 1

15 HP 04 Poles 60Hz

A

