

DATA SHEET



Three Phase Induction Motor - Squirrel Cage

Customer : Dealers Industrial Equipment 800-469-3110
 Customer reference : 02536OT3H256T-W40

Product line : W40 NEMA Premium Efficiency Three-Phase Product code : 14495228
 Catalog # : 02536OT3H256T-W40

Frame : 254/6T	Locked rotor time : 19s (cold) 11s (hot)
Output : 25 HP (18.5 kW)	Temperature rise : 80 K
Poles : 2	Duty cycle : Cont.(S1)
Frequency : 60 Hz	Ambient temperature : -20°C to +40°C
Rated voltage : 575 V	Altitude : 1000 m.a.s.l.
Rated current : 23.0 A	Protection degree : IP23
L. R. Amperes : 150 A	Cooling method : IC01 - ODP
LRC : 6.5x(Code G)	Mounting : F-1
No load current : 6.80 A	Rotation ¹ : Both (CW and CCW)
Rated speed : 3535 rpm	Starting method : Direct On Line
Slip : 1.81 %	Approx. weight ³ : 236 lb
Rated torque : 36.6 ft.lb	
Locked rotor torque : 200 %	
Breakdown torque : 280 %	
Insulation class : F	
Service factor : 1.25	
Moment of inertia (J) : 1.13 sq.ft.lb	
Design : B	

Output	25%	50%	75%	100%	Foundation loads
Efficiency (%)	90.8	91.0	91.7	91.7	Max. traction
Power Factor	0.53	0.77	0.85	0.88	Max. compression

	<u>Drive end</u>	<u>Non drive end</u>
Bearing type :	6309 Z C3	6209 Z C3
Sealing :	Without Bearing Seal	Without Bearing Seal
Lubrication interval :	20000 h	20000 h
Lubricant amount :	13 g	9 g
Lubricant type :	Mobil Polyrex EM	

Notes
 downloaded from <http://dealerselectric.com>

This revision replaces and cancel the previous one, which must be eliminated.
 (1) Looking the motor from the shaft end.
 (2) Measured at 1m and with tolerance of +3dB(A).
 (3) Approximate weight subject to changes after manufacturing process.
 (4) At 100% of full load.

These are average values based on tests with sinusoidal power supply, subject to the tolerances stipulated in NEMA MG-1.

Rev.	Changes Summary	Performed	Checked	Date
Performed by		Page		Revision
Checked by		1 / 2		
Date	14/04/2019			

LOAD PERFORMANCE CURVE



Three Phase Induction Motor - Squirrel Cage

Customer : Dealers Industrial Equipment 800-469-3110
 Customer reference : 02536OT3H256T-W40

Product line : W40 NEMA Premium Efficiency Three-Phase Product code : 14495228
 Catalog # : 02536OT3H256T-W40

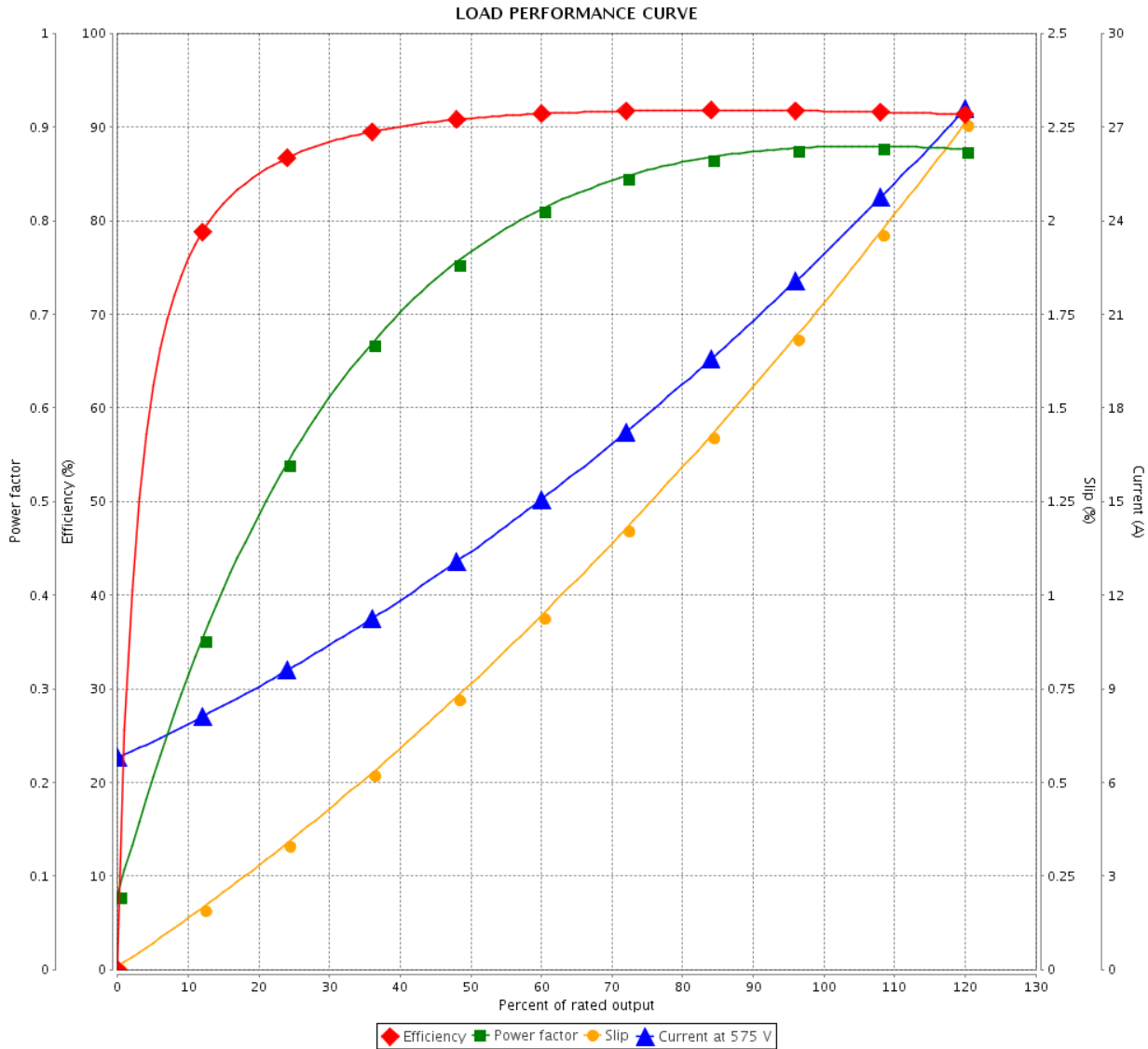

Performance : 575 V 60 Hz 2P

Rated current : 23.0 A	Moment of inertia (J) : 1.13 sq.ft.lb
LRC : 6.5	Duty cycle : Cont.(S1)
Rated torque : 36.6 ft.lb	Insulation class : F
Locked rotor torque : 200 %	Service factor : 1.25
Breakdown torque : 280 %	Temperature rise : 80 K
Rated speed : 3535 rpm	Design : B

Rev.	Changes Summary	Performed	Checked	Date
Performed by			Page 2 / 2	Revision
Checked by				
Date	14/04/2019			

Dimensões em polegada
Dimensions in inches

THIS IS AN UPDATED REVISION, THE
PREVIOUS ONE MUST BE DISREGARDED.

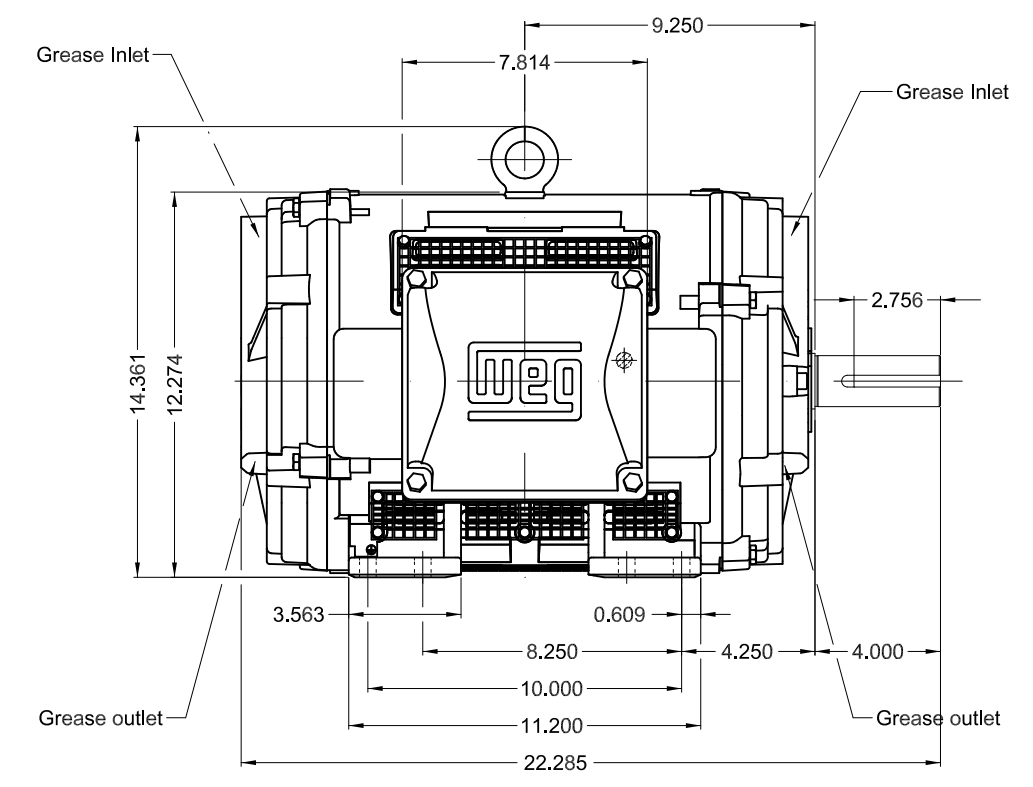
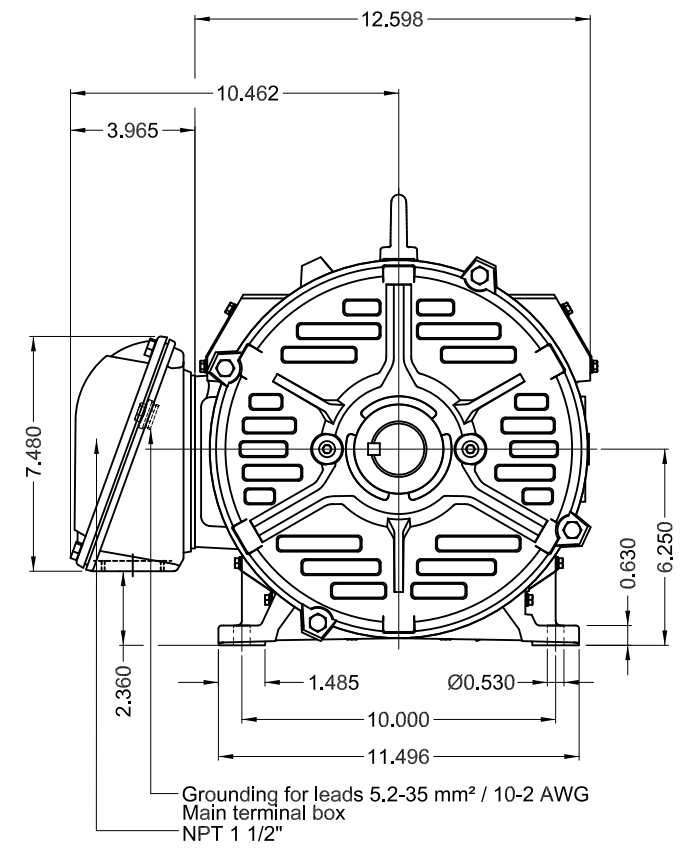

Color RAL 5009									
Painting plan 203A									
Mounting B3R(D)									
					SCALE	1:6			
ECM	LOC	SUMMARY OF MODIFICATIONS			EXECUTED	CHECKED	RELEASED	DATE	VER
EXECUTED	USERADMIN	THREE PHASE W40 MOTOR NEMA PREMIUM EFF							
CHECKED		FRAME 254/6T IP23 ODP							
RELEASED		WEG code: 14495228							
REL DT	14.04.2019	WMO	Jaragua do Sul	Product Engineering	SHEET	1 / 1			

25 HP 02 Poles 60Hz

A

