

# DATA SHEET



## Three Phase Induction Motor - Squirrel Cage

Customer : Dealers Industrial Equipment 800-469-3110  
 Customer reference : 02018OT3H256TC-W40

Product line : W40 NEMA Premium Efficiency Three-Phase      Product code : 14494889  
 Catalog # : 02018OT3H256TC-W40

Frame	: 254/6TC	Locked rotor time	: 21s (cold) 12s (hot)
Output	: 20 HP (15 kW)	Temperature rise	: 80 K
Poles	: 4	Duty cycle	: Cont.(S1)
Frequency	: 60 Hz	Ambient temperature	: -20°C to +40°C
Rated voltage	: 575 V	Altitude	: 1000 m.a.s.l.
Rated current	: 19.3 A	Protection degree	: IP23
L. R. Amperes	: 123 A	Cooling method	: IC01 - ODP
LRC	: 6.4x(Code G)	Mounting	: F-1
No load current	: 8.00 A	Rotation <sup>1</sup>	: Both (CW and CCW)
Rated speed	: 1765 rpm	Noise level <sup>2</sup>	: 62.0 dB(A)
Slip	: 1.94 %	Starting method	: Direct On Line
Rated torque	: 58.7 ft.lb	Approx. weight <sup>3</sup>	: 320 lb
Locked rotor torque	: 220 %		
Breakdown torque	: 280 %		
Insulation class	: F		
Service factor	: 1.25		
Moment of inertia (J)	: 3.13 sq.ft.lb		
Design	: B		

Output	25%	50%	75%	100%	Foundation loads
Efficiency (%)	92.2	92.4	93.0	93.0	Max. traction
Power Factor	0.43	0.69	0.79	0.84	Max. compression

		<u>Drive end</u>	<u>Non drive end</u>
Bearing type	:	6309 Z C3	6209 Z C3
Sealing	:	Without Bearing Seal	Without Bearing Seal
Lubrication interval	:	20000 h	20000 h
Lubricant amount	:	13 g	9 g
Lubricant type	:	Mobil Polyrex EM	

Notes  
 downloaded from <http://dealerselectric.com>

This revision replaces and cancel the previous one, which must be eliminated.  
 (1) Looking the motor from the shaft end.  
 (2) Measured at 1m and with tolerance of +3dB(A).  
 (3) Approximate weight subject to changes after manufacturing process.  
 (4) At 100% of full load.

These are average values based on tests with sinusoidal power supply, subject to the tolerances stipulated in NEMA MG-1.

Rev.	Changes Summary	Performed	Checked	Date
Performed by		Page		Revision
Checked by		1 / 2		
Date	13/04/2019			

# LOAD PERFORMANCE CURVE



## Three Phase Induction Motor - Squirrel Cage

Customer : Dealers Industrial Equipment 800-469-3110  
 Customer reference : 02018OT3H256TC-W40

Product line : W40 NEMA Premium Efficiency Three-Phase      Product code : 14494889  
 Catalog # : 02018OT3H256TC-W40

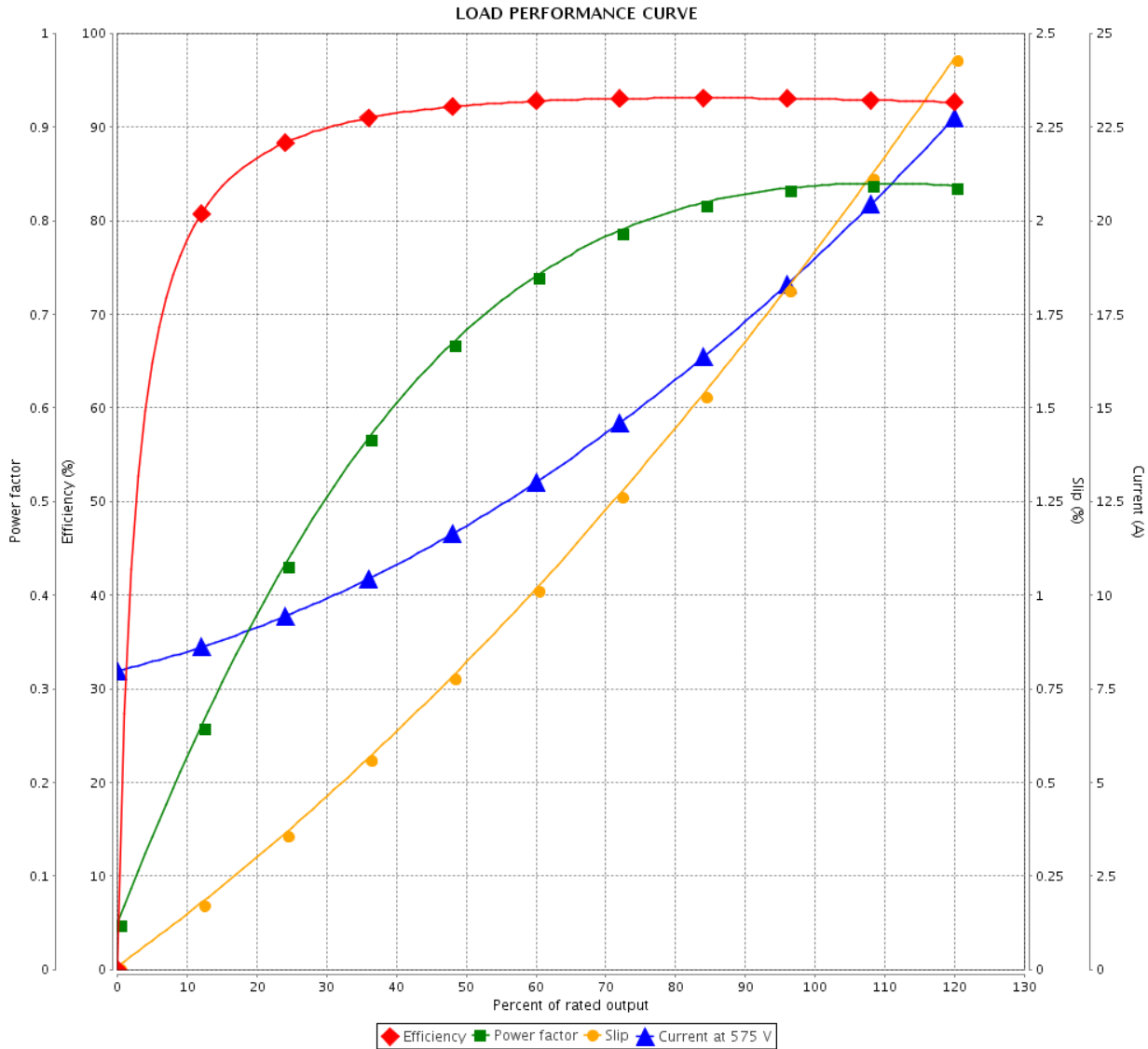

Performance : 575 V 60 Hz 4P

Rated current : 19.3 A	Moment of inertia (J) : 3.13 sq.ft.lb
LRC : 6.4	Duty cycle : Cont.(S1)
Rated torque : 58.7 ft.lb	Insulation class : F
Locked rotor torque : 220 %	Service factor : 1.25
Breakdown torque : 280 %	Temperature rise : 80 K
Rated speed : 1765 rpm	Design : B

Rev.	Changes Summary	Performed	Checked	Date
Performed by			Page 2 / 2	Revision
Checked by				
Date	13/04/2019			

Dimensões em polegada  
Dimensions in inches

THIS IS AN UPDATED REVISION, THE  
PREVIOUS ONE MUST BE DISREGARDED.

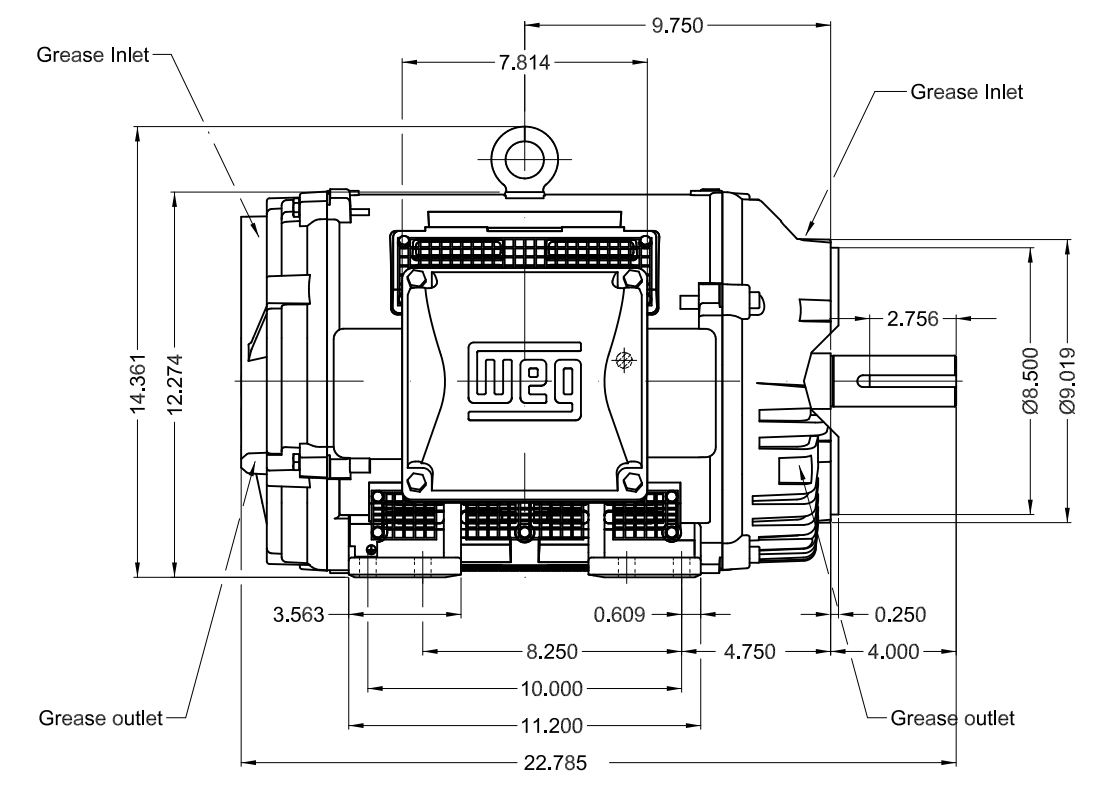
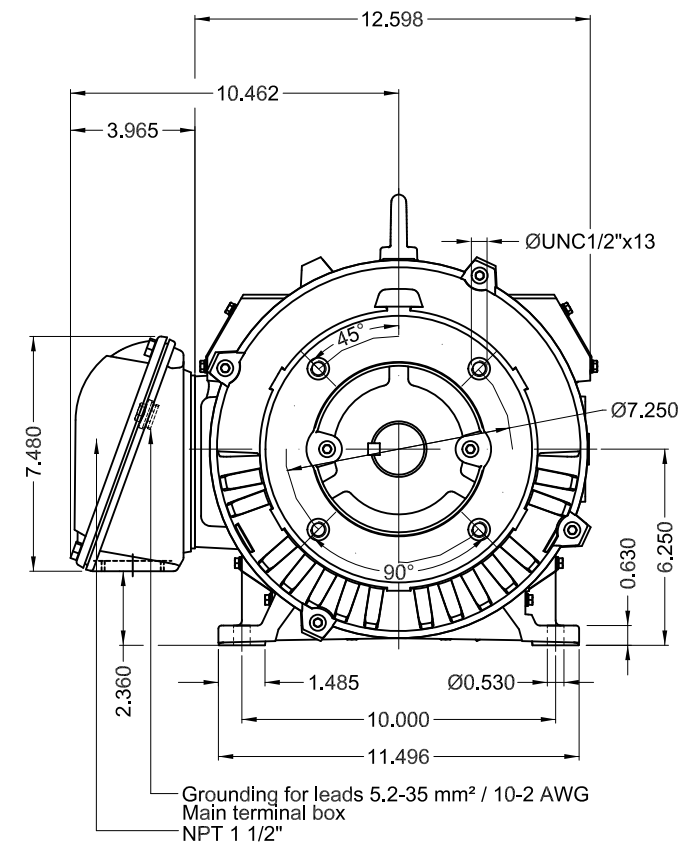

Bearing cap									
Color RAL 5009									
Painting plan 203A									
Mounting B34R(D)									
					SCALE	1:6			
ECM	LOC	SUMMARY OF MODIFICATIONS			EXECUTED	CHECKED	RELEASED	DATE	VER
EXECUTED	USERADMIN	THREE PHASE W40 MOTOR NEMA PREMIUM EFF							
CHECKED		FRAME 254/6TC IP23 ODP							
RELEASED		WEG code: 14494889							
REL DT	13.04.2019	WMO	Jaragua do Sul	Product Engineering	SHEET	1 / 1			

20 HP 04 Poles 60Hz

A

