

LOAD PERFORMANCE CURVE



Three Phase Induction Motor - Squirrel Cage

Customer : Dealers Industrial Equipment 800-469-3110
 Customer reference : 02012OT3H286T-W40

Product line : W40 NEMA Premium Efficiency Three-Phase Product code : 14494189
 Catalog # : 02012OT3H286T-W40

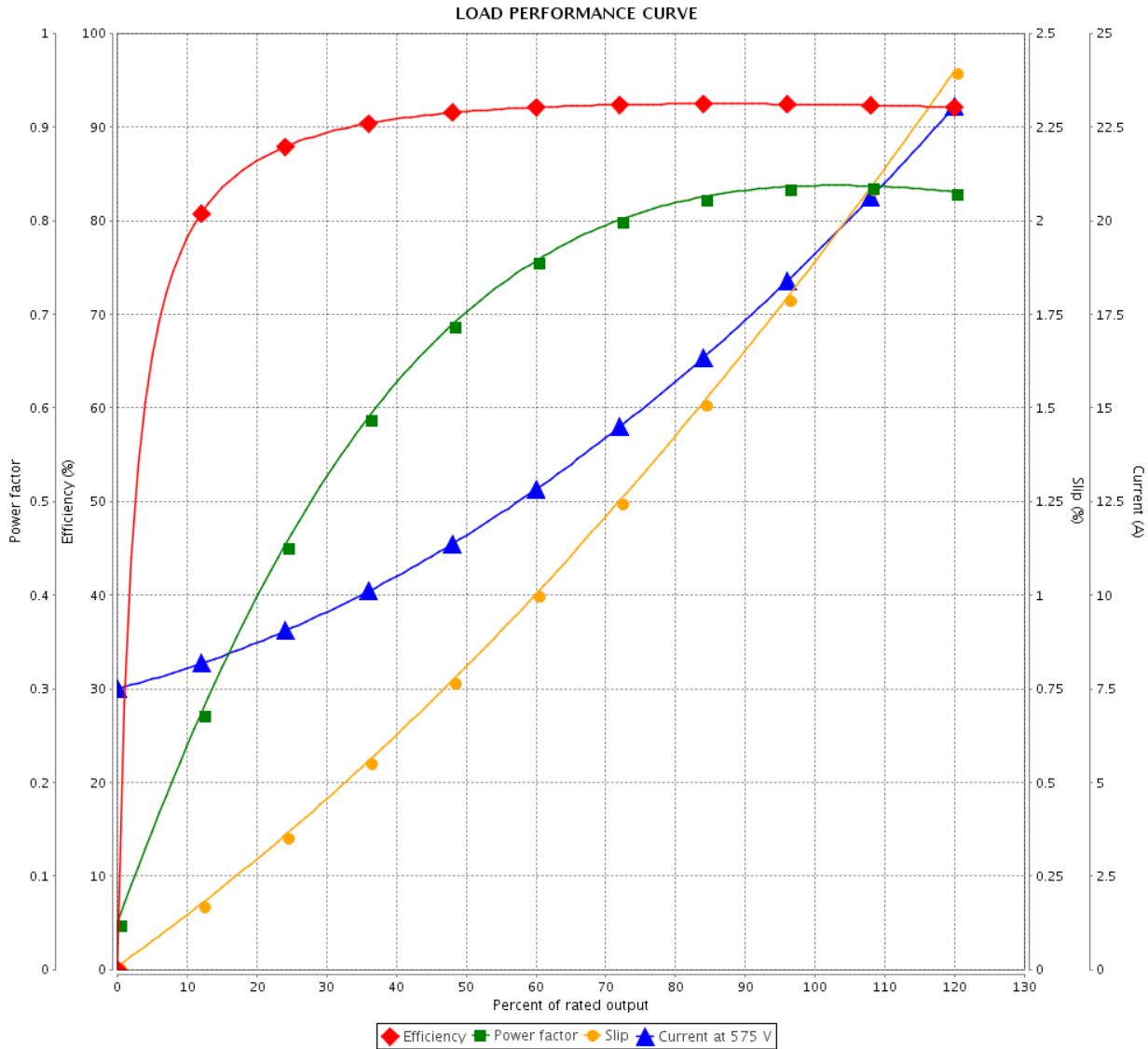

Performance : 575 V 60 Hz 6P

Rated current : 19.4 A	Moment of inertia (J) : 6.89 sq.ft.lb
LRC : 6.4	Duty cycle : Cont.(S1)
Rated torque : 88.0 ft.lb	Insulation class : F
Locked rotor torque : 229 %	Service factor : 1.25
Breakdown torque : 260 %	Temperature rise : 80 K
Rated speed : 1177 rpm	Design : B

Rev.	Changes Summary	Performed	Checked	Date
Performed by			Page 2 / 2	Revision
Checked by				
Date	13/04/2019			

Dimensões em polegada
Dimensions in inches

THIS IS AN UPDATED REVISION, THE
PREVIOUS ONE MUST BE DISREGARDED.

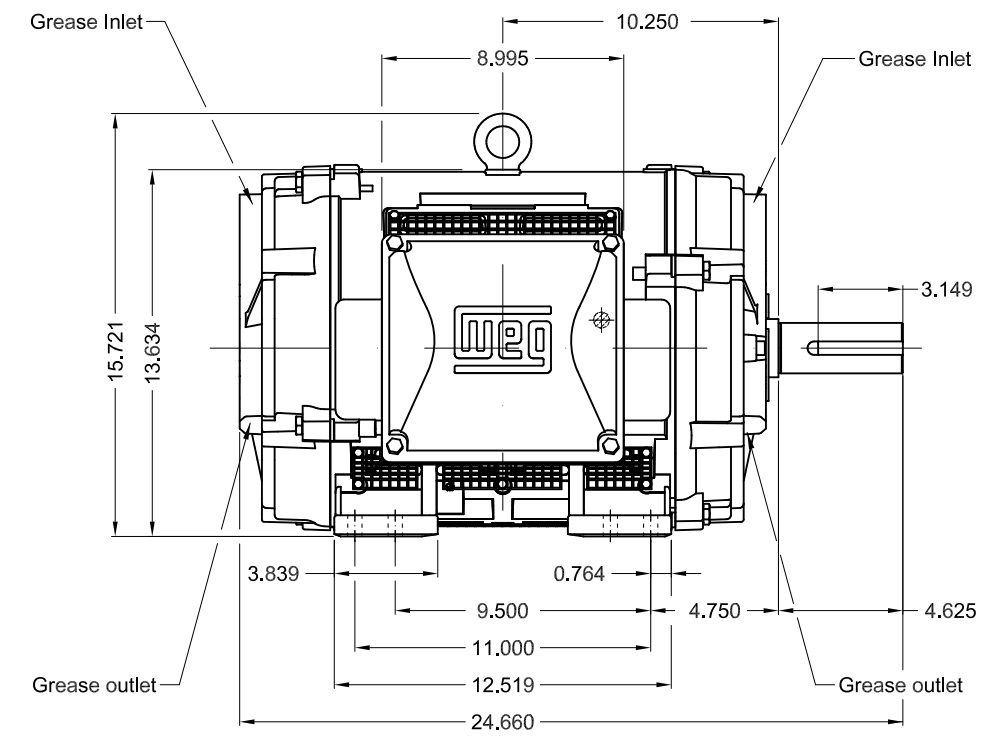
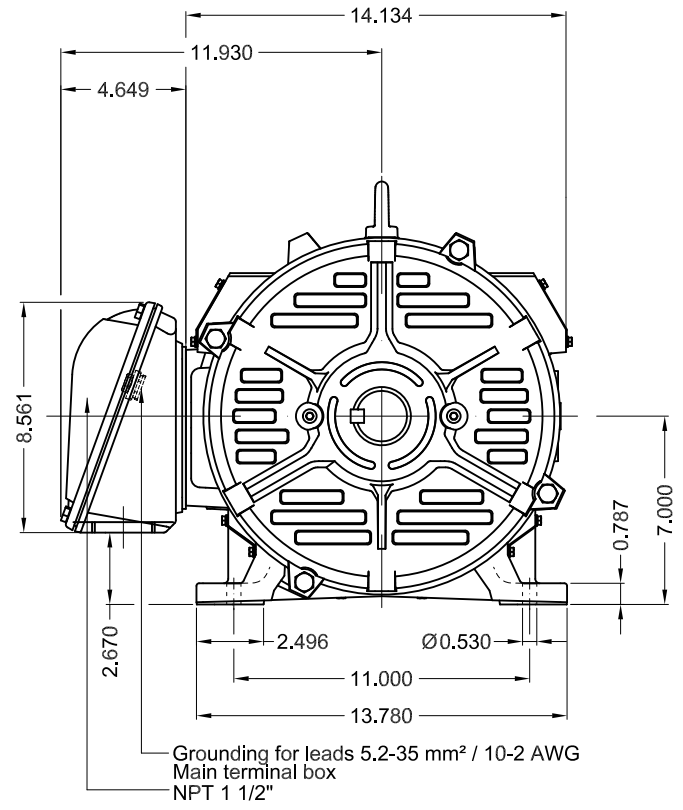

Color RAL 5009						
Painting plan 203A						
Mounting B3R(D)						
					SCALE	1:7
ECM	LOC	SUMMARY OF MODIFICATIONS			EXECUTED	CHECKED
EXECUTED	USERADMIN	THREE PHASE W40 MOTOR NEMA PREMIUM EFF				
CHECKED		FRAME 284/6T IP23 ODP				
RELEASED		WEG code: 14494189				
REL DT	13.04.2019	WMO	Jaragua do Sul	Product Engineering	SHEET	1 / 1

20 HP 06 Poles 60Hz

A

