

DATA SHEET



Three Phase Induction Motor - Squirrel Cage

Customer : Dealers Industrial Equipment 800-469-3110					
Customer reference : 04018OT3E324TF2-W40					
Product line : W40 NEMA Premium Efficiency Three-Phase		Product code :	14493474		
		Catalog # :	04018OT3E324TF2-W40		
Frame : 324T	Locked rotor time : 23s (cold) 13s (hot)	Output : 40 HP (30 kW)	Temperature rise : 80 K		
Poles : 4	Duty cycle : Cont.(S1)	Frequency : 60 Hz	Ambient temperature : -20°C to +40°C		
Rated voltage : 208-230/460 V	Altitude : 1000 m.a.s.l.	Rated current : 105-95.2/47.6 A	Protection degree : IP23		
L. R. Amperes : 653-590/295 A	Cooling method : IC01 - ODP	LRC : 6.2x(Code G)	Mounting : F-2		
No load current : 31.9-37.0/18.5 A	Rotation ¹ : Both (CW and CCW)	Rated speed : 1775 rpm	Noise level ² : 66.0 dB(A)		
Slip : 1.39 %	Starting method : Direct On Line	Rated torque : 117 ft.lb	Approx. weight ³ : 472 lb		
Locked rotor torque : 200 %		Breakdown torque : 240 %			
Insulation class : F		Service factor : 1.25			
Moment of inertia (J) : 5.69 sq.ft.lb		Design : B			
Output	25%	50%	75%	100%	
Efficiency (%)	93.5	93.6	94.1	94.1	
Power Factor	0.44	0.70	0.80	0.84	
Foundation loads					
Max. traction					
Max. compression					
		<u>Drive end</u>		<u>Non drive end</u>	
Bearing type :	6312 Z C3		6211 Z C3		
Sealing :	Without Bearing Seal		Without Bearing Seal		
Lubrication interval :	20000 h		20000 h		
Lubricant amount :	21 g		11 g		
Lubricant type :	Mobil Polyrex EM				
Notes downloaded from http://dealerselectric.com					
This revision replaces and cancel the previous one, which must be eliminated. (1) Looking the motor from the shaft end. (2) Measured at 1m and with tolerance of +3dB(A). (3) Approximate weight subject to changes after manufacturing process. (4) At 100% of full load.			These are average values based on tests with sinusoidal power supply, subject to the tolerances stipulated in NEMA MG-1.		
Rev.	Changes Summary		Performed	Checked	Date
Performed by					
Checked by				Page	Revision
Date	14/04/2019			1 / 2	

LOAD PERFORMANCE CURVE



Three Phase Induction Motor - Squirrel Cage

Customer : Dealers Industrial Equipment 800-469-3110
 Customer reference : 04018OT3E324TF2-W40

Product line : W40 NEMA Premium Efficiency Three-Phase Product code : 14493474
 Catalog # : 04018OT3E324TF2-W40

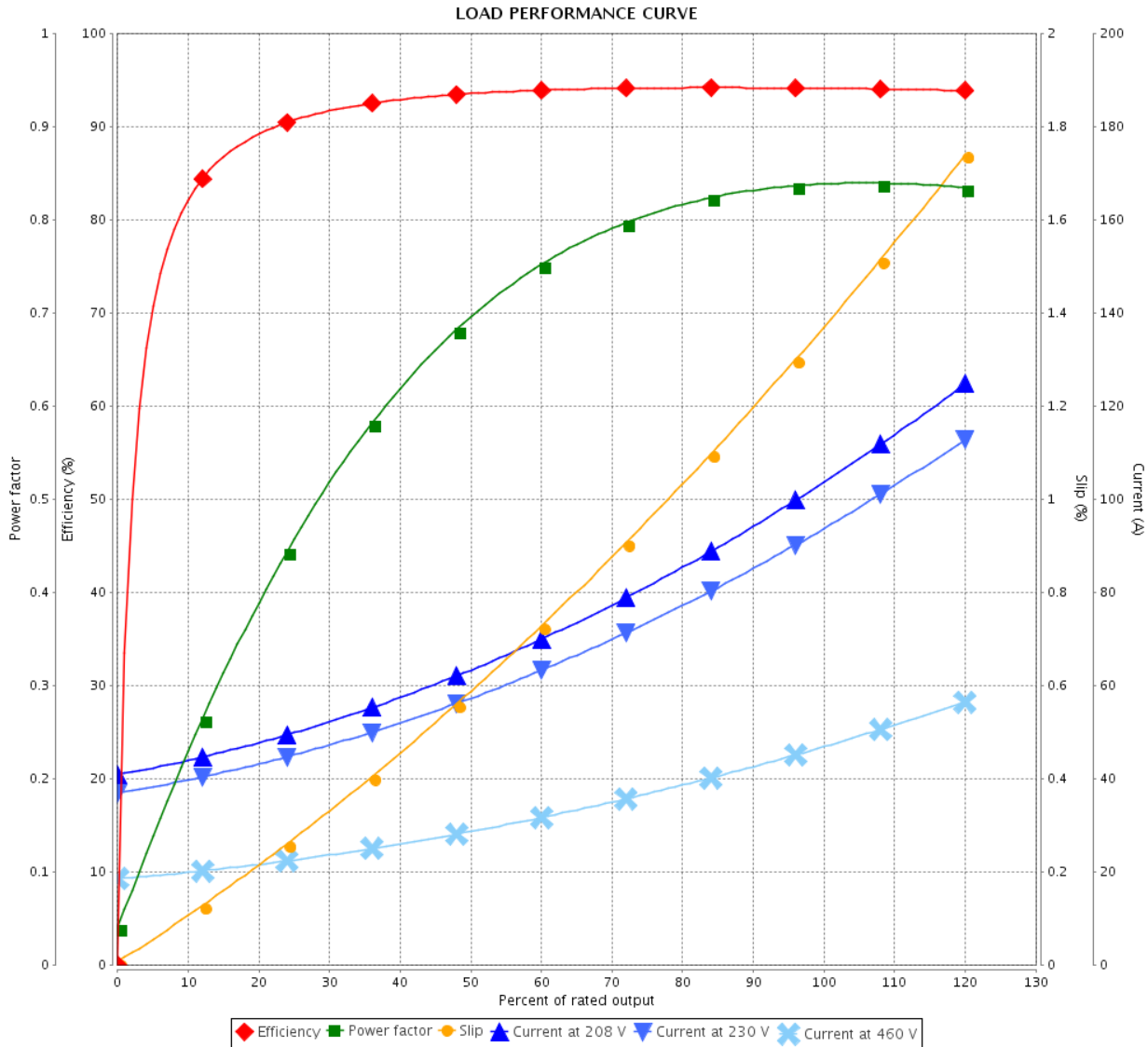

Performance : 208-230/460 V 60 Hz 4P

Rated current : 105-95.2/47.6 A	Moment of inertia (J) : 5.69 sq.ft.lb
LRC : 6.2	Duty cycle : Cont.(S1)
Rated torque : 117 ft.lb	Insulation class : F
Locked rotor torque : 200 %	Service factor : 1.25
Breakdown torque : 240 %	Temperature rise : 80 K
Rated speed : 1775 rpm	Design : B

Rev.	Changes Summary	Performed	Checked	Date
Performed by			Page	Revision
Checked by				
Date				

Dimensões em polegada
Dimensions in inches

THIS IS AN UPDATED REVISION, THE
PREVIOUS ONE MUST BE DISREGARDED.

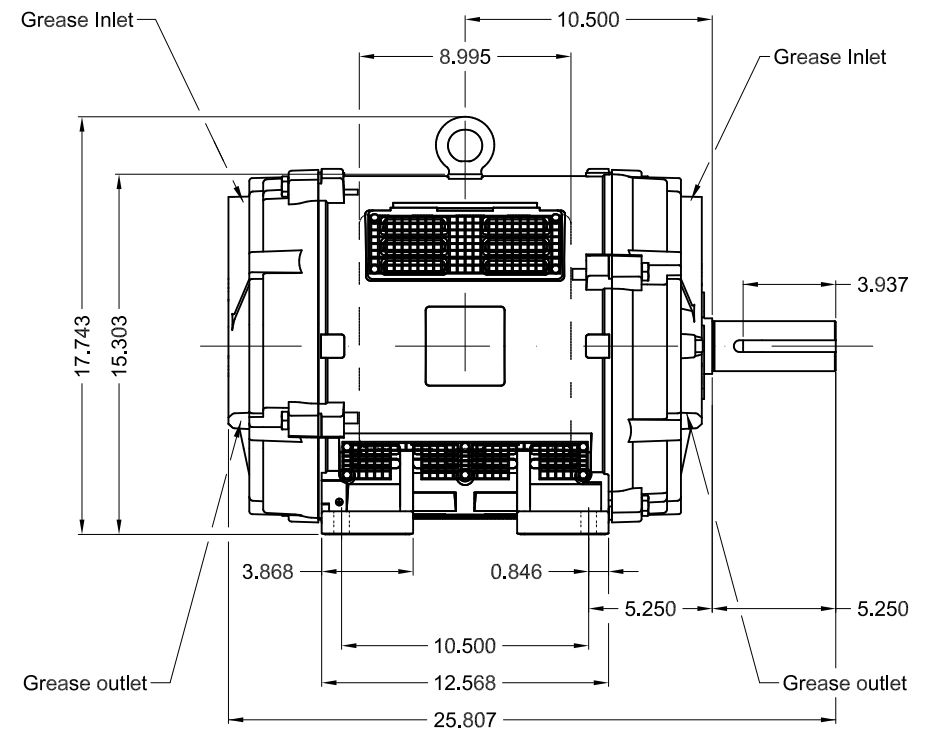
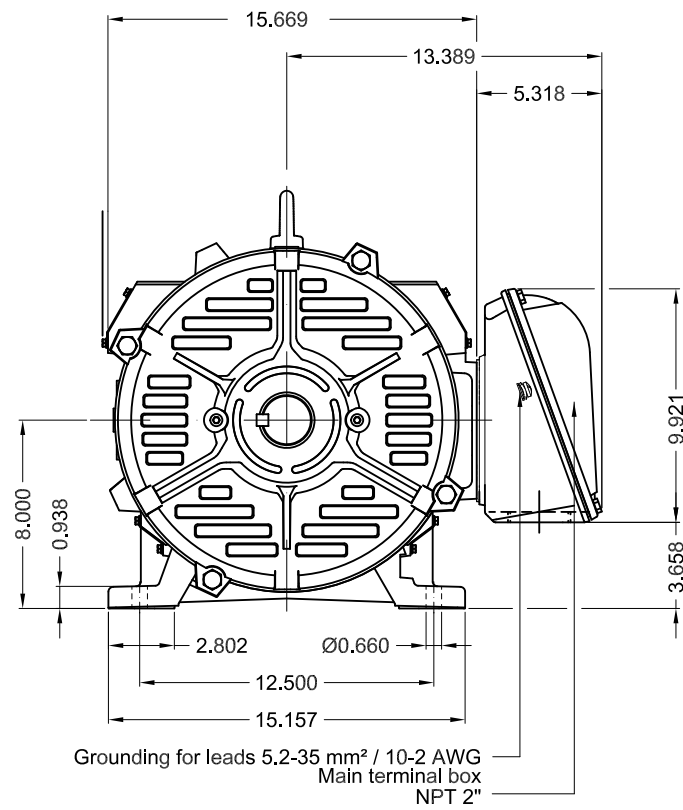

Color RAL 5009
Painting plan 203A
Mounting B3L(E)

SCALE 1:8

ECM	LOC	SUMMARY OF MODIFICATIONS	EXECUTED	CHECKED	RELEASED	DATE	VER
EXECUTED	USERADMIN	THREE PHASE W40 MOTOR NEMA PREMIUM EFF					
CHECKED		FRAME 324T IP23 ODP					
RELEASED		WEG code: 14493474					
REL DT	14.04.2019	WMO Jaragua do Sul	Product Engineering	SHEET	1 / 1		



40 HP 04 Poles 60Hz

A