

DATA SHEET



Three Phase Induction Motor - Squirrel Cage

Customer : Dealers Industrial Equipment 800-469-3110
 Customer reference : 03036OP3HFP284TS-W40

Product line : W40 High Efficiency Three-Phase Product code : 14490718
 Catalog # : 03036OP3HFP284TS-W40

Frame : 284TS	Locked rotor time : 28s (cold) 16s (hot)
Output : 30 HP (22 kW)	Temperature rise : 105 K
Poles : 2	Duty cycle : Cont.(S1)
Frequency : 60 Hz	Ambient temperature : -20°C to +40°C
Rated voltage : 575 V	Altitude : 1000 m.a.s.l.
Rated current : 27.9 A	Protection degree : IP23
L. R. Amperes : 173 A	Cooling method : IC01 - ODP
LRC : 6.2x(Code G)	Mounting : F-1
No load current : 8.80 A	Rotation ¹ : Both (CW and CCW)
Rated speed : 3540 rpm	Starting method : Direct On Line
Slip : 1.67 %	Approx. weight ³ : 324 lb
Rated torque : 43.9 ft.lb	
Locked rotor torque : 170 %	
Breakdown torque : 260 %	
Insulation class : F	
Service factor : 1.15	
Moment of inertia (J) : 1.59 sq.ft.lb	
Design : B	

Output	25%	50%	75%	100%	Foundation loads
Efficiency (%)	90.0	90.2	91.0	91.0	Max. traction
Power Factor	0.50	0.74	0.83	0.87	Max. compression

	<u>Drive end</u>	<u>Non drive end</u>
Bearing type :	6311 Z C3	6211 Z C3
Sealing :	Without Bearing Seal	Without Bearing Seal
Lubrication interval :	20000 h	20000 h
Lubricant amount :	18 g	11 g
Lubricant type :	Mobil Polyrex EM	

Notes
 downloaded from <http://dealerselectric.com>

This revision replaces and cancel the previous one, which must be eliminated.
 (1) Looking the motor from the shaft end.
 (2) Measured at 1m and with tolerance of +3dB(A).
 (3) Approximate weight subject to changes after manufacturing process.
 (4) At 100% of full load.

These are average values based on tests with sinusoidal power supply, subject to the tolerances stipulated in NEMA MG-1.

Rev.	Changes Summary	Performed	Checked	Date
Performed by				
Checked by			Page	Revision
Date	14/04/2019		1 / 2	

LOAD PERFORMANCE CURVE



Three Phase Induction Motor - Squirrel Cage

Customer : Dealers Industrial Equipment 800-469-3110
 Customer reference : 03036OP3HFP284TS-W40

Product line : W40 High Efficiency Three-Phase Product code : 14490718
 Catalog # : 03036OP3HFP284TS-W40

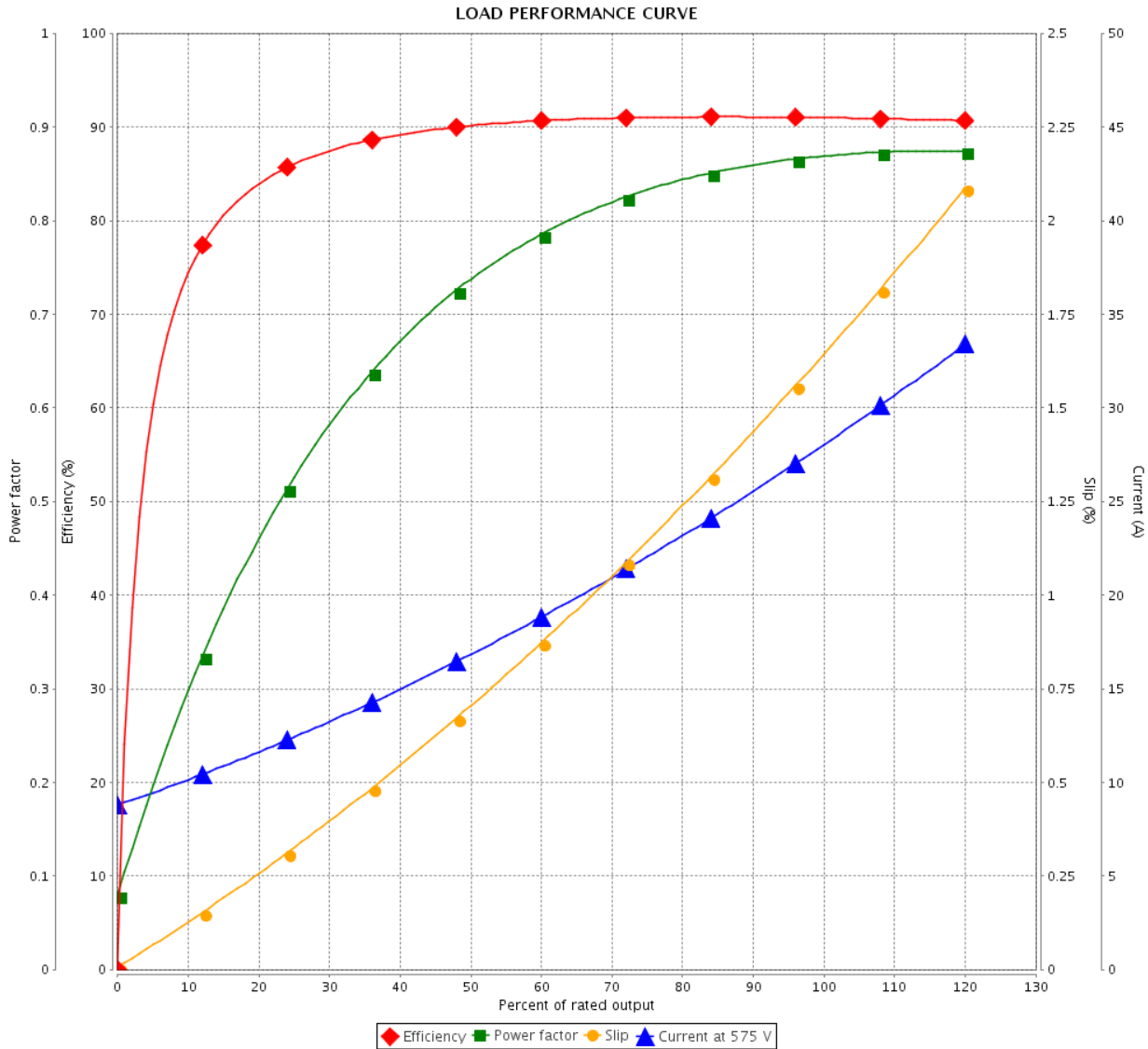

Performance : 575 V 60 Hz 2P

Rated current : 27.9 A	Moment of inertia (J) : 1.59 sq.ft.lb
LRC : 6.2	Duty cycle : Cont.(S1)
Rated torque : 43.9 ft.lb	Insulation class : F
Locked rotor torque : 170 %	Service factor : 1.15
Breakdown torque : 260 %	Temperature rise : 105 K
Rated speed : 3540 rpm	Design : B

Rev.	Changes Summary	Performed	Checked	Date
Performed by			Page	Revision
Checked by				
Date				

Dimensões em polegada
Dimensions in inches

THIS IS AN UPDATED REVISION, THE
PREVIOUS ONE MUST BE DISREGARDED.

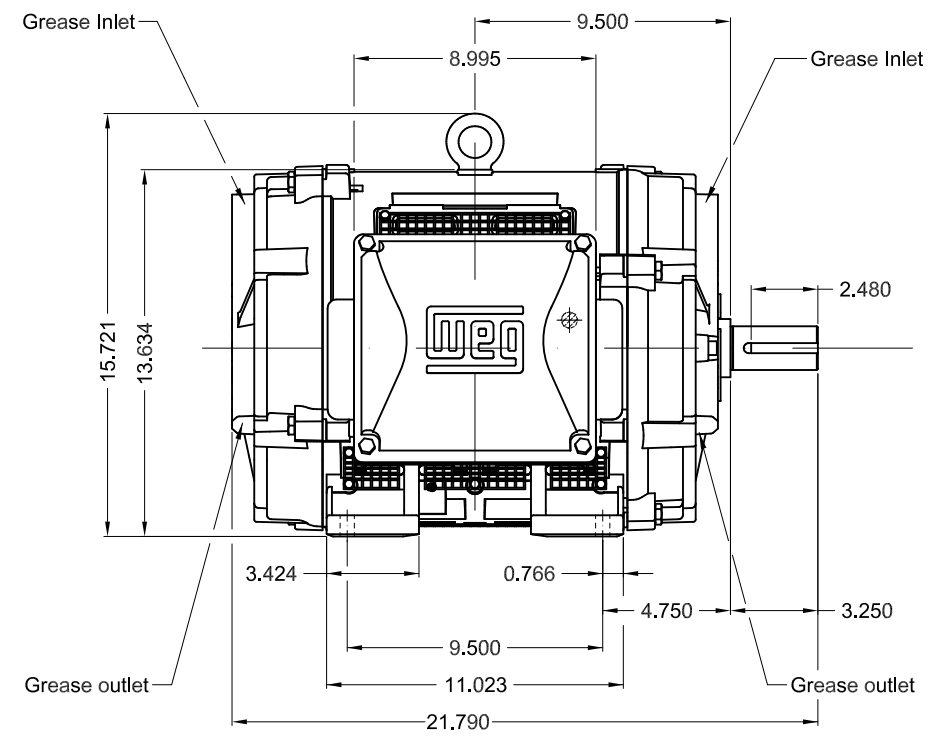
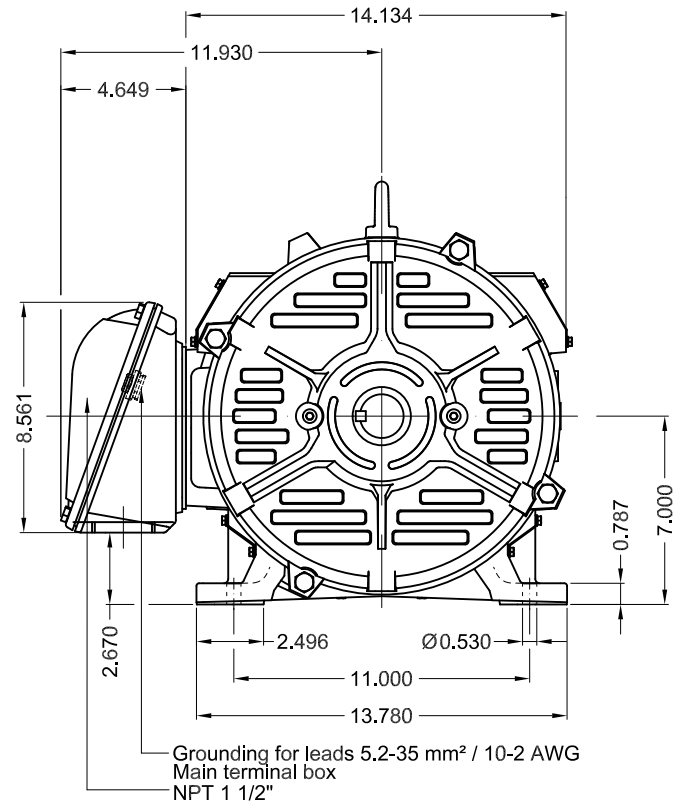

Color RAL 3002						
Painting plan 203A						
Mounting B3R(D)						
					SCALE	1:7
ECM	LOC	SUMMARY OF MODIFICATIONS			EXECUTED	CHECKED
EXECUTED	USERADMIN	THREE PHASE W40 MOTOR HIGH EFF				
CHECKED		FRAME 284TS IP23 ODP				
RELEASED		WEG code: 14490718				
REL DT	14.04.2019	WMO	Jaragua do Sul	Product Engineering	SHEET	1 / 1

30 HP 02 Poles 60Hz

A

