

DATA SHEET



Three Phase Induction Motor - Squirrel Cage

Customer	: Dealers Industrial Equipment 800-469-3110					
Customer reference	: 03036OP3EFP284TS-W40					
Product line	: W40 High Efficiency Three-Phase	Product code :	14490665			
		Catalog # :	03036OP3EFP284TS-W40			
Frame	: 284TS	Locked rotor time	: 28s (cold) 16s (hot)			
Output	: 30 HP (22 kW)	Temperature rise	: 105 K			
Poles	: 2	Duty cycle	: Cont.(S1)			
Frequency	: 60 Hz	Ambient temperature	: -20°C to +40°C			
Rated voltage	: 208-230/460 V	Altitude	: 1000 m.a.s.l.			
Rated current	: 77.2-69.8/34.9 A	Protection degree	: IP23			
L. R. Amperes	: 479-433/216 A	Cooling method	: IC01 - ODP			
LRC	: 6.2x(Code G)	Mounting	: F-1			
No load current	: 19.0-22.0/11.0 A	Rotation ¹	: Both (CW and CCW)			
Rated speed	: 3540 rpm	Starting method	: Direct On Line			
Slip	: 1.67 %	Approx. weight ³	: 301 lb			
Rated torque	: 43.9 ft.lb					
Locked rotor torque	: 170 %					
Breakdown torque	: 260 %					
Insulation class	: F					
Service factor	: 1.15					
Moment of inertia (J)	: 1.59 sq.ft.lb					
Design	: B					
Output	25%	50%	75%	100%		
Efficiency (%)	90.0	90.2	91.0	91.0		
Power Factor	0.50	0.74	0.83	0.87		
				Foundation loads		
				Max. traction		
				Max. compression		
		<u>Drive end</u>		<u>Non drive end</u>		
Bearing type	:	6311 Z C3		6211 Z C3		
Sealing	:	Without Bearing Seal		Without Bearing Seal		
Lubrication interval	:	20000 h		20000 h		
Lubricant amount	:	18 g		11 g		
Lubricant type	:	Mobil Polyrex EM				
Notes downloaded from http://dealerselectric.com						
This revision replaces and cancel the previous one, which must be eliminated. (1) Looking the motor from the shaft end. (2) Measured at 1m and with tolerance of +3dB(A). (3) Approximate weight subject to changes after manufacturing process. (4) At 100% of full load.			These are average values based on tests with sinusoidal power supply, subject to the tolerances stipulated in NEMA MG-1.			
Rev.	Changes Summary			Performed	Checked	Date
Performed by						
Checked by					Page	Revision
Date	14/04/2019				1 / 2	

LOAD PERFORMANCE CURVE



Three Phase Induction Motor - Squirrel Cage

Customer : Dealers Industrial Equipment 800-469-3110
 Customer reference : 03036OP3EFP284TS-W40

Product line : W40 High Efficiency Three-Phase Product code : 14490665
 Catalog # : 03036OP3EFP284TS-W40

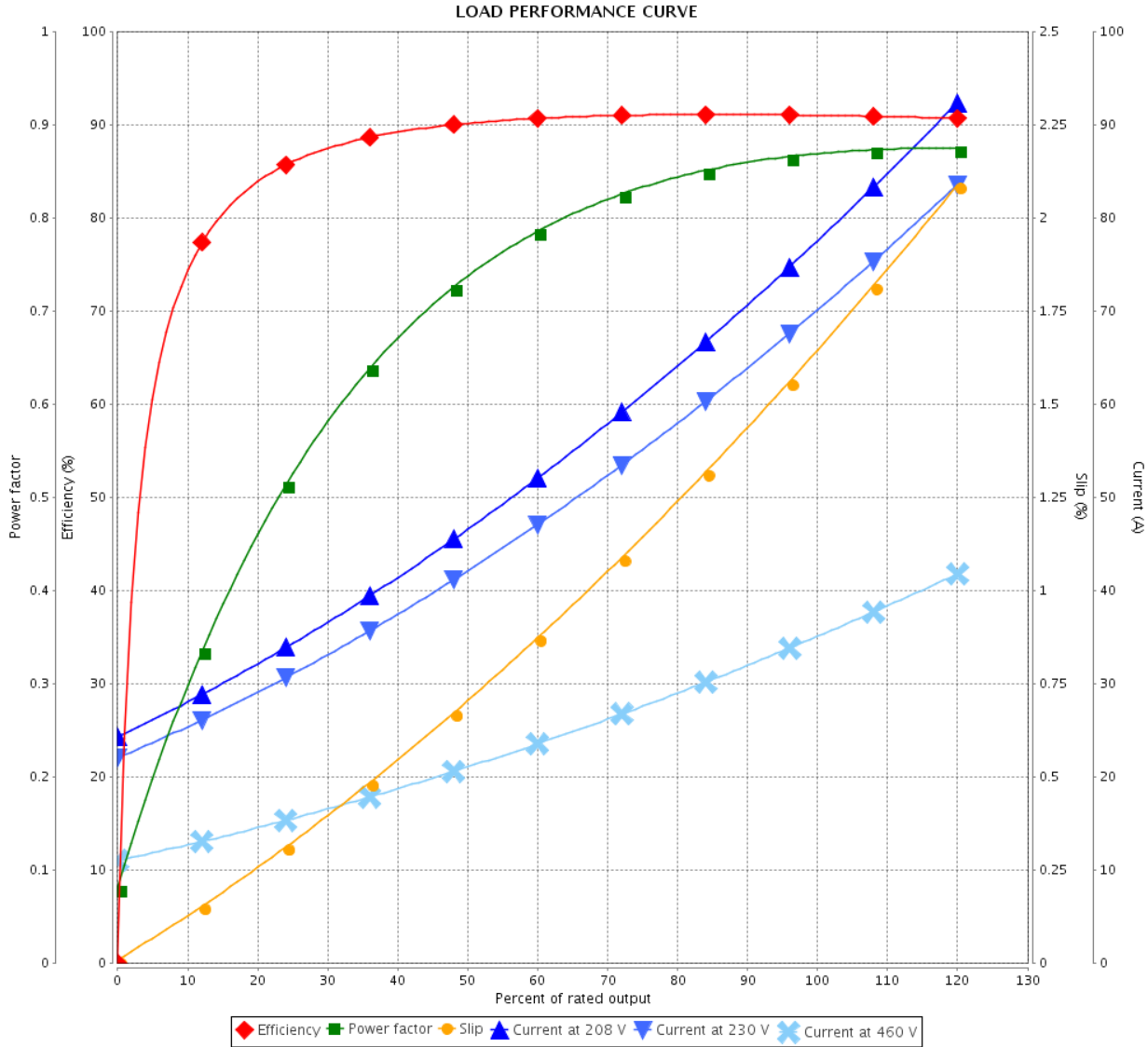

Performance : 208-230/460 V 60 Hz 2P

Rated current : 77.2-69.8/34.9 A	Moment of inertia (J) : 1.59 sq.ft.lb
LRC : 6.2	Duty cycle : Cont.(S1)
Rated torque : 43.9 ft.lb	Insulation class : F
Locked rotor torque : 170 %	Service factor : 1.15
Breakdown torque : 260 %	Temperature rise : 105 K
Rated speed : 3540 rpm	Design : B

Rev.	Changes Summary	Performed	Checked	Date
Performed by			Page 2 / 2	Revision
Checked by				
Date	14/04/2019			

Dimensões em polegada
Dimensions in inches

THIS IS AN UPDATED REVISION, THE
PREVIOUS ONE MUST BE DISREGARDED.

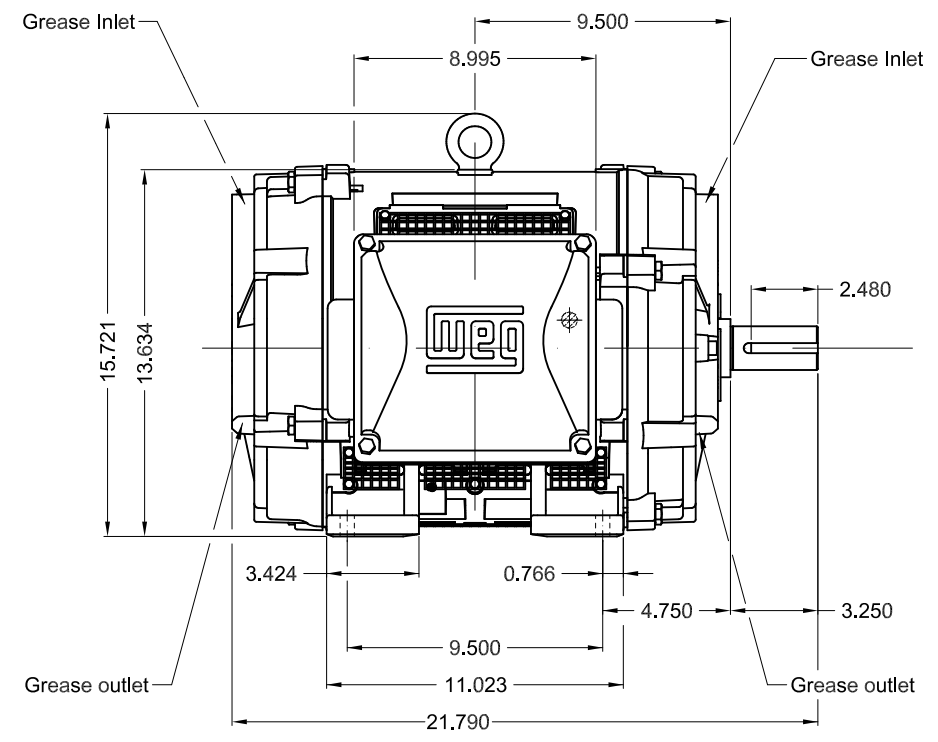
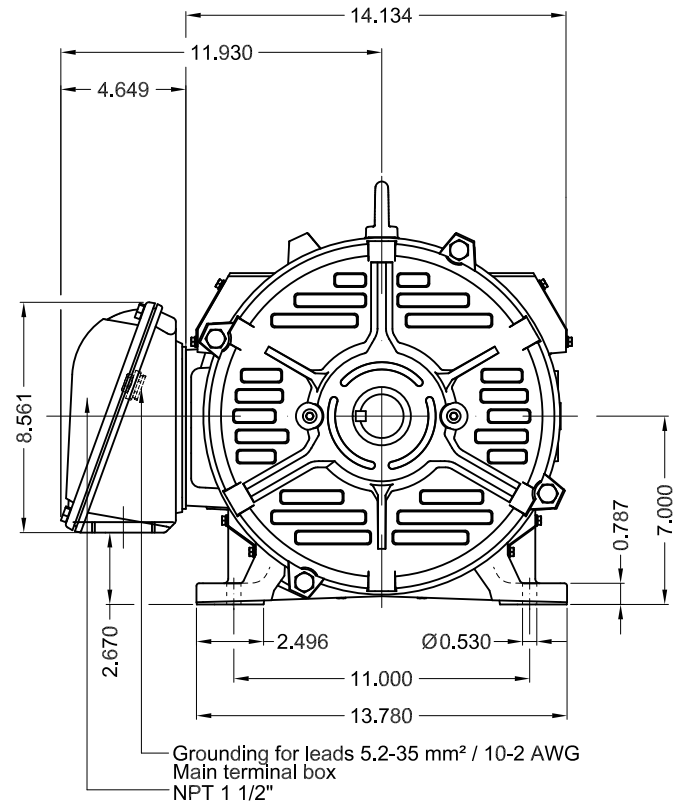

Color RAL 3002						
Painting plan 203A						
Mounting B3R(D)						
					SCALE	1:7
ECM	LOC	SUMMARY OF MODIFICATIONS			EXECUTED	CHECKED
EXECUTED	USERADMIN	THREE PHASE W40 MOTOR HIGH EFF				
CHECKED		FRAME 284TS IP23 ODP				
RELEASED		WEG code: 14490665				
REL DT	14.04.2019	WMO	Jaragua do Sul	Product Engineering	SHEET	1 / 1

30 HP 02 Poles 60Hz

A

