

DATA SHEET



Three Phase Induction Motor - Squirrel Cage

Customer	: Dealers Industrial Equipment 800-469-3110					
Customer reference	: 03018OP3VFP286TS-W40					
Product line	: W40 High Efficiency Three-Phase	Product code :	14490663			
		Catalog # :	03018OP3VFP286TS-W40			
Frame	: 284/6TS	Locked rotor time	: 39s (cold) 22s (hot)			
Output	: 30 HP (22 kW)	Temperature rise	: 105 K			
Poles	: 4	Duty cycle	: Cont.(S1)			
Frequency	: 60 Hz	Ambient temperature	: -20°C to +40°C			
Rated voltage	: 200/400 V	Altitude	: 1000 m.a.s.l.			
Rated current	: 81.9/40.9 A	Protection degree	: IP23			
L. R. Amperes	: 516/258 A	Cooling method	: IC01 - ODP			
LRC	: 6.3x(Code G)	Mounting	: F-1			
No load current	: 25.3/12.7 A	Rotation ¹	: Both (CW and CCW)			
Rated speed	: 1765 rpm	Starting method	: Direct On Line			
Slip	: 1.94 %	Approx. weight ³	: 381 lb			
Rated torque	: 88.1 ft.lb					
Locked rotor torque	: 250 %					
Breakdown torque	: 270 %					
Insulation class	: F					
Service factor	: 1.15					
Moment of inertia (J)	: 3.70 sq.ft.lb					
Design	: B					
Output	25%	50%	75%	100%		
Efficiency (%)	91.5	91.7	92.4	92.4		
Power Factor	0.49	0.71	0.80	0.84		
				Foundation loads		
				Max. traction		
				Max. compression		
		<u>Drive end</u>		<u>Non drive end</u>		
Bearing type	:	6311 Z C3		6211 Z C3		
Sealing	:	Without Bearing Seal		Without Bearing Seal		
Lubrication interval	:	20000 h		20000 h		
Lubricant amount	:	18 g		11 g		
Lubricant type	:	Mobil Polyrex EM				
Notes downloaded from http://dealerselectric.com						
This revision replaces and cancel the previous one, which must be eliminated. (1) Looking the motor from the shaft end. (2) Measured at 1m and with tolerance of +3dB(A). (3) Approximate weight subject to changes after manufacturing process. (4) At 100% of full load.			These are average values based on tests with sinusoidal power supply, subject to the tolerances stipulated in NEMA MG-1.			
Rev.	Changes Summary			Performed	Checked	Date
Performed by						
Checked by					Page	Revision
Date	14/04/2019				1 / 2	

LOAD PERFORMANCE CURVE



Three Phase Induction Motor - Squirrel Cage

Customer : Dealers Industrial Equipment 800-469-3110
 Customer reference : 03018OP3VFP286TS-W40

Product line : W40 High Efficiency Three-Phase Product code : 14490663
 Catalog # : 03018OP3VFP286TS-W40

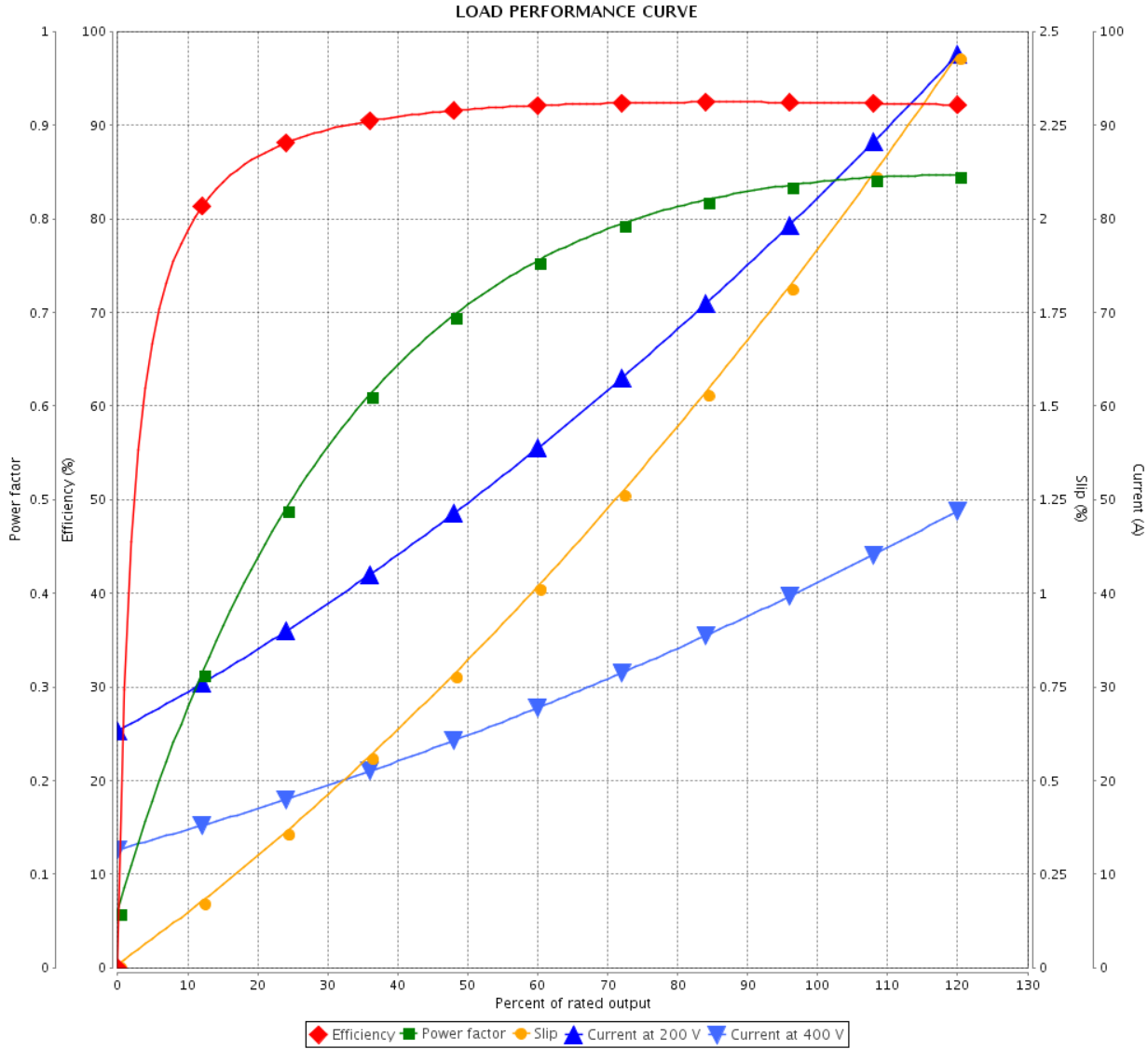

Performance : 200/400 V 60 Hz 4P

Rated current : 81.9/40.9 A	Moment of inertia (J) : 3.70 sq.ft.lb
LRC : 6.3	Duty cycle : Cont.(S1)
Rated torque : 88.1 ft.lb	Insulation class : F
Locked rotor torque : 250 %	Service factor : 1.15
Breakdown torque : 270 %	Temperature rise : 105 K
Rated speed : 1765 rpm	Design : B

Rev.	Changes Summary	Performed	Checked	Date
Performed by			Page	Revision
Checked by				
Date				

Dimensões em polegada
Dimensions in inches

THIS IS AN UPDATED REVISION, THE
PREVIOUS ONE MUST BE DISREGARDED.

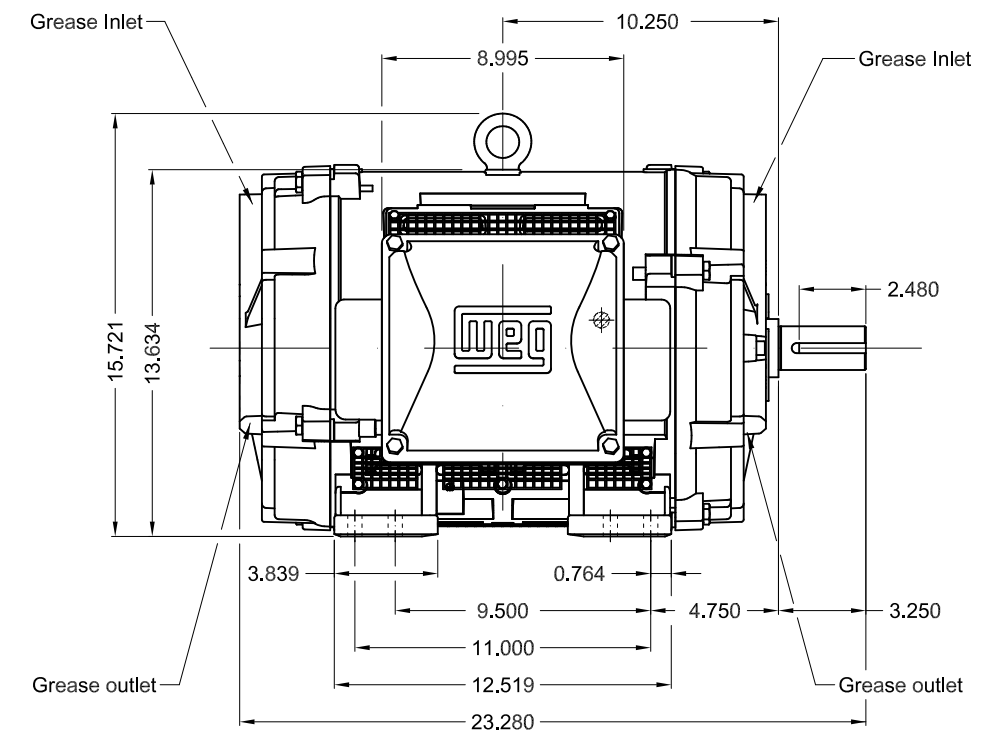
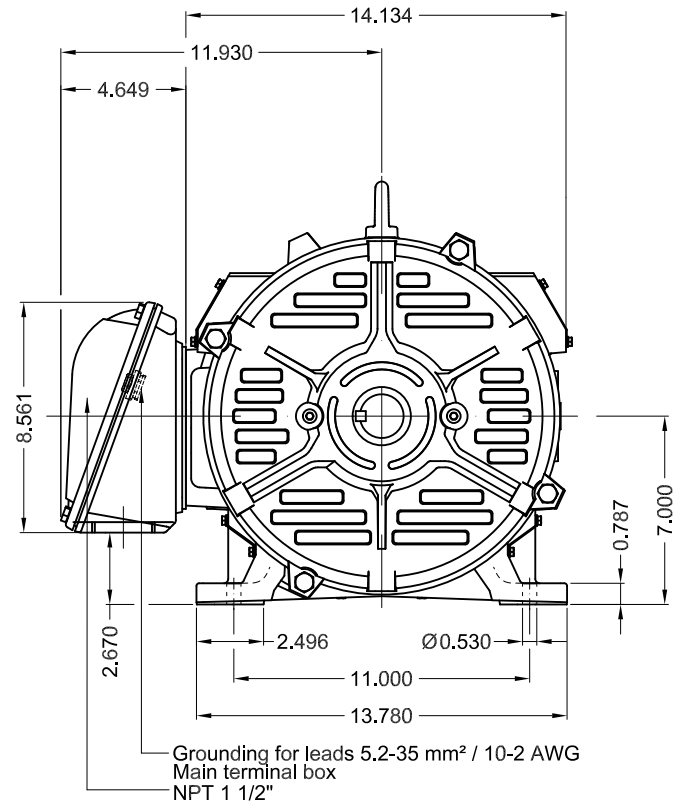

TS shaft end									
Color RAL 3002									
Painting plan 203A									
Mounting B3R(D)									
					SCALE	1:7			
ECM	LOC	SUMMARY OF MODIFICATIONS			EXECUTED	CHECKED	RELEASED	DATE	VER
EXECUTED	USERADMIN	THREE PHASE W40 MOTOR HIGH EFF							
CHECKED		FRAME 284/6TS IP23 ODP							
RELEASED		WEG code: 14490663							
REL DT	14.04.2019	WMO	Jaragua do Sul	Product Engineering	SHEET	1 / 1			

30 HP 04 Poles 60Hz

A

