

DATA SHEET



Three Phase Induction Motor - Squirrel Cage

Customer : Dealers Industrial Equipment 800-469-3110		Customer reference : 05018OT3E326T-W40				
Product line : W40 NEMA Premium Efficiency Three-Phase		Product code : 14367636	Catalog # : 05018OT3E326T-W40			
Frame : 324/6T Output : 50 HP (37 kW) Poles : 4 Frequency : 60 Hz Rated voltage : 208-230/460 V Rated current : 129-117/58.5 A L. R. Amperes : 815-737/369 A LRC : 6.3x(Code G) No load current : 40.0-46.4/23.2 A Rated speed : 1775 rpm Slip : 1.39 % Rated torque : 146 ft.lb Locked rotor torque : 240 % Breakdown torque : 240 % Insulation class : F Service factor : 1.25 Moment of inertia (J) : 7.08 sq.ft.lb Design : B	Locked rotor time : 19s (cold) 11s (hot) Temperature rise : 80 K Duty cycle : Cont.(S1) Ambient temperature : -20°C to +40°C Altitude : 1000 m.a.s.l. Protection degree : IP23 Cooling method : IC01 - ODP Mounting : F-1 Rotation ¹ : Both (CW and CCW) Noise level ² : 66.0 dB(A) Starting method : Direct On Line Approx. weight ³ : 515 lb					
Output	25%	50%	75%	100%	Foundation loads	
Efficiency (%)	94.0	94.1	94.5	94.5	Max. traction	
Power Factor	0.44	0.70	0.80	0.84	Max. compression	
		<u>Drive end</u>		<u>Non drive end</u>		
Bearing type	:	6312 Z C3		6211 Z C3		
Sealing	:	Without Bearing Seal		Without Bearing Seal		
Lubrication interval	:	20000 h		20000 h		
Lubricant amount	:	21 g		11 g		
Lubricant type	:	Mobil Polyrex EM				
Notes downloaded from http://dealerselectric.com						
This revision replaces and cancel the previous one, which must be eliminated. (1) Looking the motor from the shaft end. (2) Measured at 1m and with tolerance of +3dB(A). (3) Approximate weight subject to changes after manufacturing process. (4) At 100% of full load.			These are average values based on tests with sinusoidal power supply, subject to the tolerances stipulated in NEMA MG-1.			
Rev.	Changes Summary			Performed	Checked	Date
Performed by						
Checked by					Page	Revision
Date	14/04/2019				1 / 2	

LOAD PERFORMANCE CURVE



Three Phase Induction Motor - Squirrel Cage

Customer : Dealers Industrial Equipment 800-469-3110
 Customer reference : 05018OT3E326T-W40

Product line : W40 NEMA Premium Efficiency Three-Phase Product code : 14367636
 Catalog # : 05018OT3E326T-W40

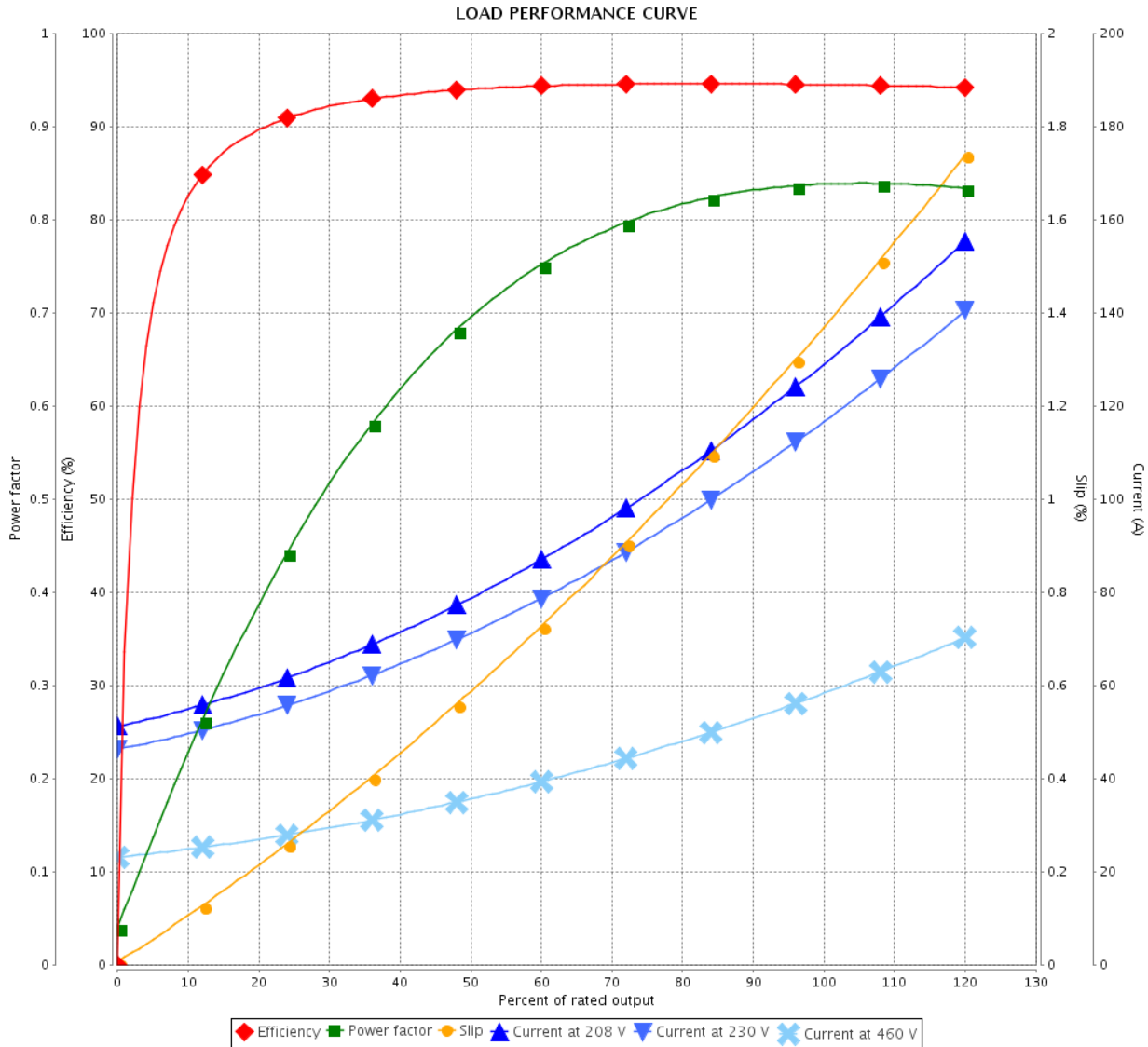

Performance : 208-230/460 V 60 Hz 4P

Rated current : 129-117/58.5 A	Moment of inertia (J) : 7.08 sq.ft.lb
LRC : 6.3	Duty cycle : Cont.(S1)
Rated torque : 146 ft.lb	Insulation class : F
Locked rotor torque : 240 %	Service factor : 1.25
Breakdown torque : 240 %	Temperature rise : 80 K
Rated speed : 1775 rpm	Design : B

Rev.	Changes Summary	Performed	Checked	Date
Performed by			Page	Revision
Checked by				
Date				

Dimensões em polegada
Dimensions in inches

THIS IS AN UPDATED REVISION, THE
PREVIOUS ONE MUST BE DISREGARDED.

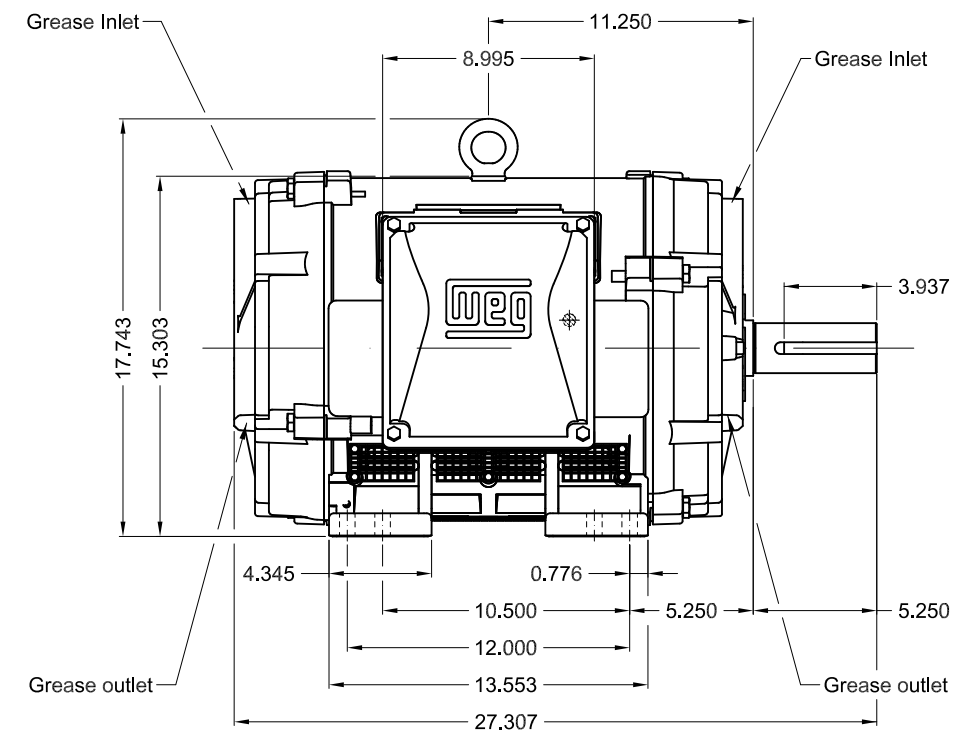
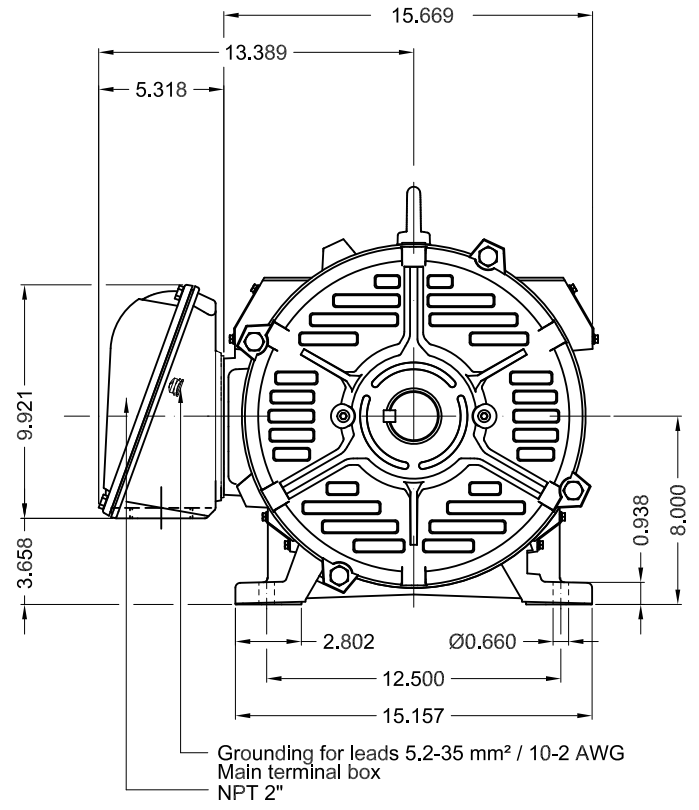

Color RAL 5009
Painting plan 203A
Mounting B3R(D)

					SCALE	1:8	
ECM	LOC	SUMMARY OF MODIFICATIONS	EXECUTED	CHECKED	RELEASED	DATE	VER
EXECUTED	USERADMIN	THREE PHASE W40 MOTOR NEMA PREMIUM EFF					
CHECKED		FRAME 324/6T IP23 ODP					
RELEASED		WEG code: 14367636					
REL DT	14.04.2019	WMO Jaragua do Sul	Product Engineering	SHEET	1 / 1		

50 HP 04 Poles 60Hz

A

