

# DATA SHEET



## Three Phase Induction Motor - Squirrel Cage

Customer : Dealers Industrial Equipment 800-469-3110					
Customer reference : 01518OT3E254T-W40					
Product line : W40 NEMA Premium Efficiency Three-Phase		Product code :	14366964		
		Catalog # :	01518OT3E254T-W40		
Frame : 254T	Locked rotor time : 30s (cold) 17s (hot)	Output : 15 HP (11 kW)	Temperature rise : 80 K	Poles : 4	
Frequency : 60 Hz	Duty cycle : Cont.(S1)	Rated voltage : 208-230/460 V	Ambient temperature : -20°C to +40°C	L. R. Amperes : 248-224/112 A	
Rated current : 38.7-35.0/17.5 A	Altitude : 1000 m.a.s.l.	L. R. Amperes : 248-224/112 A	Protection degree : IP23	LRC : 6.4x(Code G)	
No load current : 11.2-13.0/6.50 A	Cooling method : IC01 - ODP	Rated speed : 1770 rpm	Mounting : F-1	No load current : 11.2-13.0/6.50 A	
Slip : 1.67 %	Rotation <sup>1</sup> : Both (CW and CCW)	Rated torque : 43.9 ft.lb	Noise level <sup>2</sup> : 62.0 dB(A)	Rated torque : 43.9 ft.lb	
Locked rotor torque : 240 %	Starting method : Direct On Line	Breakdown torque : 280 %	Approx. weight <sup>3</sup> : 262 lb	Locked rotor torque : 240 %	
Insulation class : F		Insulation class : F		Insulation class : F	
Service factor : 1.25		Service factor : 1.25		Service factor : 1.25	
Moment of inertia (J) : 2.72 sq.ft.lb		Moment of inertia (J) : 2.72 sq.ft.lb		Moment of inertia (J) : 2.72 sq.ft.lb	
Design : B		Design : B		Design : B	
Output	25%	50%	75%	100%	
Efficiency (%)	91.0	91.7	92.4	93.0	
Power Factor	0.28	0.38	0.78	0.85	
Foundation loads					
Max. traction					
Max. compression					
		<u>Drive end</u>	<u>Non drive end</u>		
Bearing type :	6309 Z C3		6209 Z C3		
Sealing :	Without Bearing Seal		Without Bearing Seal		
Lubrication interval :	20000 h		20000 h		
Lubricant amount :	13 g		9 g		
Lubricant type :	Mobil Polyrex EM				
Notes downloaded from <a href="http://dealerselectric.com">http://dealerselectric.com</a>					
This revision replaces and cancel the previous one, which must be eliminated. (1) Looking the motor from the shaft end. (2) Measured at 1m and with tolerance of +3dB(A). (3) Approximate weight subject to changes after manufacturing process. (4) At 100% of full load.			These are average values based on tests with sinusoidal power supply, subject to the tolerances stipulated in NEMA MG-1.		
Rev.	Changes Summary		Performed	Checked	Date
Performed by					
Checked by				Page	Revision
Date	13/04/2019			1 / 2	

# LOAD PERFORMANCE CURVE



## Three Phase Induction Motor - Squirrel Cage

Customer : Dealers Industrial Equipment 800-469-3110  
 Customer reference : 01518OT3E254T-W40

Product line : W40 NEMA Premium Efficiency Three-Phase      Product code : 14366964  
 Catalog # : 01518OT3E254T-W40

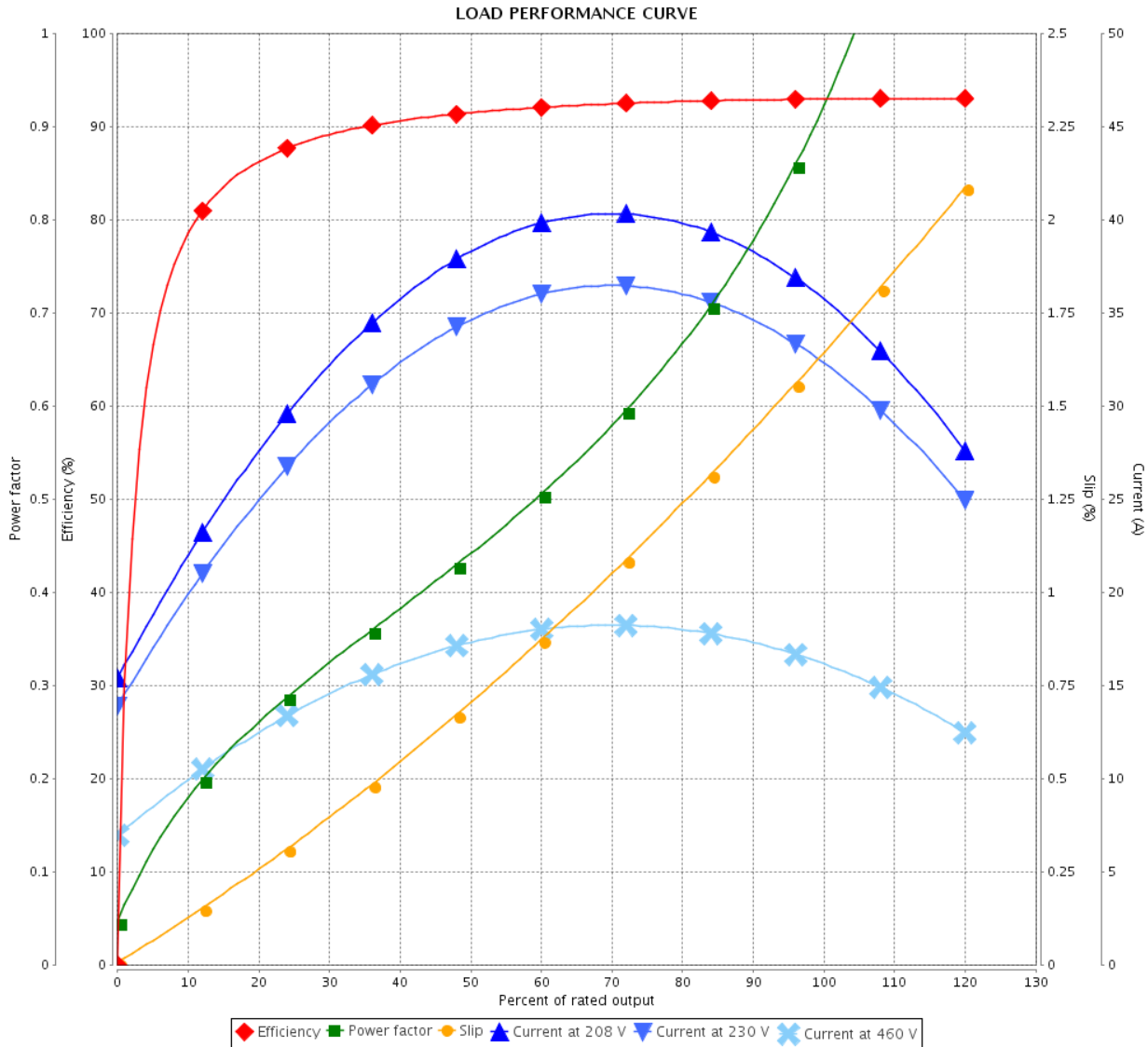

Performance : 208-230/460 V 60 Hz 4P

Rated current : 38.7-35.0/17.5 A	Moment of inertia (J) : 2.72 sq.ft.lb
LRC : 6.4	Duty cycle : Cont.(S1)
Rated torque : 43.9 ft.lb	Insulation class : F
Locked rotor torque : 240 %	Service factor : 1.25
Breakdown torque : 280 %	Temperature rise : 80 K
Rated speed : 1770 rpm	Design : B

Rev.	Changes Summary	Performed	Checked	Date
Performed by		Page		Revision
Checked by		2 / 2		
Date		13/04/2019		

Dimensões em polegada  
Dimensions in inches

THIS IS AN UPDATED REVISION, THE  
PREVIOUS ONE MUST BE DISREGARDED.

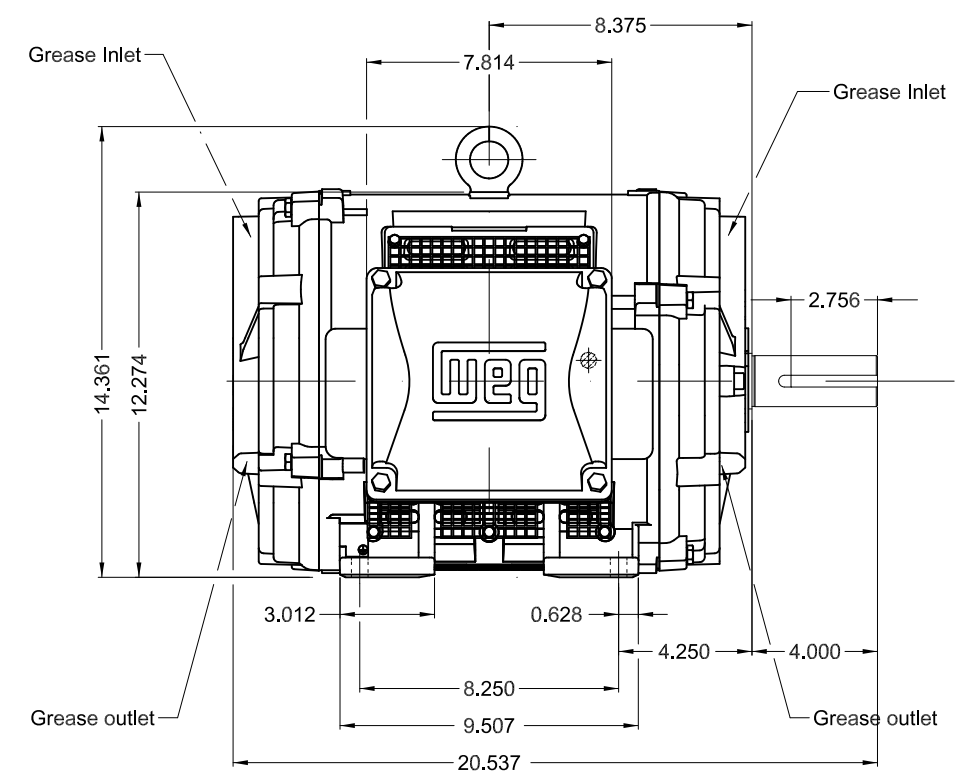
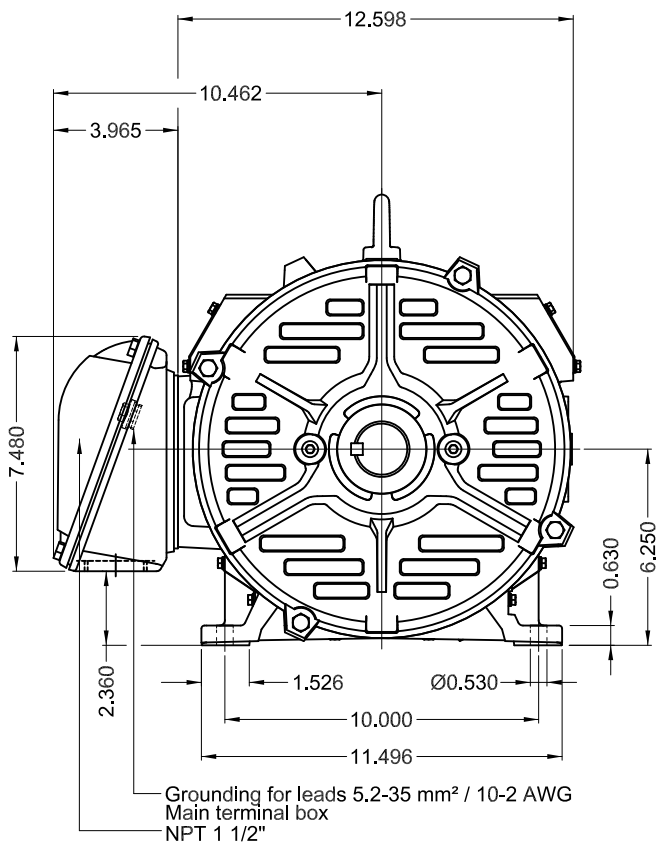

Color RAL 5009									
Painting plan 203A									
Mounting B3R(D)									
					SCALE	1:6			
ECM	LOC	SUMMARY OF MODIFICATIONS			EXECUTED	CHECKED	RELEASED	DATE	VER
EXECUTED	USERADMIN	THREE PHASE W40 MOTOR NEMA PREMIUM EFF							
CHECKED		FRAME 254T IP23 ODP							
RELEASED		WEG code: 14366964							
REL DT	13.04.2019	WMO	Jaragua do Sul	Product Engineering	SHEET	1 / 1			

15 HP 04 Poles 60Hz

A

