

DATA SHEET



Three Phase Induction Motor - Squirrel Cage

Customer	: Dealers Industrial Equipment 800-469-3110				
Customer reference	: 00318XT3H182JP				
Product line	: W21 Explosion-proof Motor NEMA Premium Efficiency Three-Phase		Product code :	14308685	
			Catalog # :	00318XT3H182JP	
Frame	: 182/4TZ		Locked rotor time	: 50s (cold) 28s (hot)	
Output	: 3 HP (2.2 kW)		Temperature rise	: 80 K	
Poles	: 4		Duty cycle	: Cont.(S1)	
Frequency	: 60 Hz		Ambient temperature	: -20°C to +40°C	
Rated voltage	: 575 V		Altitude	: 1000 m.a.s.l.	
Rated current	: 3.13 A		Protection degree	: IP55	
L. R. Amperes	: 25.0 A		Cooling method	: IC411 - TEFC	
LRC	: 8.0x(Code K)		Mounting	: F-1	
No load current	: 1.68 A		Rotation ¹	: Both (CW and CCW)	
Rated speed	: 1760 rpm		Noise level ²	: 56.0 dB(A)	
Slip	: 2.22 %		Starting method	: Direct On Line	
Rated torque	: 8.83 ft.lb		Approx. weight ³	: 124 lb	
Locked rotor torque	: 250 %				
Breakdown torque	: 320 %				
Insulation class	: F				
Service factor	: 1.15				
Moment of inertia (J)	: 0.2781 sq.ft.lb				
Design	: B				
Output	25%	50%	75%	100%	
Efficiency (%)	86.4	87.5	88.5	89.5	
Power Factor	0.35	0.59	0.71	0.79	
	Foundation loads				
			Max. traction	: 55 lb	
			Max. compression	: 111 lb	
		<u>Drive end</u>		<u>Non drive end</u>	
Bearing type	:	6307 2RS		6206 2RS	
Sealing	:	Oil Seal		Lip Seal	
Lubrication interval	:	-		-	
Lubricant amount	:	-		-	
Lubricant type	:	Mobil Polyrex EM			
Notes downloaded from http://dealerselectric.com					
This revision replaces and cancel the previous one, which must be eliminated. (1) Looking the motor from the shaft end. (2) Measured at 1m and with tolerance of +3dB(A). (3) Approximate weight subject to changes after manufacturing process. (4) At 100% of full load.			These are average values based on tests with sinusoidal power supply, subject to the tolerances stipulated in NEMA MG-1.		
Rev.	Changes Summary		Performed	Checked	Date
Performed by					
Checked by				Page	Revision
Date	12/04/2019			1 / 3	

DATA SHEET



Three Phase Induction Motor - Squirrel Cage

Customer : Dealers Industrial Equipment 800-469-3110
Customer reference : 00318XT3H182JP

Thermal protection

ID	Application	Type	Quantity	Sensing Temperature
1	Winding	Thermostat - 2 wires	1 x Phase	155 °C

Rev.	Changes Summary	Performed	Checked	Date
Performed by				
Checked by			Page	Revision
Date	12/04/2019		2 / 3	

LOAD PERFORMANCE CURVE



Three Phase Induction Motor - Squirrel Cage

Customer : Dealers Industrial Equipment 800-469-3110
 Customer reference : 00318XT3H182JP

Product line : W21 Explosion-proof Motor NEMA Premium Efficiency Three-Phase Product code : 14308685
 Catalog # : 00318XT3H182JP

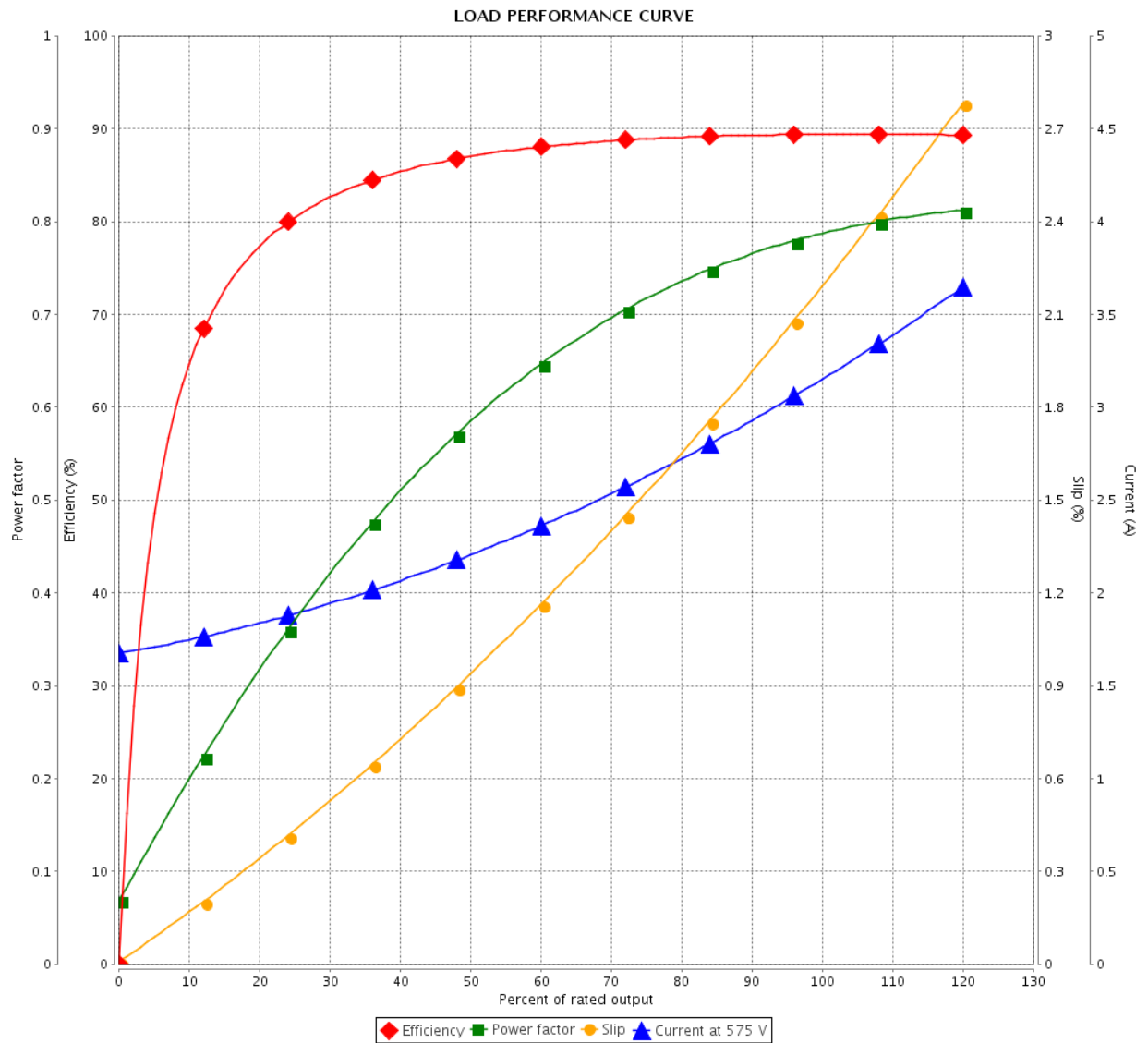

Performance : 575 V 60 Hz 4P

Rated current : 3.13 A
 LRC : 8.0
 Rated torque : 8.83 ft.lb
 Locked rotor torque : 250 %
 Breakdown torque : 320 %
 Rated speed : 1760 rpm

Moment of inertia (J) : 0.2781 sq.ft.lb
 Duty cycle : Cont.(S1)
 Insulation class : F
 Service factor : 1.15
 Temperature rise : 80 K
 Design : B

Rev.	Changes Summary	Performed	Checked	Date
Performed by		Page		Revision
Checked by		3 / 3		
Date	12/04/2019			

EIXO/SHAFT	
PADRÃO/STANDARD	
OPCIONAL/OPTIONAL	
ESPECIAL/SPECIAL	X

Dimensões em polegada
Dimensions in inches

CERTIFIED WEG MOTORES
Certified document.
Not subject to changes.

THIS IS AN UPDATED REVISION, THE PREVIOUS ONE MUST BE DISREGARDED.

A
B
C
D
E

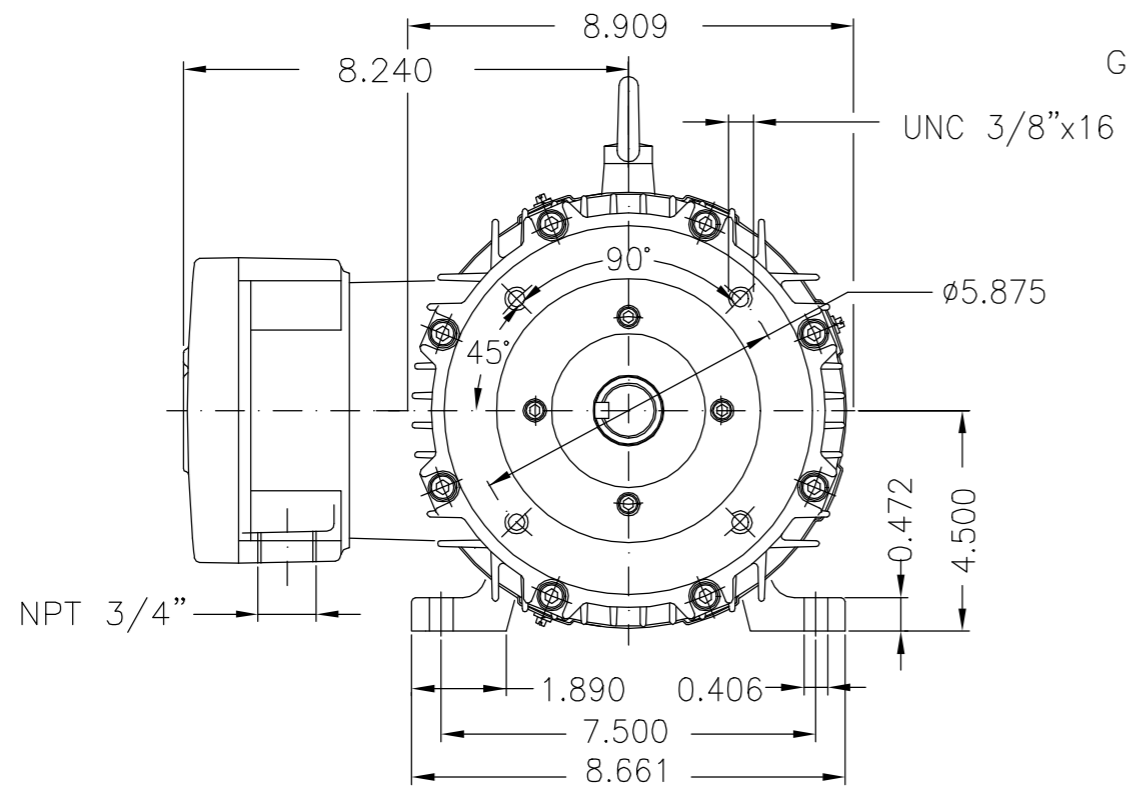

Grounding for leads 2-10 mm² / 14-7 AWG

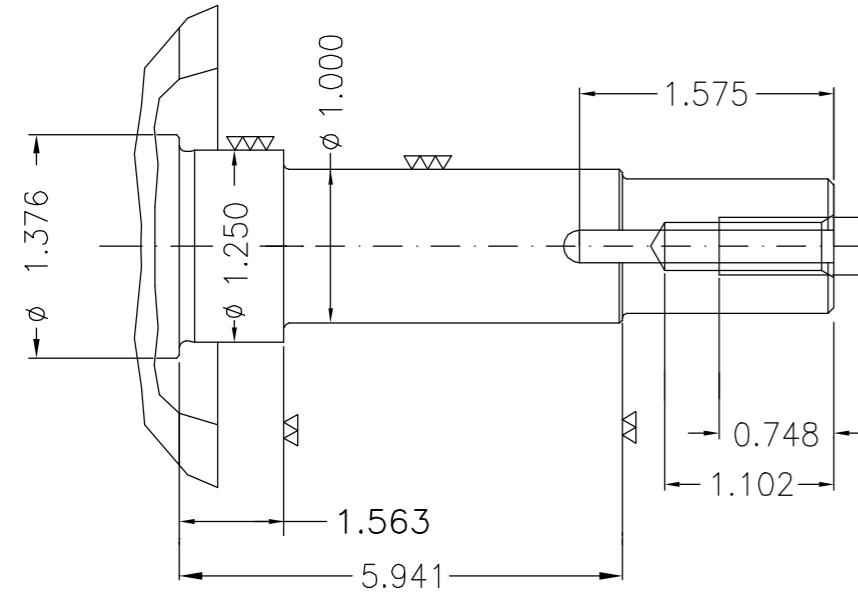
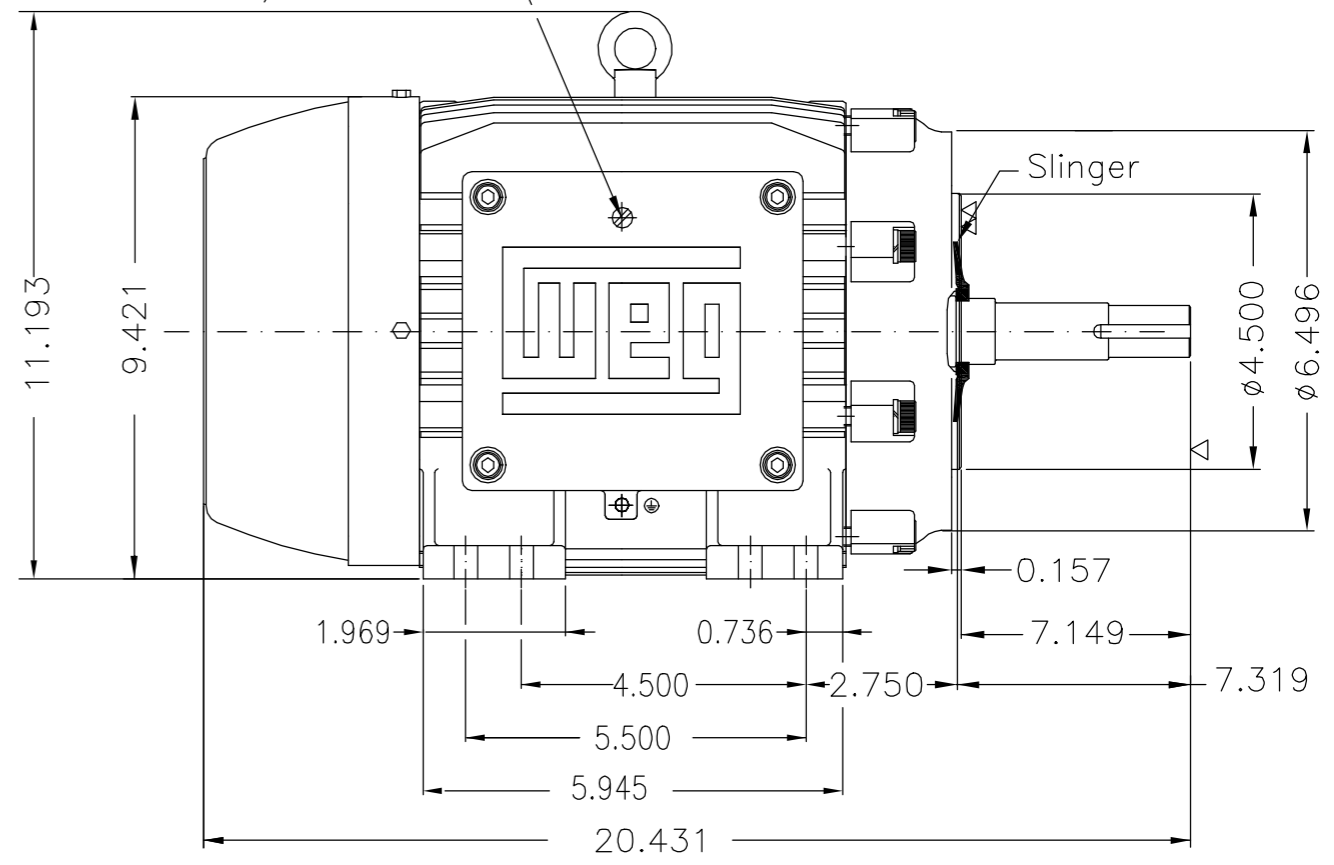

DE Shaft End

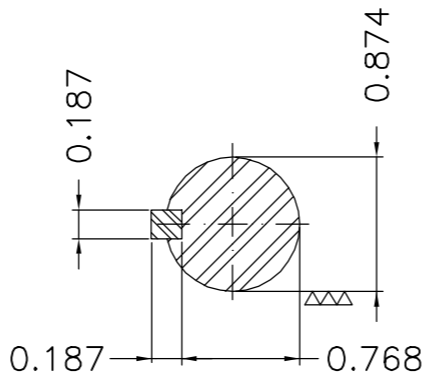

EUNC 3/8"-16 WEG TBG253

Ponta de eixo JP / JP shaft end						
Tampa flangeada especial / Special flanged endshield						
Cor RAL 5009 / Color RAL 5009						
Plano de pintura 202P / Painting plan 202P						
Forma construtiva NEMA F-1 / Mounting NEMA F-1						
Forma construtiva B34D / Mounting B34R(D)						
WEG ELECTRIC CORPORATION - WEG						

500001501926		Corrigido representação dos pés	JAMORIM	DALTONR	DALTONR	13.09.2018	04		
500001500307	C-3	CORRIGIDO COTA "AH"	NSCHMIDT	RAFAELVARGAS	RAFAELVARGAS	11.09.2018	03		
ECM	LOC	SUMMARY OF MODIFICATIONS	EXECUTED	CHECKED	RELEASED	DATE	VER		
EXECUTED	NSCHMIDT	THREE PHASE EXPL. PROOF MOTOR NEMA P.EFF FRAME 182/4TZ IP55 TEFC	10005520452						
CHECKED	FERNANDOLUIS							000	04
RELEASED	FERNANDOLUIS							SHEET	01 / 2
REL DT	07.02.2018	WMO	Jaragua do Sul	Product Engineering					

3 HP 04 Poles 60Hz 414947131/0

A

UNCONTROLLED COPY

RELEASED

ZME A3