

DATA SHEET



Three Phase Induction Motor - Squirrel Cage

Customer : Dealers Industrial Equipment 800-469-3110
 Customer reference : 12518OT3G405TSC-W40

Product line : W40 NEMA Premium Efficiency Three-Phase Product code : 14284974
 Catalog # : 12518OT3G405TSC-W40

Frame	: 404/5TSC	Locked rotor time	: 18s (cold) 10s (hot)
Output	: 125 HP	Temperature rise	: 80 K
Poles	: 4	Duty cycle	: Cont.(S1)
Frequency	: 60 Hz	Ambient temperature	: -20°C to +40°C
Rated voltage	: 460 V	Altitude	: 1000 m.a.s.l.
Rated current	: 138 A	Protection degree	: IP23
L. R. Amperes	: 952 A	Cooling method	: IC01 - ODP
LRC	: 6.9x(Code G)	Mounting	: F-1
No load current	: 47.0 A	Rotation ¹	: Both (CW and CCW)
Rated speed	: 1780 rpm	Noise level ²	: 69.0 dB(A)
Slip	: 1.11 %	Starting method	: Direct On Line
Rated torque	: 364 ft.lb	Approx. weight ³	: 1037 lb
Locked rotor torque	: 270 %		
Breakdown torque	: 260 %		
Insulation class	: F		
Service factor	: 1.25		
Moment of inertia (J)	: 25.5 sq.ft.lb		
Design	: B		

Output	25%	50%	75%	100%	Foundation loads	
Efficiency (%)	94.9	95.0	95.4	95.4	Max. traction	: 2886 lb
Power Factor	0.50	0.75	0.83	0.86	Max. compression	: 3924 lb

		<u>Drive end</u>	<u>Non drive end</u>
Bearing type	:	6314 C3	6212 Z C3
Sealing	:	Without Bearing Seal	Without Bearing Seal
Lubrication interval	:	20000 h	20000 h
Lubricant amount	:	27 g	13 g
Lubricant type	:	Mobil Polyrex EM	

Notes
 downloaded from <http://dealerselectric.com>

This revision replaces and cancel the previous one, which must be eliminated.
 (1) Looking the motor from the shaft end.
 (2) Measured at 1m and with tolerance of +3dB(A).
 (3) Approximate weight subject to changes after manufacturing process.
 (4) At 100% of full load.

These are average values based on tests with sinusoidal power supply, subject to the tolerances stipulated in NEMA MG-1.

Rev.	Changes Summary		Performed	Checked	Date
Performed by					
Checked by				Page	Revision
Date	15/04/2019			1 / 2	

LOAD PERFORMANCE CURVE



Three Phase Induction Motor - Squirrel Cage

Customer : Dealers Industrial Equipment 800-469-3110
 Customer reference : 12518OT3G405TSC-W40

Product line : W40 NEMA Premium Efficiency Three-Phase Product code : 14284974
 Catalog # : 12518OT3G405TSC-W40

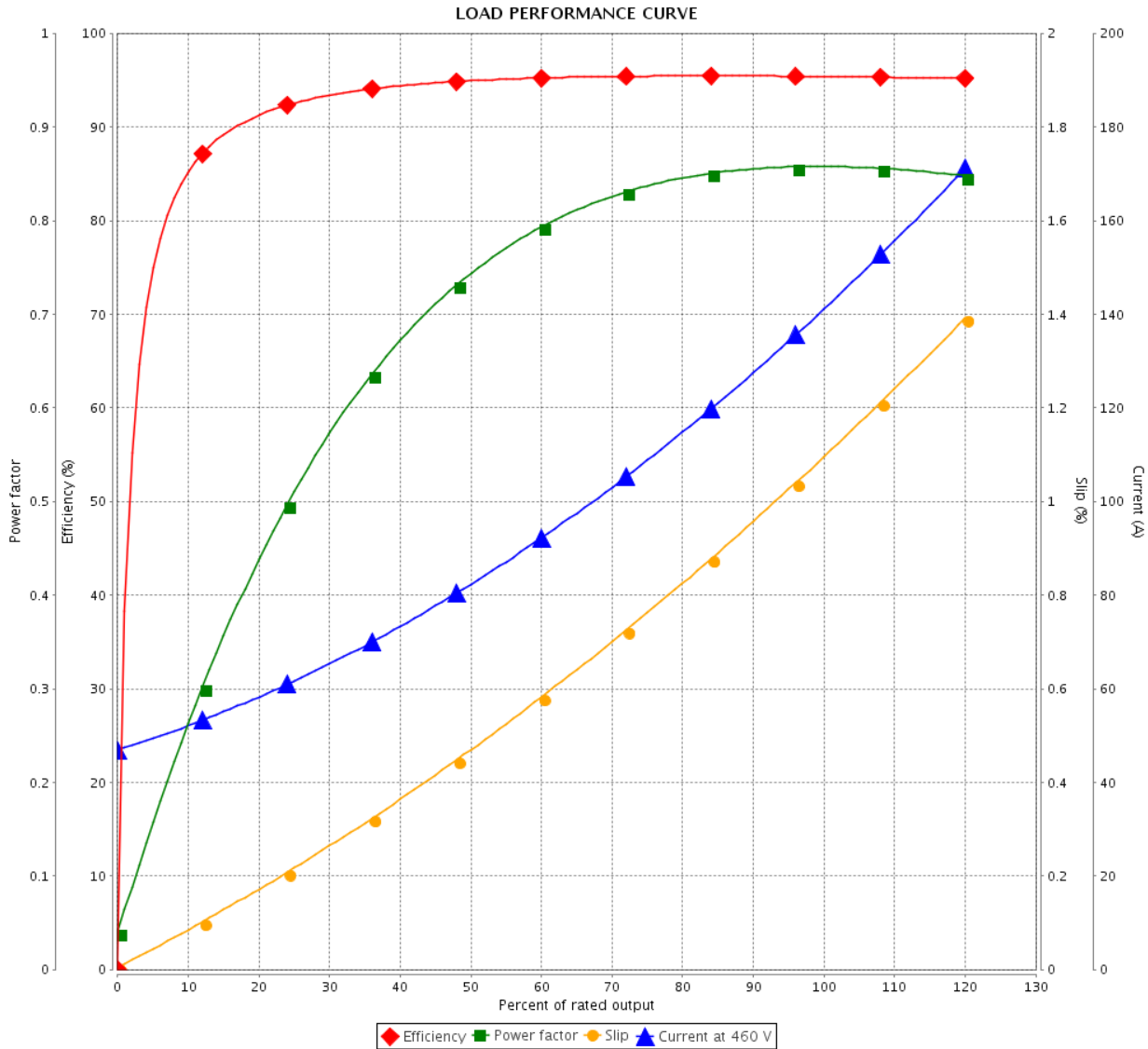

Performance : 460 V 60 Hz 4P

Rated current : 138 A	Moment of inertia (J) : 25.5 sq.ft.lb
LRC : 6.9	Duty cycle : Cont.(S1)
Rated torque : 364 ft.lb	Insulation class : F
Locked rotor torque : 270 %	Service factor : 1.25
Breakdown torque : 260 %	Temperature rise : 80 K
Rated speed : 1780 rpm	Design : B

Rev.	Changes Summary	Performed	Checked	Date
Performed by			Page	Revision
Checked by			2 / 2	
Date	15/04/2019			

Dimensões em polegada
Dimensions in inches

THIS IS AN UPDATED REVISION, THE
PREVIOUS ONE MUST BE DISREGARDED.

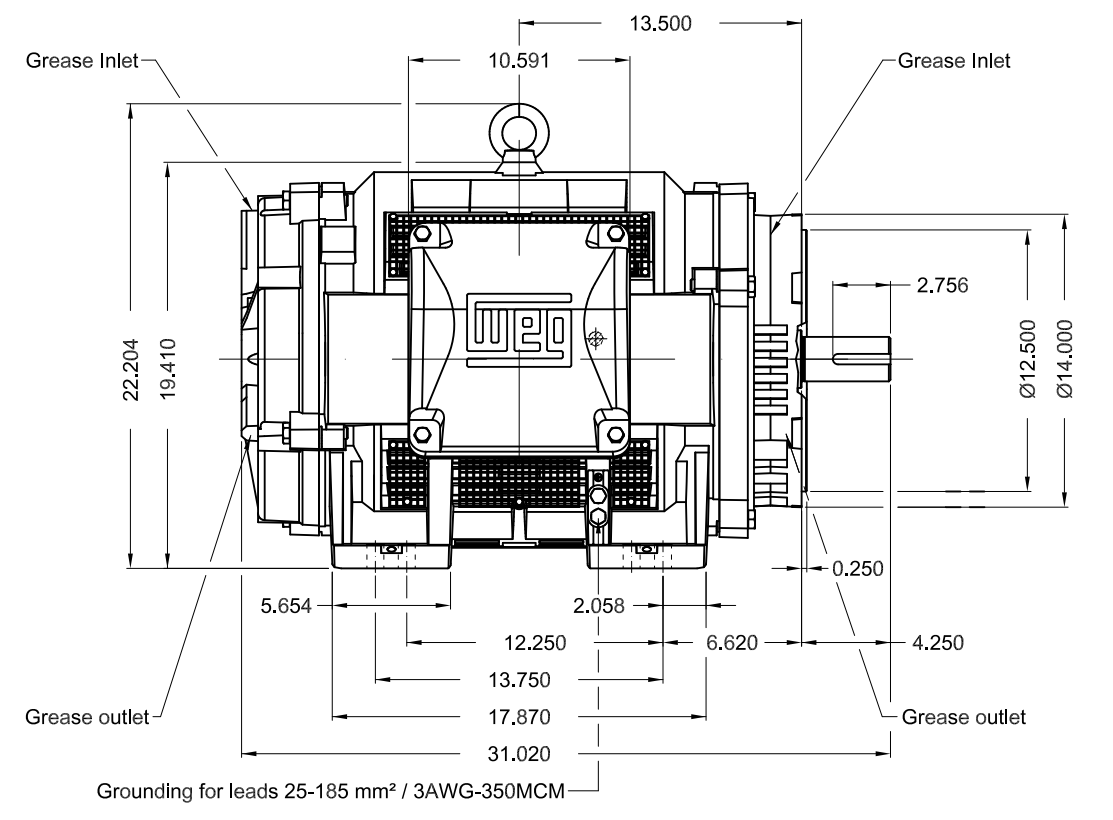
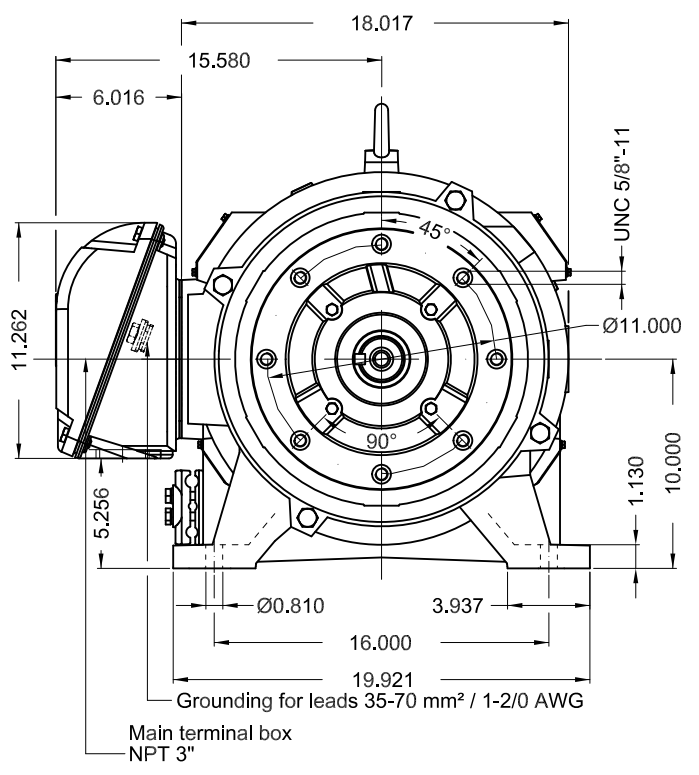

TS shaft end						
Shaft material – SAE/ABNT 1040/45						
Color RAL 5009						
Painting plan 203A						
Mounting B34R(D)						
					SCALE	1:9
ECM	LOC	SUMMARY OF MODIFICATIONS			EXECUTED	CHECKED
EXECUTED	USERADMIN	THREE PHASE W40 MOTOR NEMA PREMIUM EFF				
CHECKED		FRAME 404/5TSC IP23 ODP				
RELEASED		WEG code: 14284974				
REL DT	15.04.2019	WMO	Jaragua do Sul	Product Engineering	SHEET	1 / 1

125 HP 04 Poles 60Hz

A

