



# LOAD PERFORMANCE CURVE



## Three Phase Induction Motor - Squirrel Cage

Customer : Dealers Industrial Equipment 800-469-3110  
 Customer reference : 20018OP3GFP445TS-W40

Product line : W40 High Efficiency Three-Phase      Product code : 14282856  
 Catalog # : 20018OP3GFP445TS-W40

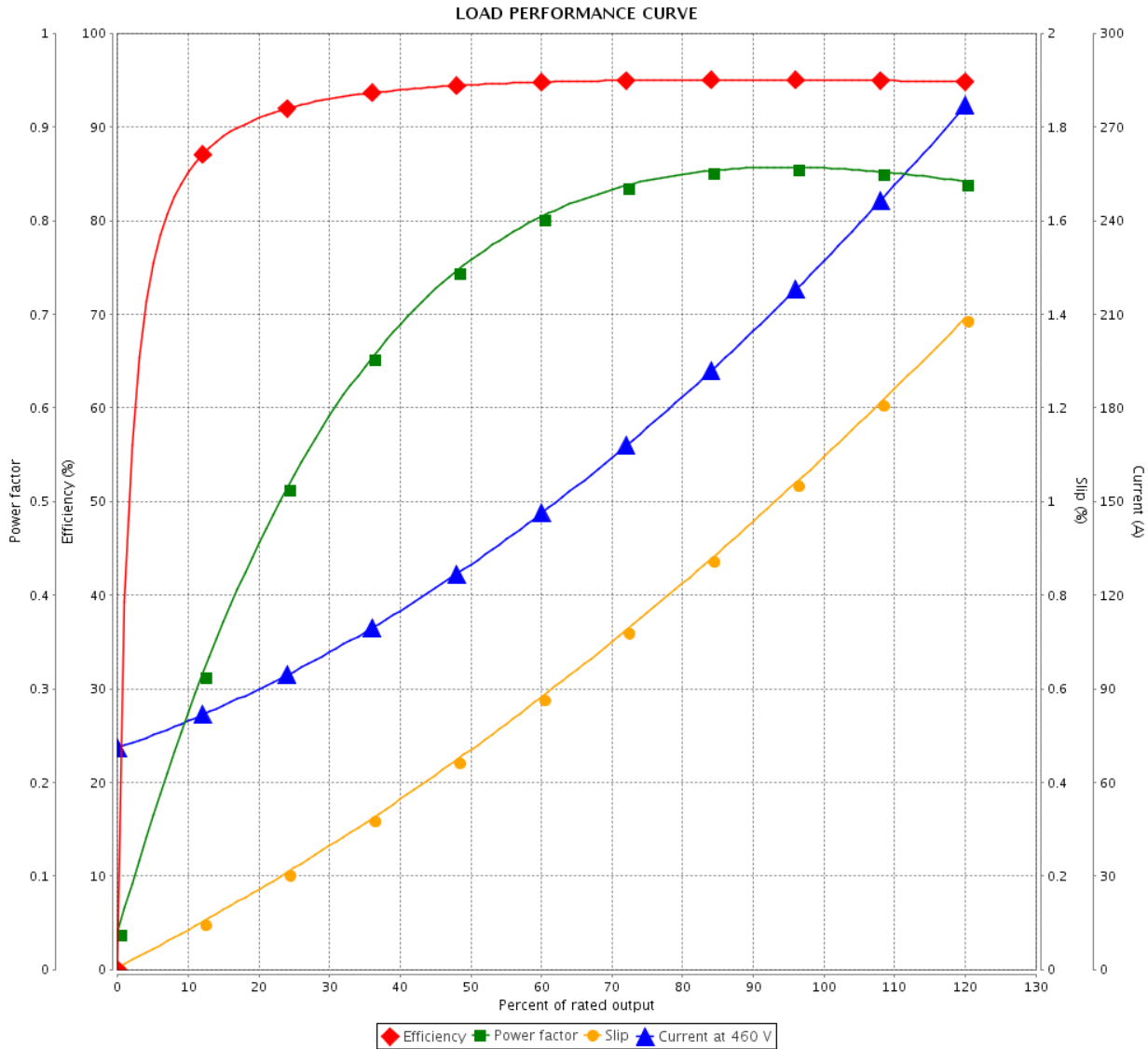

Performance : 460 V 60 Hz 4P

Rated current : 230 A	Moment of inertia (J) : 42.3 sq.ft.lb
LRC : 6.2	Duty cycle : Cont.(S1)
Rated torque : 582 ft.lb	Insulation class : F
Locked rotor torque : 180 %	Service factor : 1.15
Breakdown torque : 210 %	Temperature rise : 105 K
Rated speed : 1780 rpm	Design : B

Rev.	Changes Summary	Performed	Checked	Date
Performed by			Page	Revision
Checked by			2 / 2	
Date	16/04/2019			

Dimensões em polegada  
Dimensions in inches

THIS IS AN UPDATED REVISION, THE  
PREVIOUS ONE MUST BE DISREGARDED.

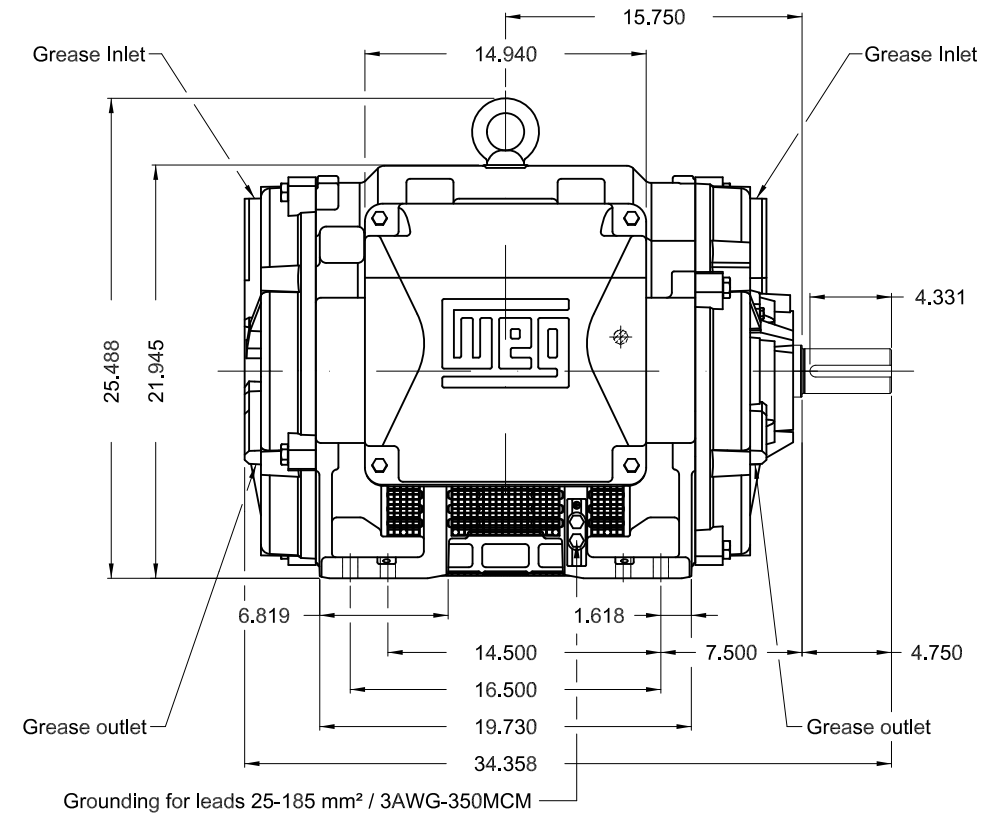
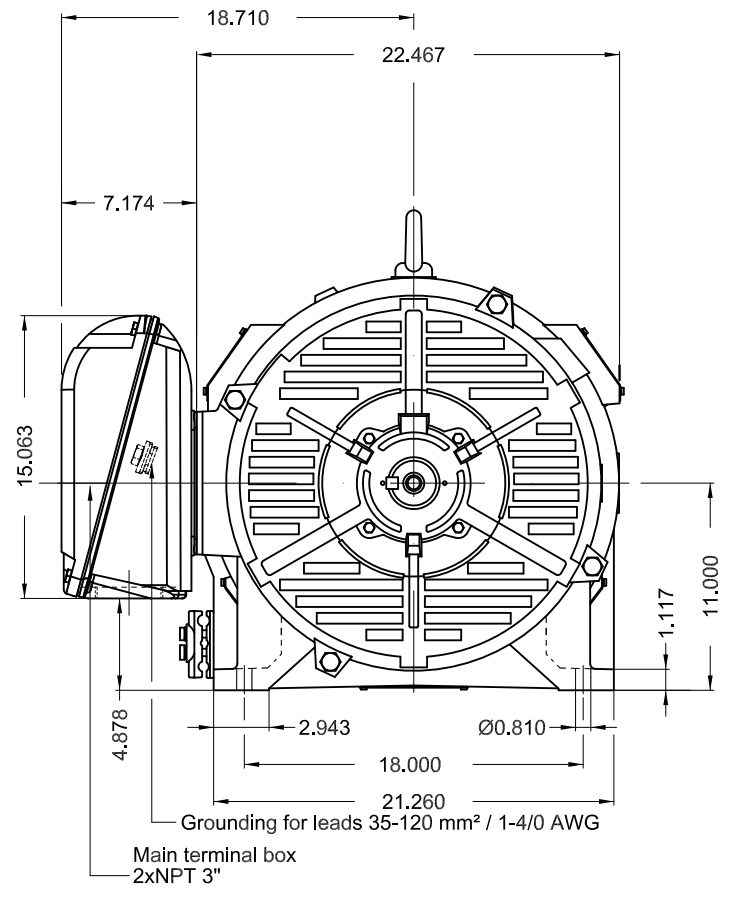

TS shaft end						
Shaft material – SAE/ABNT 1040/45						
Color RAL 3002						
Painting plan 203A						
Mounting B3R(D)						
					SCALE	1:10
ECM	LOC	SUMMARY OF MODIFICATIONS			EXECUTED	CHECKED
EXECUTED	USERADMIN	THREE PHASE W40 MOTOR HIGH EFF				
CHECKED		FRAME 444/5TS IP23 ODP				
RELEASED		WEG code: 14282856				
REL DT	16.04.2019	WMO	Jaragua do Sul	Product Engineering	SHEET	1 / 1

200 HP 04 Poles 60Hz

A

