

DATA SHEET



Three Phase Induction Motor - Squirrel Cage

Customer	: Dealers Industrial Equipment 800-469-3110				
Customer reference	: 12518OP3GFP405TC-W40				
Product line	: W40 High Efficiency Three-Phase		Product code :	14282560	
			Catalog # :	12518OP3GFP405TC-W40	
Frame	: 404/5TC		Locked rotor time	: 21s (cold) 12s (hot)	
Output	: 125 HP		Temperature rise	: 105 K	
Poles	: 4		Duty cycle	: Cont.(S1)	
Frequency	: 60 Hz		Ambient temperature	: -20°C to +40°C	
Rated voltage	: 460 V		Altitude	: 1000 m.a.s.l.	
Rated current	: 139 A		Protection degree	: IP23	
L. R. Amperes	: 904 A		Cooling method	: IC01 - ODP	
LRC	: 6.5x(Code G)		Mounting	: F-1	
No load current	: 38.0 A		Rotation ¹	: Both (CW and CCW)	
Rated speed	: 1775 rpm		Starting method	: Direct On Line	
Slip	: 1.39 %		Approx. weight ³	: 983 lb	
Rated torque	: 365 ft.lb				
Locked rotor torque	: 210 %				
Breakdown torque	: 229 %				
Insulation class	: F				
Service factor	: 1.15				
Moment of inertia (J)	: 21.5 sq.ft.lb				
Design	: B				
Output	25%	50%	75%	100%	
Efficiency (%)	94.0	94.1	94.5	94.5	
Power Factor	0.54	0.76	0.84	0.86	
	Foundation loads				
	Max. traction : 2588 lb				
	Max. compression : 3572 lb				
	<u>Drive end</u>		<u>Non drive end</u>		
Bearing type	: 6316 C3		: 6212 Z C3		
Sealing	: Without Bearing Seal		: Without Bearing Seal		
Lubrication interval	: 20000 h		: 20000 h		
Lubricant amount	: 34 g		: 13 g		
Lubricant type	: Mobil Polyrex EM				
Notes downloaded from http://dealerselectric.com					
This revision replaces and cancel the previous one, which must be eliminated. (1) Looking the motor from the shaft end. (2) Measured at 1m and with tolerance of +3dB(A). (3) Approximate weight subject to changes after manufacturing process. (4) At 100% of full load.			These are average values based on tests with sinusoidal power supply, subject to the tolerances stipulated in NEMA MG-1.		
Rev.	Changes Summary		Performed	Checked	Date
Performed by					
Checked by				Page	Revision
Date	15/04/2019			1 / 2	

LOAD PERFORMANCE CURVE



Three Phase Induction Motor - Squirrel Cage

Customer : Dealers Industrial Equipment 800-469-3110
 Customer reference : 12518OP3GFP405TC-W40

Product line : W40 High Efficiency Three-Phase Product code : 14282560
 Catalog # : 12518OP3GFP405TC-W40

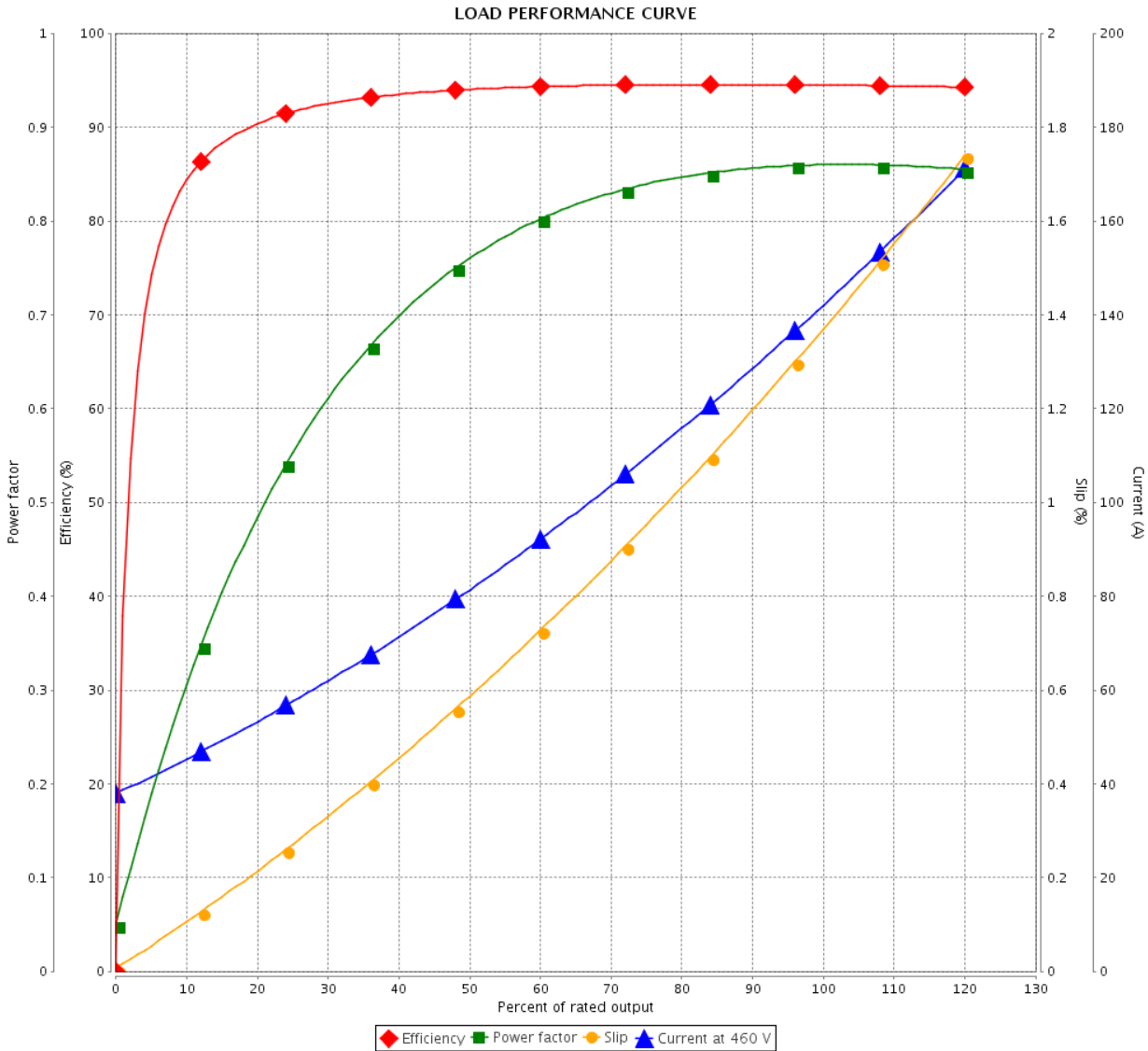

Performance : 460 V 60 Hz 4P

Rated current : 139 A	Moment of inertia (J) : 21.5 sq.ft.lb
LRC : 6.5	Duty cycle : Cont.(S1)
Rated torque : 365 ft.lb	Insulation class : F
Locked rotor torque : 210 %	Service factor : 1.15
Breakdown torque : 229 %	Temperature rise : 105 K
Rated speed : 1775 rpm	Design : B

Rev.	Changes Summary	Performed	Checked	Date
Performed by			Page	Revision
Checked by				
Date				

Dimensões em polegada
Dimensions in inches

THIS IS AN UPDATED REVISION, THE
PREVIOUS ONE MUST BE DISREGARDED.

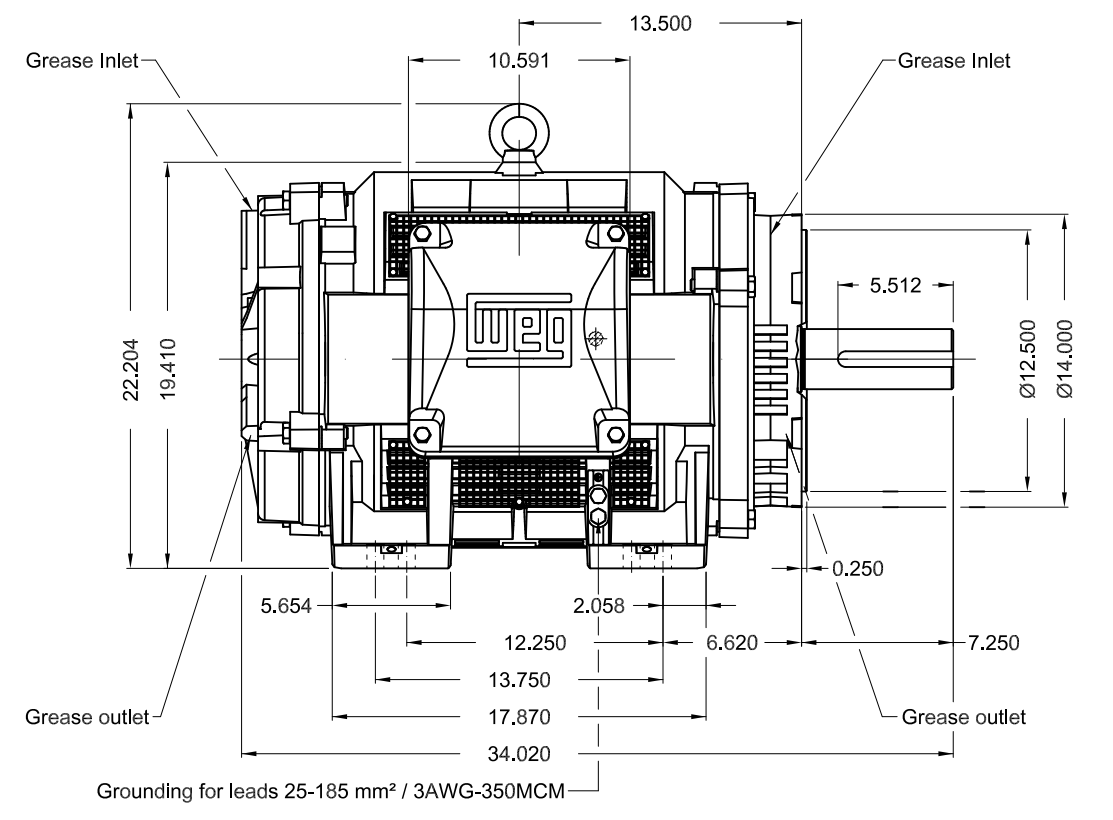
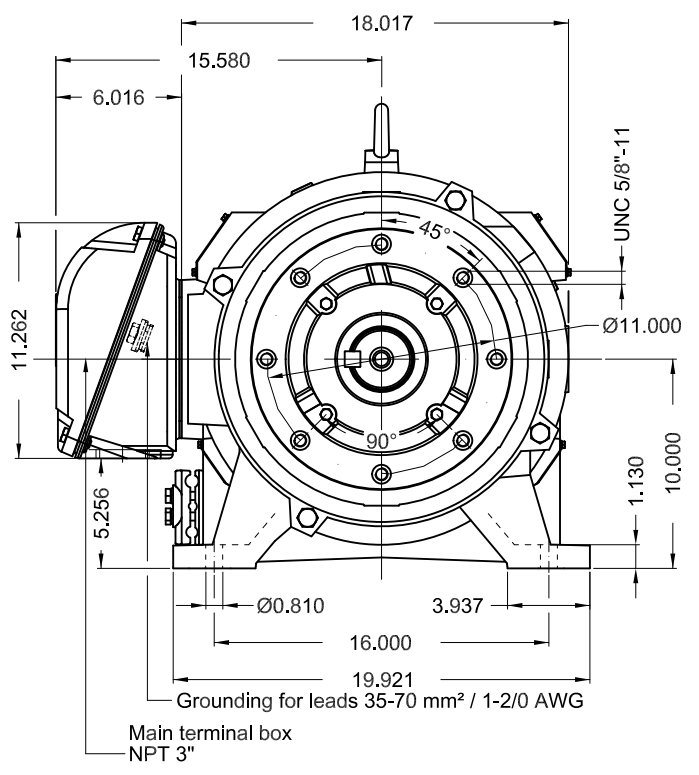

Color RAL 3002										
Painting plan 203A										
Mounting B34R(D)										
								SCALE	1:9	
ECM	LOC	SUMMARY OF MODIFICATIONS				EXECUTED	CHECKED	RELEASED	DATE	VER
EXECUTED	USERADMIN	THREE PHASE W40 MOTOR HIGH EFF								
CHECKED		FRAME 404/5TC IP23 ODP								
RELEASED		WEG code: 14282560								
REL DT	15.04.2019	WMO	Jaragua do Sul	Product Engineering	SHEET	1 / 1				

125 HP 04 Poles 60Hz

A

