

LOAD PERFORMANCE CURVE



Three Phase Induction Motor - Squirrel Cage

Customer : Dealers Industrial Equipment 800-469-3110
 Customer reference : 10018OP3HFP404TC-W40

Product line : W40 High Efficiency Three-Phase Product code : 14282265
 Catalog # : 10018OP3HFP404TC-W40

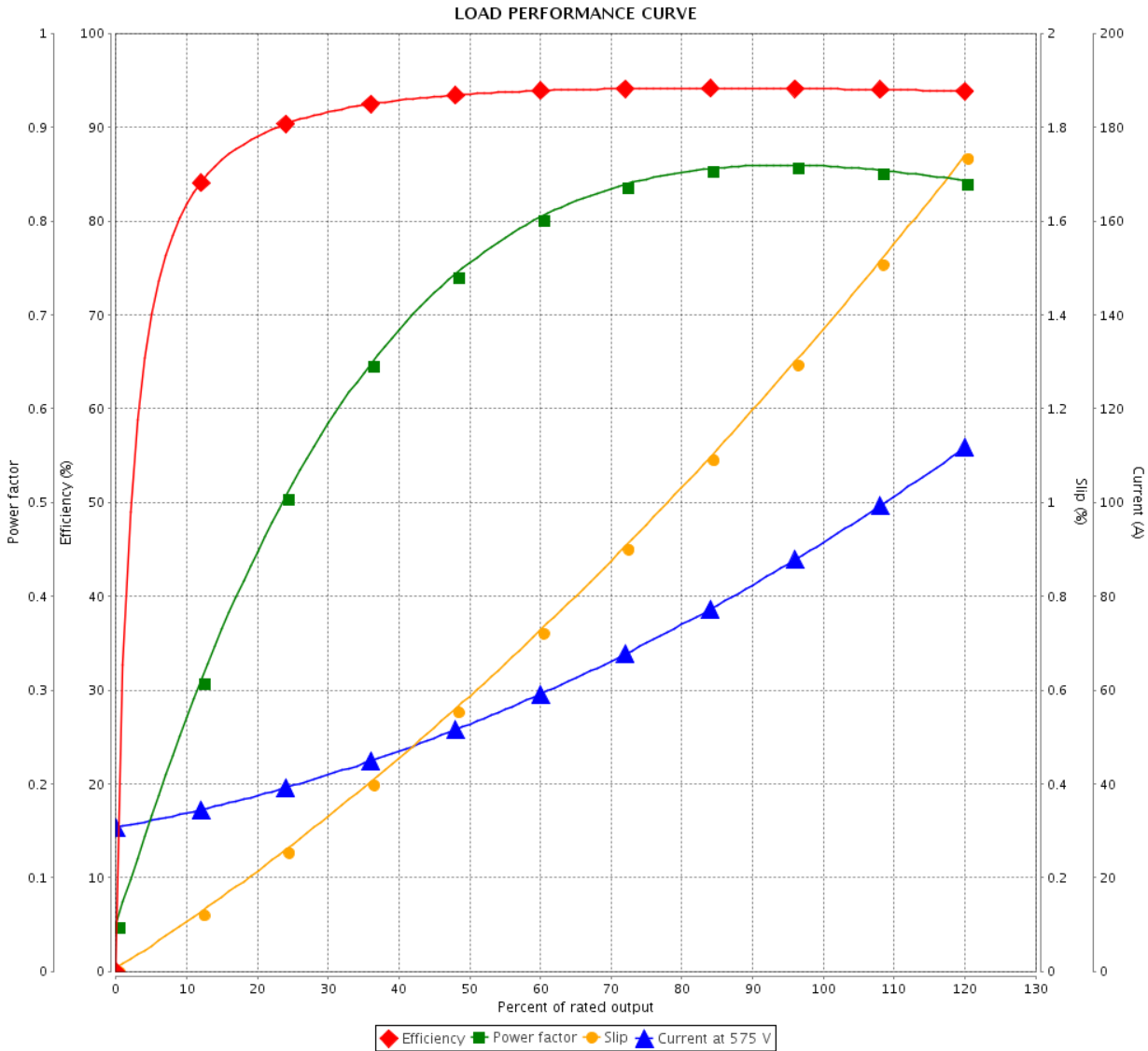

Performance : 575 V 60 Hz 4P

Rated current : 92.8 A	Moment of inertia (J) : 17.5 sq.ft.lb
LRC : 6.2	Duty cycle : Cont.(S1)
Rated torque : 292 ft.lb	Insulation class : F
Locked rotor torque : 220 %	Service factor : 1.15
Breakdown torque : 250 %	Temperature rise : 80 K
Rated speed : 1775 rpm	Design : B

Rev.	Changes Summary	Performed	Checked	Date
Performed by			Page	Revision
Checked by			2 / 2	
Date	14/04/2019			

Dimensões em polegada
Dimensions in inches

THIS IS AN UPDATED REVISION, THE
PREVIOUS ONE MUST BE DISREGARDED.

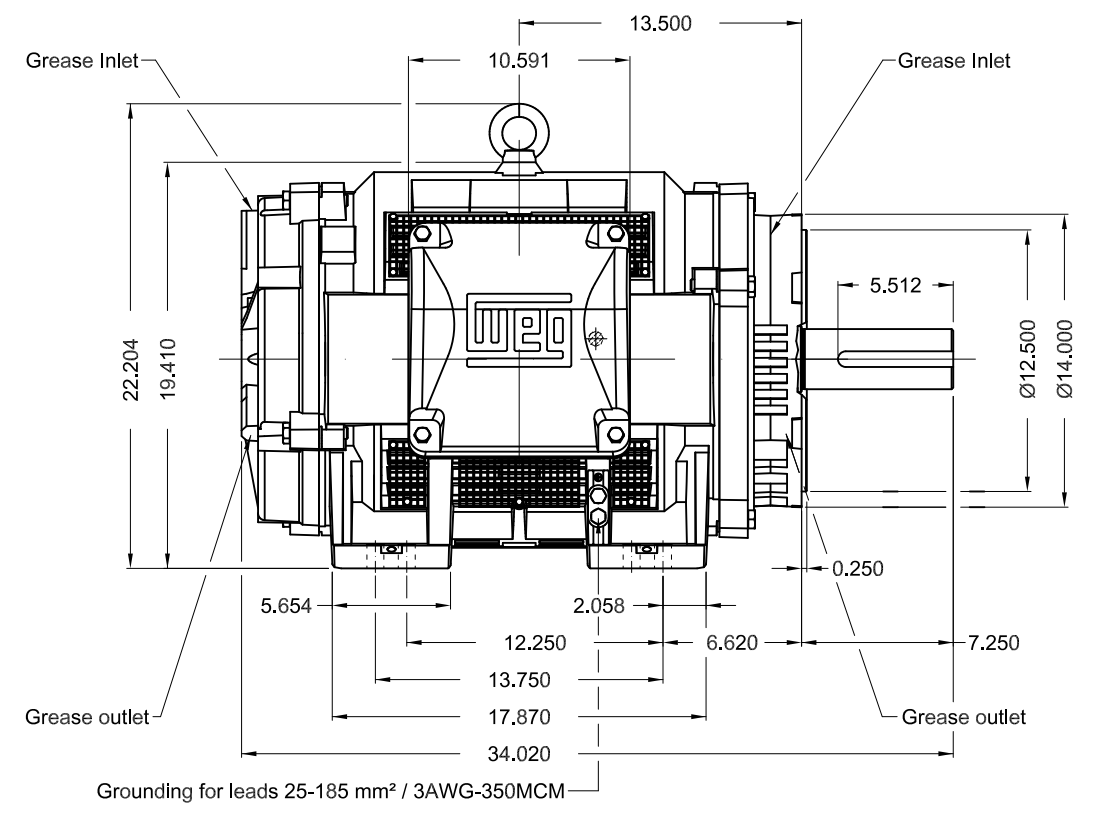
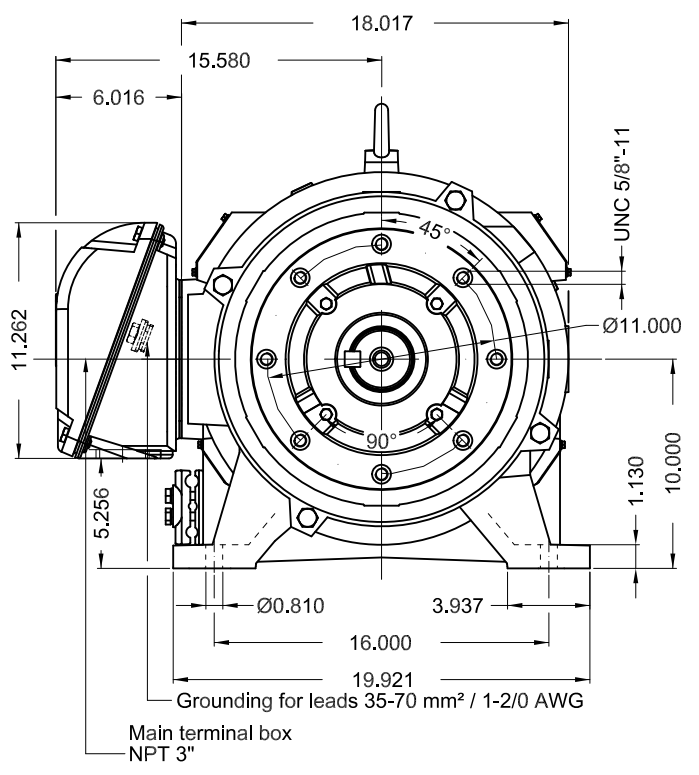

Color RAL 3002						
Painting plan 203A						
Mounting B34R(D)						
					SCALE	1:9
ECM	LOC	SUMMARY OF MODIFICATIONS			EXECUTED	CHECKED
EXECUTED	USERADMIN	THREE PHASE W40 MOTOR HIGH EFF				
CHECKED		FRAME 404/5TC IP23 ODP				
RELEASED		WEG code: 14282265				
REL DT	14.04.2019	WMO	Jaragua do Sul	Product Engineering	SHEET	1 / 1

100 HP 04 Poles 60Hz

A

