

# DATA SHEET



## Three Phase Induction Motor - Squirrel Cage

Customer : Dealers Industrial Equipment 800-469-3110  
 Customer reference : 07536OP3JFP364TS-W40

Product line : W40 High Efficiency Three-Phase      Product code : 14281360  
 Catalog # : 07536OP3JFP364TS-W40

Frame	: 364/5TS	Locked rotor time	: 46s (cold) 26s (hot)
Output	: 75 HP (55 kW)	Temperature rise	: 105 K
Poles	: 2	Duty cycle	: Cont.(S1)
Frequency	: 60 Hz	Ambient temperature	: -20°C to +40°C
Rated voltage	: 380 V	Altitude	: 1000 m.a.s.l.
Rated current	: 103 A	Protection degree	: IP23
L. R. Amperes	: 599 A	Cooling method	: IC01 - ODP
LRC	: 5.8x(Code F)	Mounting	: F-1
No load current	: 30.5 A	Rotation <sup>1</sup>	: Both (CW and CCW)
Rated speed	: 3555 rpm	Starting method	: Direct On Line
Slip	: 1.25 %	Approx. weight <sup>3</sup>	: 662 lb
Rated torque	: 109 ft.lb		
Locked rotor torque	: 160 %		
Breakdown torque	: 210 %		
Insulation class	: F		
Service factor	: 1.15		
Moment of inertia (J)	: 5.60 sq.ft.lb		
Design	: B		

Output	25%	50%	75%	100%	Foundation loads	
Efficiency (%)	90.3	91.0	92.4	93.0	Max. traction	: 466 lb
Power Factor	0.55	0.80	0.85	0.87	Max. compression	: 1128 lb

	Drive end	Non drive end
Bearing type	: 6314 C3	6212 Z C3
Sealing	: Without Bearing Seal	Without Bearing Seal
Lubrication interval	: 14418 h	20000 h
Lubricant amount	: 27 g	13 g
Lubricant type	: Mobil Polyrex EM	

Notes  
 downloaded from <http://dealerselectric.com>

This revision replaces and cancel the previous one, which must be eliminated.  
 (1) Looking the motor from the shaft end.  
 (2) Measured at 1m and with tolerance of +3dB(A).  
 (3) Approximate weight subject to changes after manufacturing process.  
 (4) At 100% of full load.

These are average values based on tests with sinusoidal power supply, subject to the tolerances stipulated in NEMA MG-1.

Rev.	Changes Summary	Performed	Checked	Date
Performed by		Page		Revision
Checked by		1 / 2		
Date	14/04/2019			

# LOAD PERFORMANCE CURVE



## Three Phase Induction Motor - Squirrel Cage

Customer : Dealers Industrial Equipment 800-469-3110  
 Customer reference : 07536OP3JFP364TS-W40

Product line : W40 High Efficiency Three-Phase      Product code : 14281360  
 Catalog # : 07536OP3JFP364TS-W40

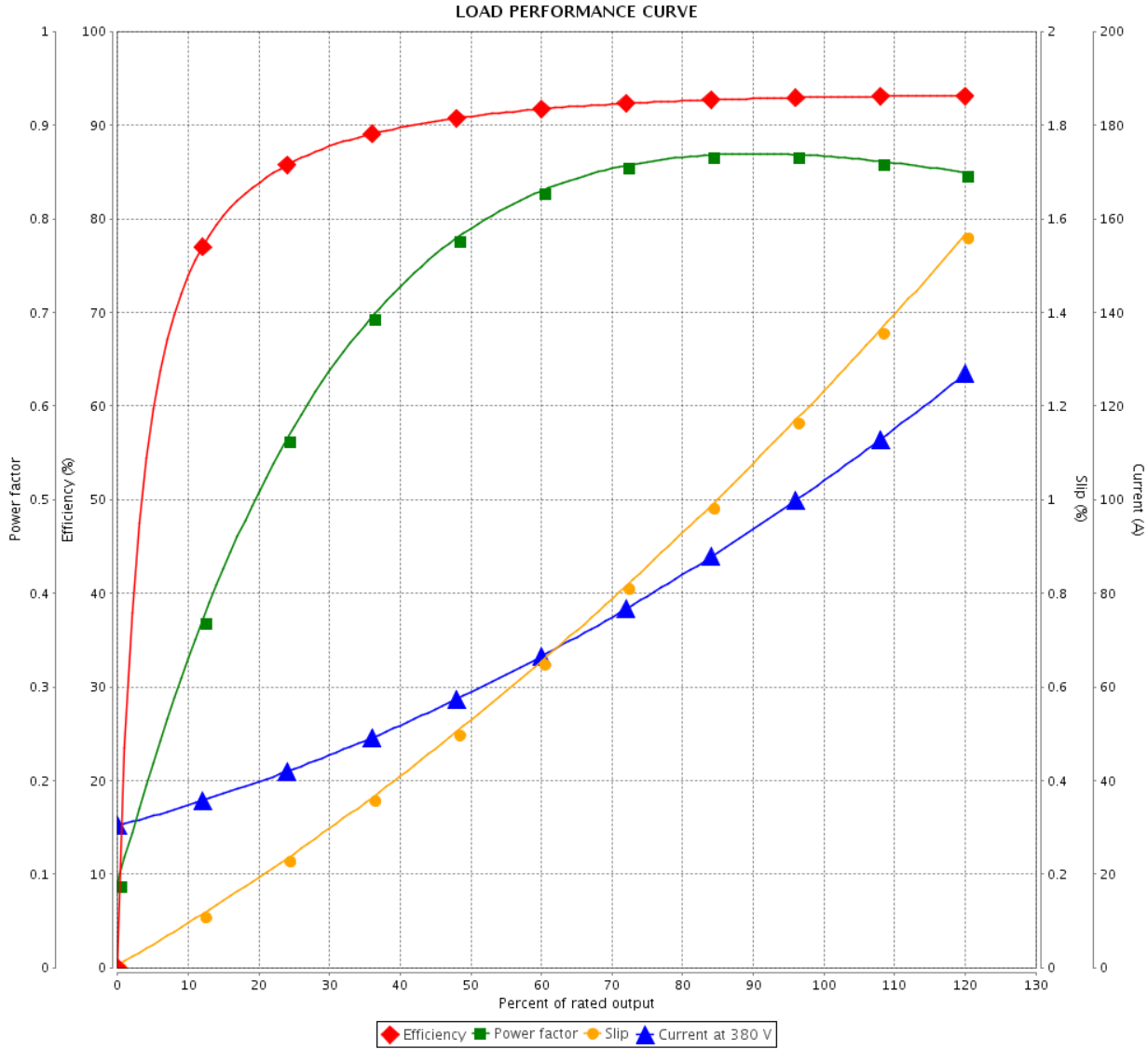

Performance : 380 V 60 Hz 2P

Rated current : 103 A	Moment of inertia (J) : 5.60 sq.ft.lb
LRC : 5.8	Duty cycle : Cont.(S1)
Rated torque : 109 ft.lb	Insulation class : F
Locked rotor torque : 160 %	Service factor : 1.15
Breakdown torque : 210 %	Temperature rise : 105 K
Rated speed : 3555 rpm	Design : B

Rev.	Changes Summary	Performed	Checked	Date
Performed by			Page 2 / 2	Revision
Checked by				
Date	14/04/2019			

Dimensões em polegada  
Dimensions in inches

THIS IS AN UPDATED REVISION, THE  
PREVIOUS ONE MUST BE DISREGARDED.

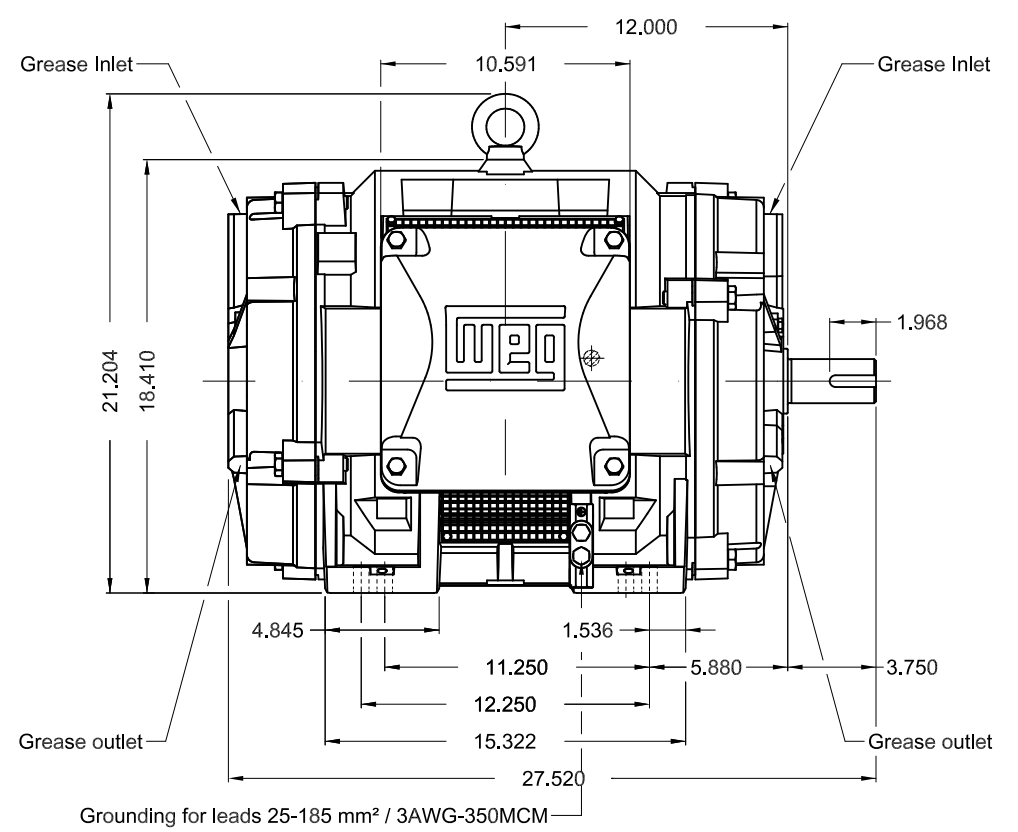
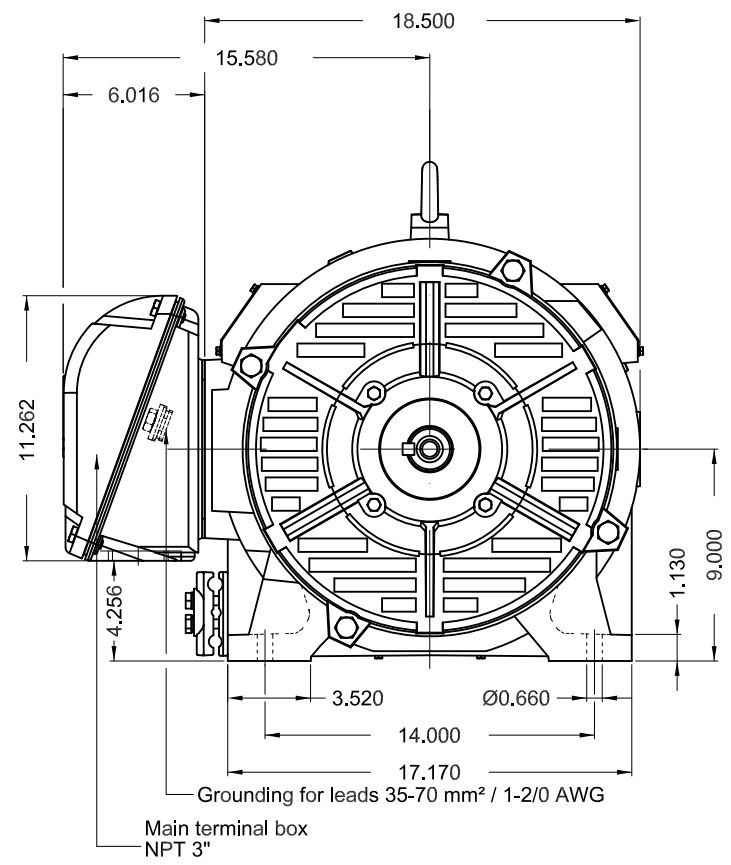

Color RAL 3002									
Painting plan 203A									
Mounting B3R(D)									
					SCALE	1:8			
ECM	LOC	SUMMARY OF MODIFICATIONS			EXECUTED	CHECKED	RELEASED	DATE	VER
EXECUTED	USERADMIN	THREE PHASE W40 MOTOR HIGH EFF							
CHECKED		FRAME 364/5TS IP23 ODP							
RELEASED		WEG code: 14281360							
REL DT	14.04.2019	WMO	Jaragua do Sul	Product Engineering	SHEET	1 / 1			

75 HP 02 Poles 60Hz

A

