

LOAD PERFORMANCE CURVE



Three Phase Induction Motor - Squirrel Cage

Customer : Dealers Industrial Equipment 800-469-3110
 Customer reference : 12518OT3G405T-W40

Product line : W40 NEMA Premium Efficiency Three-Phase Product code : 14272880
 Catalog # : 12518OT3G405T-W40

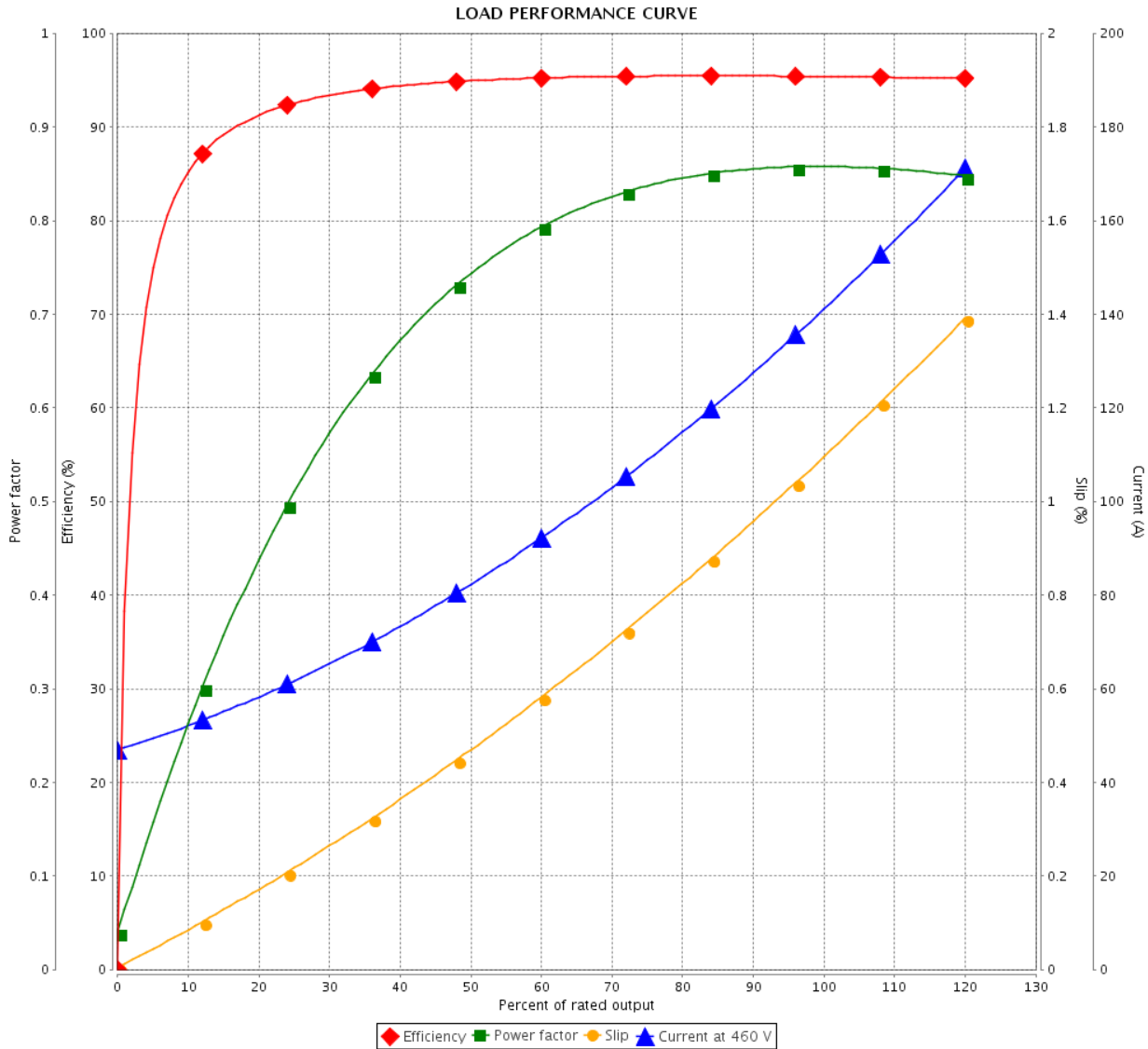

Performance : 460 V 60 Hz 4P

Rated current : 138 A	Moment of inertia (J) : 25.5 sq.ft.lb
LRC : 6.9	Duty cycle : Cont.(S1)
Rated torque : 364 ft.lb	Insulation class : F
Locked rotor torque : 270 %	Service factor : 1.25
Breakdown torque : 260 %	Temperature rise : 80 K
Rated speed : 1780 rpm	Design : B

Rev.	Changes Summary	Performed	Checked	Date
Performed by			Page 2 / 2	Revision
Checked by				
Date	15/04/2019			

Dimensões em polegada
Dimensions in inches

THIS IS AN UPDATED REVISION, THE
PREVIOUS ONE MUST BE DISREGARDED.

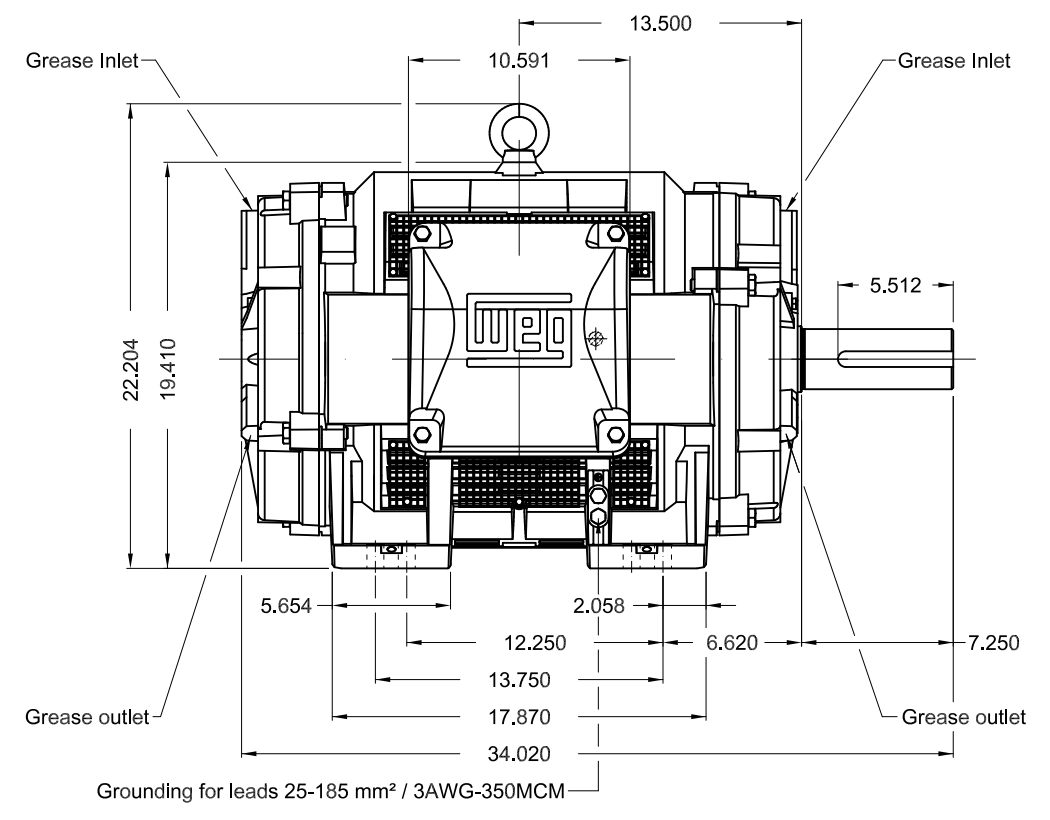
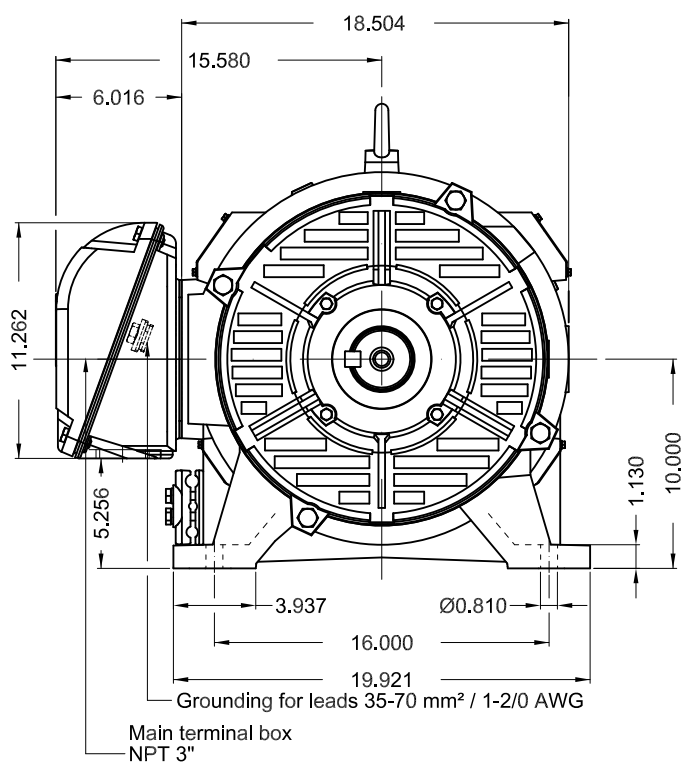

Color RAL 5009									
Painting plan 203A									
Mounting B3R(D)									
					SCALE	1:9			
ECM	LOC	SUMMARY OF MODIFICATIONS			EXECUTED	CHECKED	RELEASED	DATE	VER
EXECUTED	USERADMIN	THREE PHASE W40 MOTOR NEMA PREMIUM EFF							
CHECKED		FRAME 404/5T IP23 ODP							
RELEASED		WEG code: 14272880							
REL DT	15.04.2019	WMO	Jaragua do Sul	Product Engineering	SHEET	1 / 1			

125 HP 04 Poles 60Hz

A

