



# LOAD PERFORMANCE CURVE



## Three Phase Induction Motor - Squirrel Cage

Customer : Dealers Industrial Equipment 800-469-3110  
 Customer reference : 20018OT3G445T-W40

Product line : W40 NEMA Premium Efficiency Three-Phase      Product code : 14272546  
 Catalog # : 20018OT3G445T-W40

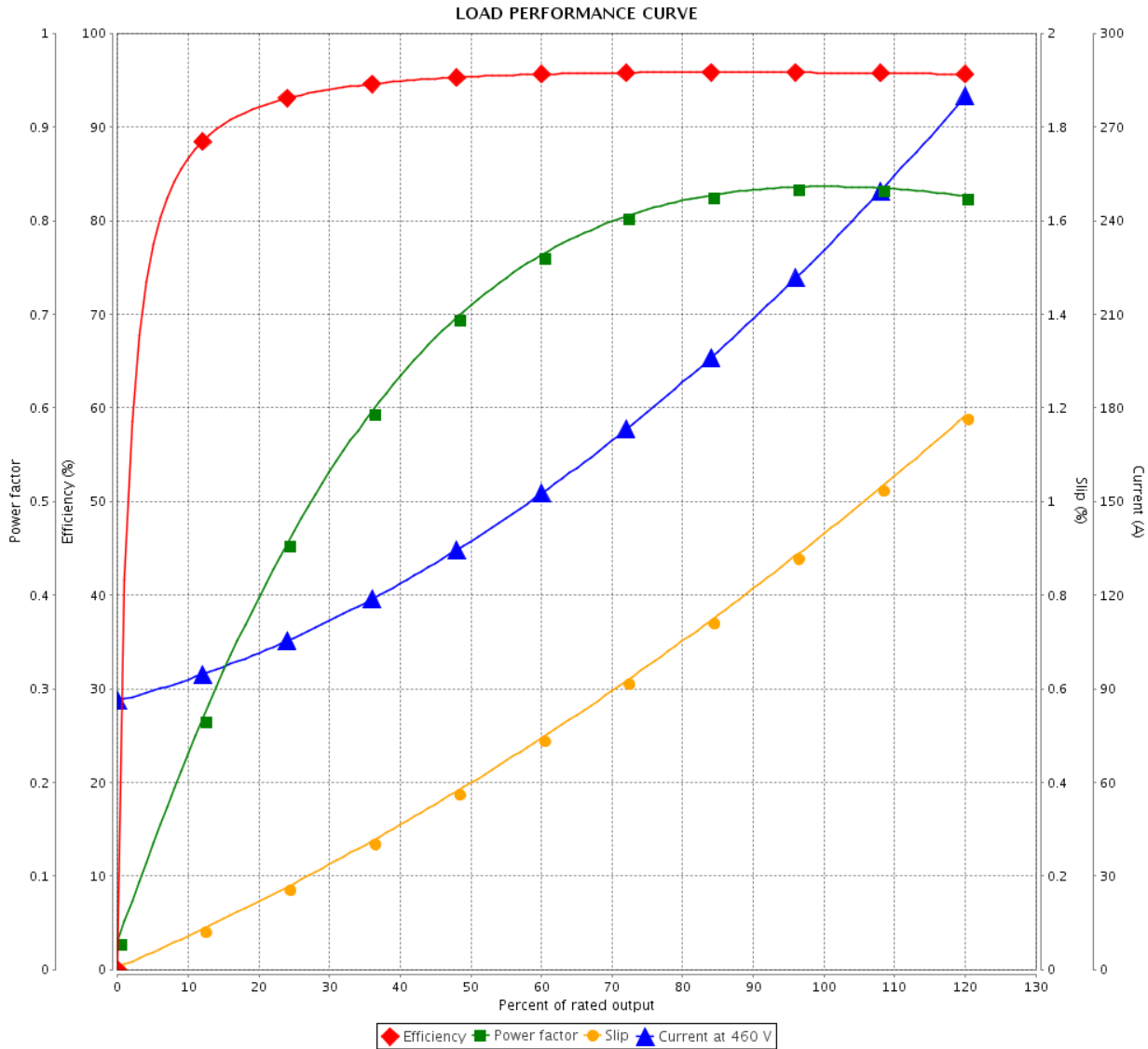

Performance	: 460 V 60 Hz 4P		
Rated current	: 234 A	Moment of inertia (J)	: 46.4 sq.ft.lb
LRC	: 6.6	Duty cycle	: Cont.(S1)
Rated torque	: 581 ft.lb	Insulation class	: F
Locked rotor torque	: 210 %	Service factor	: 1.15
Breakdown torque	: 250 %	Temperature rise	: 80 K
Rated speed	: 1783 rpm	Design	: B

Rev.	Changes Summary	Performed	Checked	Date
Performed by			Page 2 / 2	Revision
Checked by				
Date	16/04/2019			

Dimensões em polegada  
Dimensions in inches

THIS IS AN UPDATED REVISION, THE  
PREVIOUS ONE MUST BE DISREGARDED.

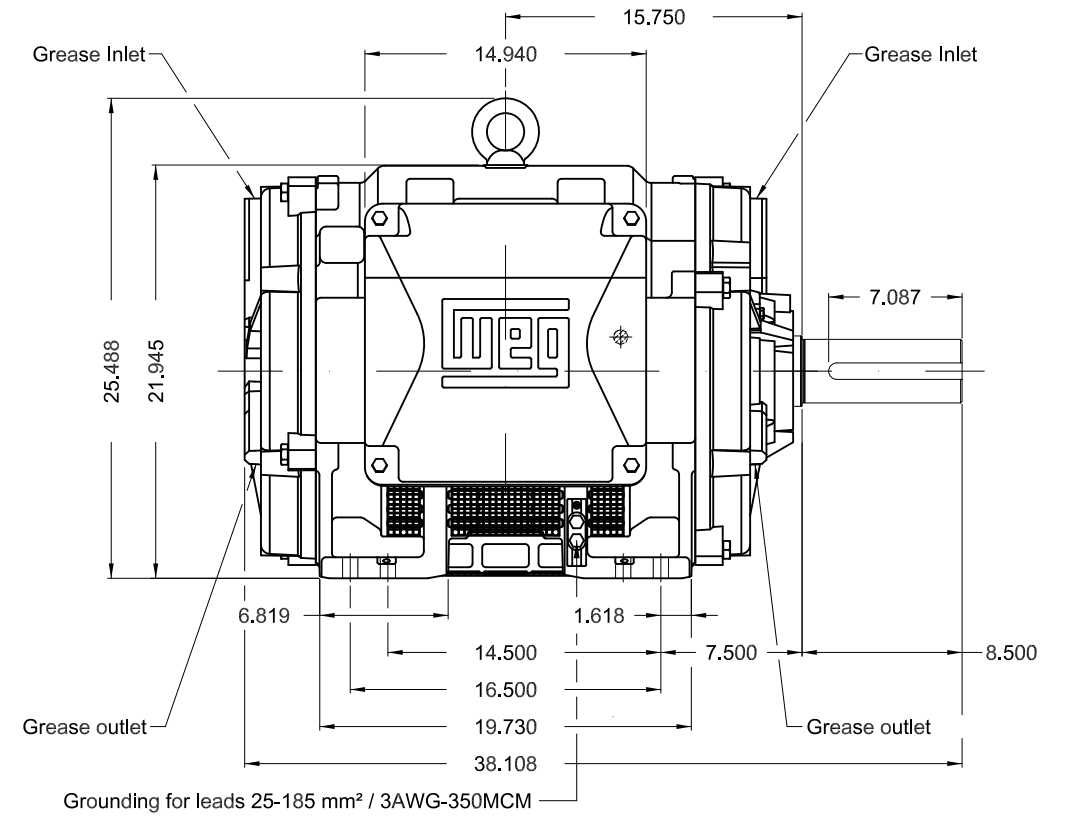
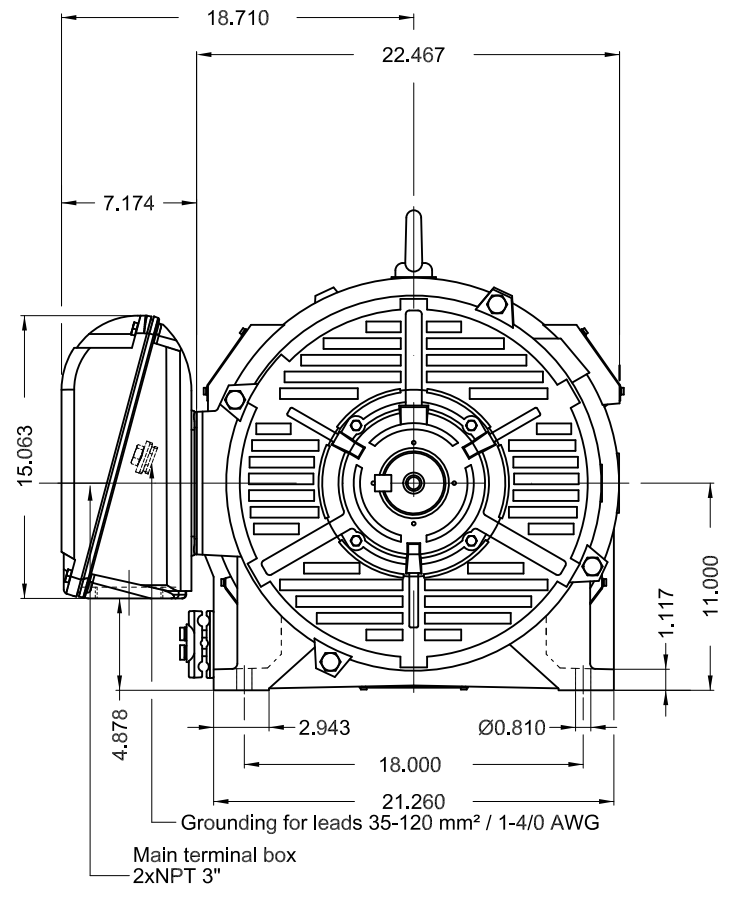

C3 NDE bearing						SCALE		1:10		
Color RAL 5009										
Painting plan 203A										
Mounting B3R(D)										
ECM		LOC		SUMMARY OF MODIFICATIONS		EXECUTED	CHECKED	RELEASED	DATE	VER
EXECUTED		USERADMIN		THREE PHASE W40 MOTOR NEMA PREMIUM EFF						
CHECKED				FRAME 444/5T IP23 ODP						
RELEASED				WEG code: 14272546						
REL DT		16.04.2019		WMO Jaragua do Sul		Product Engineering	SHEET	1 / 1		

200 HP 04 Poles 60Hz

A

