

DATA SHEET



Three Phase Induction Motor - Squirrel Cage

Customer	: Dealers Industrial Equipment 800-469-3110				
Customer reference	: 15018OT3H444TC-W40				
Product line	: W40 NEMA Premium Efficiency Three-Phase		Product code :	14272542	
			Catalog # :	15018OT3H444TC-W40	
Frame	: 444/5TC		Locked rotor time	: 39s (cold) 22s (hot)	
Output	: 150 HP (110 kW)		Temperature rise	: 80 K	
Poles	: 4		Duty cycle	: Cont.(S1)	
Frequency	: 60 Hz		Ambient temperature	: -20°C to +40°C	
Rated voltage	: 575 V		Altitude	: 1000 m.a.s.l.	
Rated current	: 136 A		Protection degree	: IP23	
L. R. Amperes	: 884 A		Cooling method	: IC01 - ODP	
LRC	: 6.5x(Code G)		Mounting	: F-1	
No load current	: 46.4 A		Rotation ¹	: Both (CW and CCW)	
Rated speed	: 1784 rpm		Noise level ²	: 78.0 dB(A)	
Slip	: 0.89 %		Starting method	: Direct On Line	
Rated torque	: 436 ft.lb		Approx. weight ³	: 1432 lb	
Locked rotor torque	: 200 %				
Breakdown torque	: 240 %				
Insulation class	: F				
Service factor	: 1.25				
Moment of inertia (J)	: 42.1 sq.ft.lb				
Design	: B				
Output	25%	50%	75%	100%	
Efficiency (%)	95.3	95.4	95.8	95.8	
Power Factor	0.49	0.74	0.82	0.85	
	Foundation loads				
	Max. traction : 2108 lb				
	Max. compression : 3541 lb				
		<u>Drive end</u>		<u>Non drive end</u>	
Bearing type	:	6319 C3	:	6314 C3	
Sealing	:	Without Bearing Seal	:	Without Bearing Seal	
Lubrication interval	:	20000 h	:	20000 h	
Lubricant amount	:	45 g	:	27 g	
Lubricant type	:	Mobil Polyrex EM			
Notes downloaded from http://dealerselectric.com					
This revision replaces and cancel the previous one, which must be eliminated. (1) Looking the motor from the shaft end. (2) Measured at 1m and with tolerance of +3dB(A). (3) Approximate weight subject to changes after manufacturing process. (4) At 100% of full load.			These are average values based on tests with sinusoidal power supply, subject to the tolerances stipulated in NEMA MG-1.		
Rev.	Changes Summary		Performed	Checked	Date
Performed by					
Checked by				Page	Revision
Date	16/04/2019			1 / 2	

LOAD PERFORMANCE CURVE



Three Phase Induction Motor - Squirrel Cage

Customer : Dealers Industrial Equipment 800-469-3110
 Customer reference : 15018OT3H444TC-W40

Product line : W40 NEMA Premium Efficiency Three-Phase Product code : 14272542
 Catalog # : 15018OT3H444TC-W40

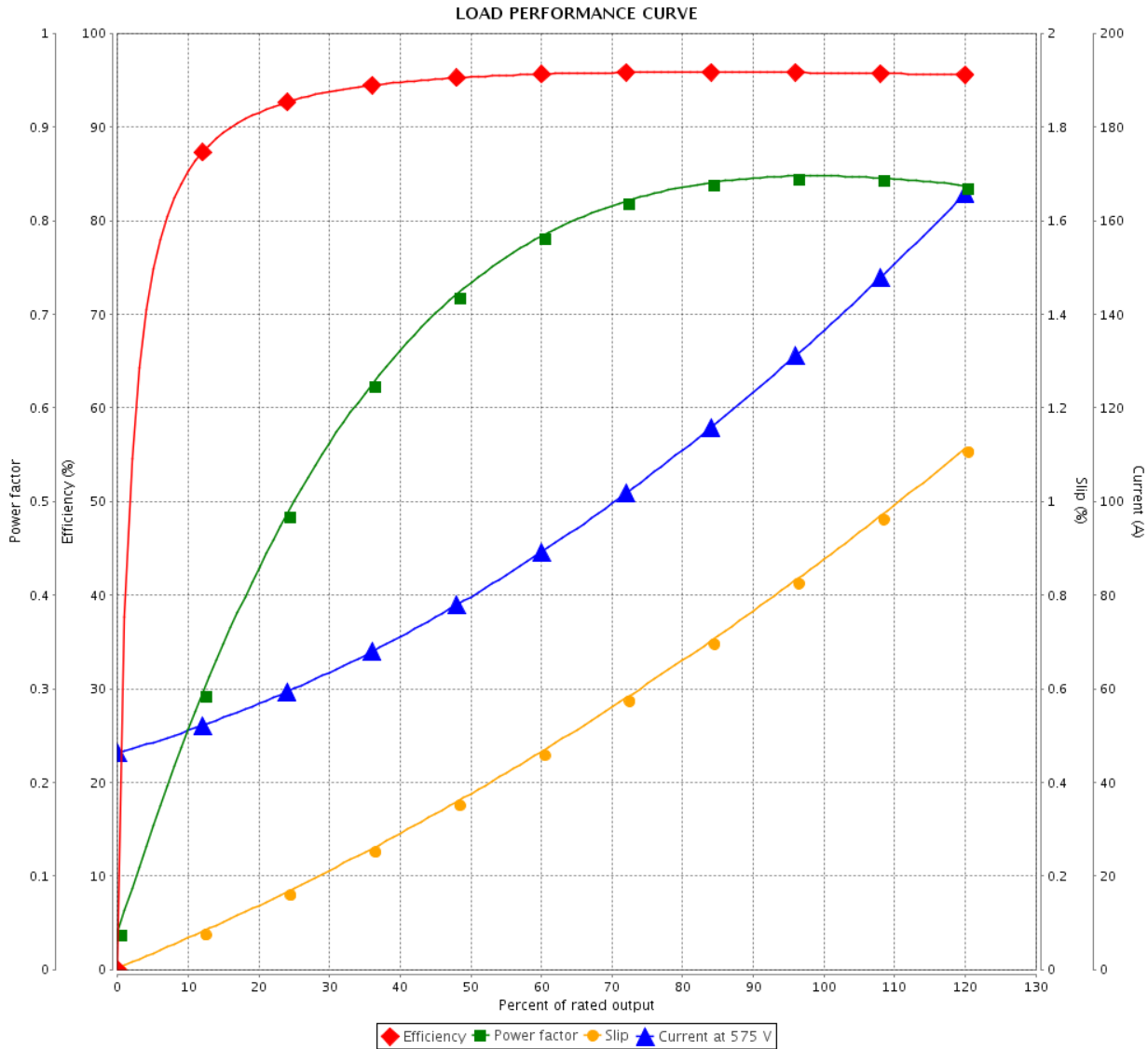

Performance : 575 V 60 Hz 4P

Rated current : 136 A	Moment of inertia (J) : 42.1 sq.ft.lb
LRC : 6.5	Duty cycle : Cont.(S1)
Rated torque : 436 ft.lb	Insulation class : F
Locked rotor torque : 200 %	Service factor : 1.25
Breakdown torque : 240 %	Temperature rise : 80 K
Rated speed : 1784 rpm	Design : B

Rev.	Changes Summary	Performed	Checked	Date
Performed by			Page	Revision
Checked by			2 / 2	
Date	16/04/2019			

Dimensões em polegada
Dimensions in inches

THIS IS AN UPDATED REVISION, THE
PREVIOUS ONE MUST BE DISREGARDED.

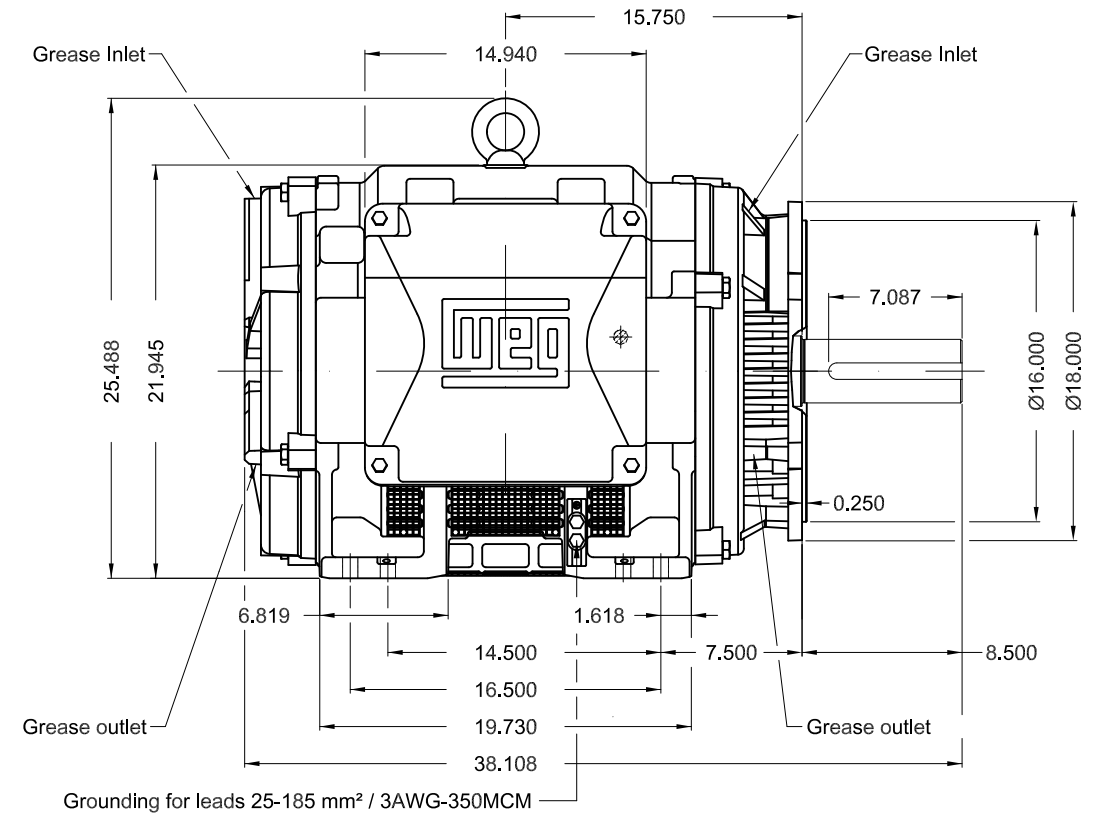
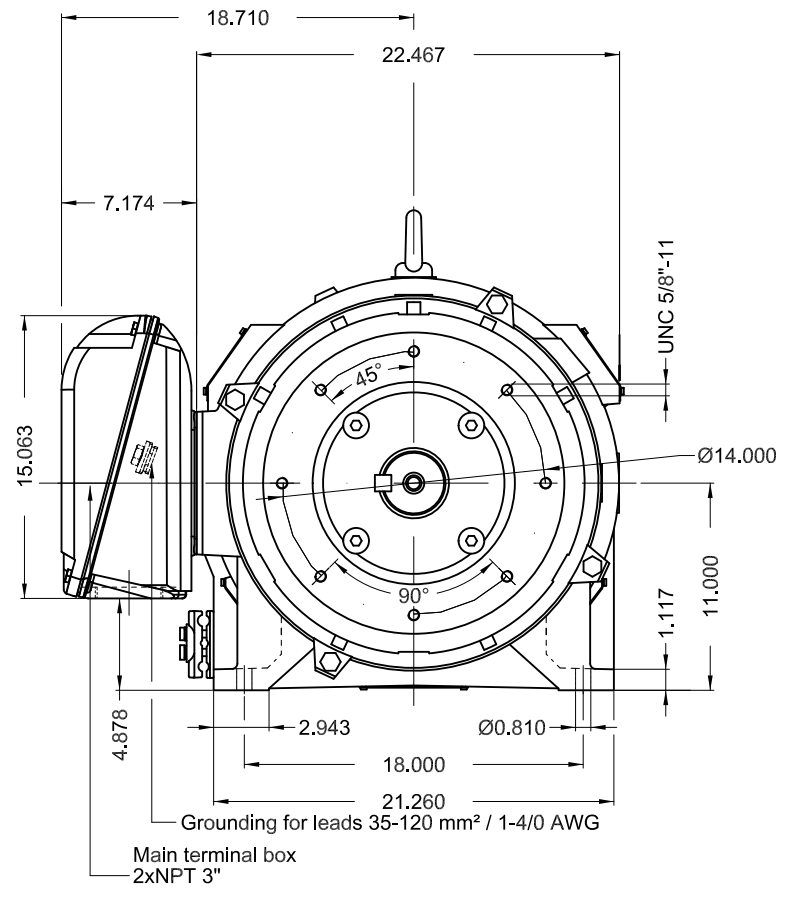

C3 NDE bearing						
Color RAL 5009						
Painting plan 203A						
Mounting B34R(D)						
					SCALE	1:10
ECM	LOC	SUMMARY OF MODIFICATIONS		EXECUTED	CHECKED	RELEASED
EXECUTED	USERADMIN	THREE PHASE W40 MOTOR NEMA PREMIUM EFF				
CHECKED		FRAME 444/5TC IP23 ODP				
RELEASED		WEG code: 14272542				
REL DT	16.04.2019	WMO	Jaragua do Sul	Product Engineering	SHEET	1 / 1

150 HP 04 Poles 60Hz

A



ZME A3