

DATA SHEET



Three Phase Induction Motor - Squirrel Cage

Customer : Dealers Industrial Equipment 800-469-3110						
Customer reference : 15018OT3G444T-W40						
Product line : W40 NEMA Premium Efficiency Three-Phase		Product code : 14272538				
		Catalog # : 15018OT3G444T-W40				
Frame : 444/5T Output : 150 HP (110 kW) Poles : 4 Frequency : 60 Hz Rated voltage : 460 V Rated current : 170 A L. R. Amperes : 1105 A LRC : 6.5x(Code G) No load current : 58.0 A Rated speed : 1784 rpm Slip : 0.89 % Rated torque : 436 ft.lb Locked rotor torque : 200 % Breakdown torque : 240 % Insulation class : F Service factor : 1.25 Moment of inertia (J) : 42.1 sq.ft.lb Design : B		Locked rotor time : 39s (cold) 22s (hot) Temperature rise : 80 K Duty cycle : Cont.(S1) Ambient temperature : -20°C to +40°C Altitude : 1000 m.a.s.l. Protection degree : IP23 Cooling method : IC01 - ODP Mounting : F-1 Rotation ¹ : Both (CW and CCW) Noise level ² : 78.0 dB(A) Starting method : Direct On Line Approx. weight ³ : 1382 lb				
Output	25%	50%	75%	100%		
Efficiency (%)	95.3	95.4	95.8	95.8		
Power Factor	0.49	0.74	0.82	0.85		
Foundation loads						
Max. traction : 2726 lb						
Max. compression : 4108 lb						
		<u>Drive end</u>		<u>Non drive end</u>		
Bearing type	:	6319 C3		6314 C3		
Sealing	:	Without Bearing Seal		Without Bearing Seal		
Lubrication interval	:	20000 h		20000 h		
Lubricant amount	:	45 g		27 g		
Lubricant type	:	Mobil Polyrex EM				
Notes downloaded from http://dealerselectric.com						
This revision replaces and cancel the previous one, which must be eliminated. (1) Looking the motor from the shaft end. (2) Measured at 1m and with tolerance of +3dB(A). (3) Approximate weight subject to changes after manufacturing process. (4) At 100% of full load.			These are average values based on tests with sinusoidal power supply, subject to the tolerances stipulated in NEMA MG-1.			
Rev.	Changes Summary			Performed	Checked	Date
Performed by						
Checked by					Page	Revision
Date	16/04/2019				1 / 2	

LOAD PERFORMANCE CURVE



Three Phase Induction Motor - Squirrel Cage

Customer : Dealers Industrial Equipment 800-469-3110
 Customer reference : 15018OT3G444T-W40

Product line : W40 NEMA Premium Efficiency Three-Phase Product code : 14272538
 Catalog # : 15018OT3G444T-W40

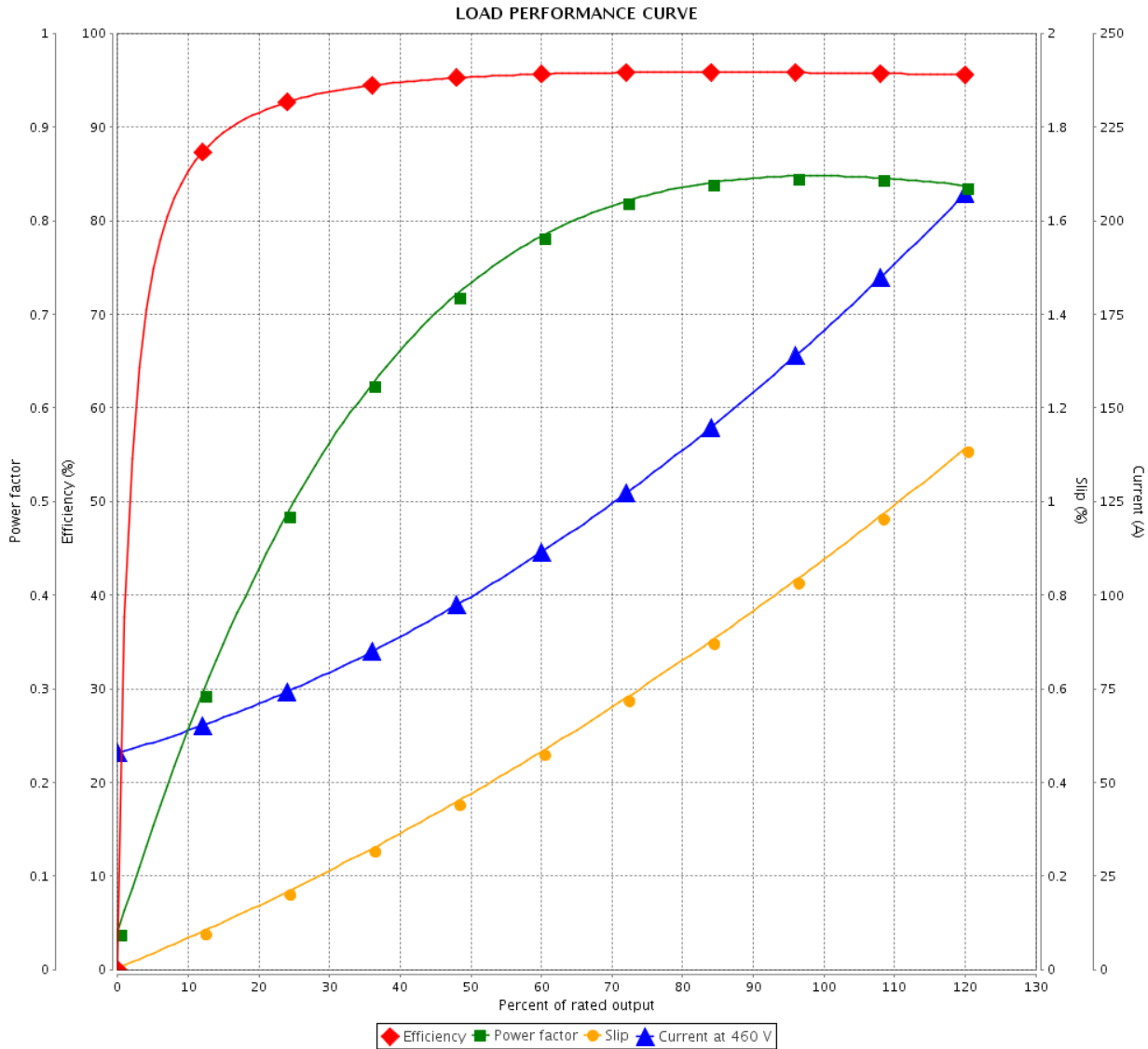

Performance : 460 V 60 Hz 4P

Rated current : 170 A	Moment of inertia (J) : 42.1 sq.ft.lb
LRC : 6.5	Duty cycle : Cont.(S1)
Rated torque : 436 ft.lb	Insulation class : F
Locked rotor torque : 200 %	Service factor : 1.25
Breakdown torque : 240 %	Temperature rise : 80 K
Rated speed : 1784 rpm	Design : B

Rev.	Changes Summary	Performed	Checked	Date
Performed by			Page 2 / 2	Revision
Checked by				
Date	16/04/2019			

Dimensões em polegada
Dimensions in inches

THIS IS AN UPDATED REVISION, THE
PREVIOUS ONE MUST BE DISREGARDED.

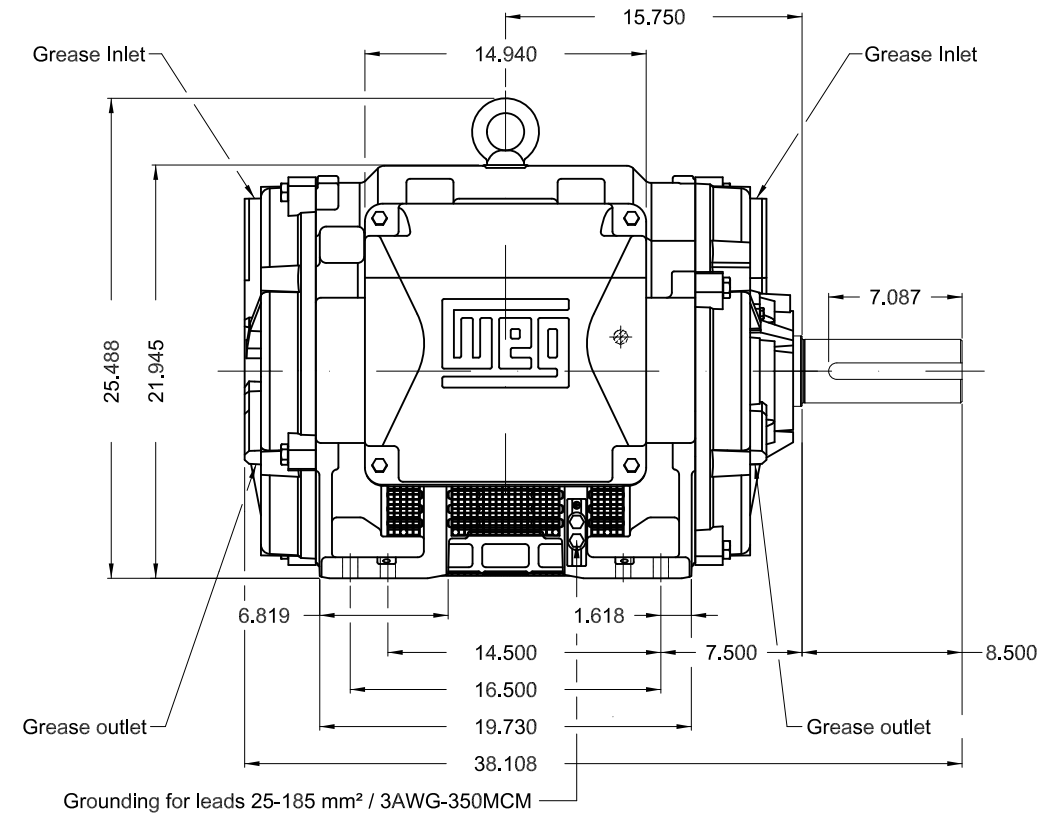
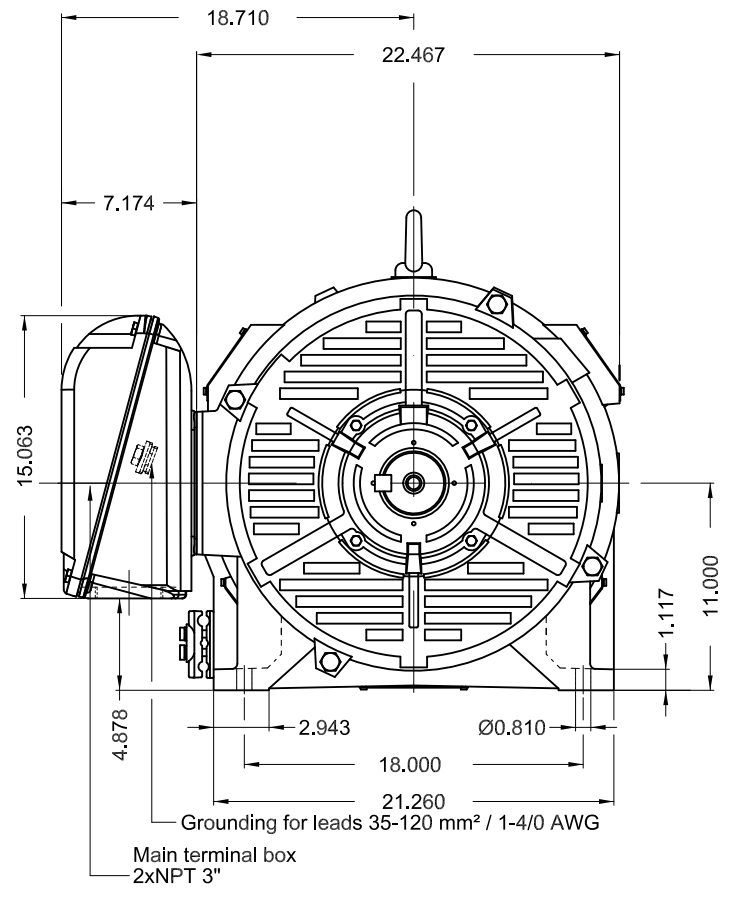

C3 NDE bearing						
Color RAL 5009						
Painting plan 203A						
Mounting B3R(D)						
					SCALE	1:10
ECM	LOC	SUMMARY OF MODIFICATIONS		EXECUTED	CHECKED	RELEASED
EXECUTED	USERADMIN	THREE PHASE W40 MOTOR NEMA PREMIUM EFF				
CHECKED		FRAME 444/5T IP23 ODP				
RELEASED		WEG code: 14272538				
REL DT	16.04.2019	WMO	Jaragua do Sul	Product Engineering	SHEET	1 / 1

150 HP 04 Poles 60Hz

A

