

DATA SHEET



Three Phase Induction Motor - Squirrel Cage

Customer	: Dealers Industrial Equipment 800-469-3110				
Customer reference	: 10018OT3H404T-W40				
Product line	: W40 NEMA Premium Efficiency Three-Phase	Product code :	14272478		
		Catalog # :	10018OT3H404T-W40		
Frame	: 404/5T	Locked rotor time	: 21s (cold) 12s (hot)		
Output	: 100 HP (75 kW)	Temperature rise	: 80 K		
Poles	: 4	Duty cycle	: Cont.(S1)		
Frequency	: 60 Hz	Ambient temperature	: -20°C to +40°C		
Rated voltage	: 575 V	Altitude	: 1000 m.a.s.l.		
Rated current	: 92.0 A	Protection degree	: IP23		
L. R. Amperes	: 626 A	Cooling method	: IC01 - ODP		
LRC	: 6.8x(Code G)	Mounting	: F-1		
No load current	: 31.8 A	Rotation ¹	: Both (CW and CCW)		
Rated speed	: 1780 rpm	Noise level ²	: 69.0 dB(A)		
Slip	: 1.11 %	Starting method	: Direct On Line		
Rated torque	: 291 ft.lb	Approx. weight ³	: 950 lb		
Locked rotor torque	: 200 %				
Breakdown torque	: 250 %				
Insulation class	: F				
Service factor	: 1.25				
Moment of inertia (J)	: 21.9 sq.ft.lb				
Design	: B				
Output	50%	75%	100%	Foundation loads	
Efficiency (%)	95.0	95.4	95.4	Max. traction : 1737 lb	
Power Factor	0.75	0.83	0.86	Max. compression : 2687 lb	
		<u>Drive end</u>	<u>Non drive end</u>		
Bearing type	:	6316 C3	6212 Z C3		
Sealing	:	Without Bearing Seal	Without Bearing Seal		
Lubrication interval	:	20000 h	20000 h		
Lubricant amount	:	34 g	13 g		
Lubricant type	:	Mobil Polyrex EM			
Notes downloaded from http://dealerselectric.com					
This revision replaces and cancel the previous one, which must be eliminated. (1) Looking the motor from the shaft end. (2) Measured at 1m and with tolerance of +3dB(A). (3) Approximate weight subject to changes after manufacturing process. (4) At 100% of full load.			These are average values based on tests with sinusoidal power supply, subject to the tolerances stipulated in NEMA MG-1.		
Rev.	Changes Summary		Performed	Checked	Date
Performed by					
Checked by				Page	Revision
Date	15/04/2019			1 / 2	

LOAD PERFORMANCE CURVE



Three Phase Induction Motor - Squirrel Cage

Customer : Dealers Industrial Equipment 800-469-3110
 Customer reference : 10018OT3H404T-W40

Product line : W40 NEMA Premium Efficiency Three-Phase Product code : 14272478
 Catalog # : 10018OT3H404T-W40

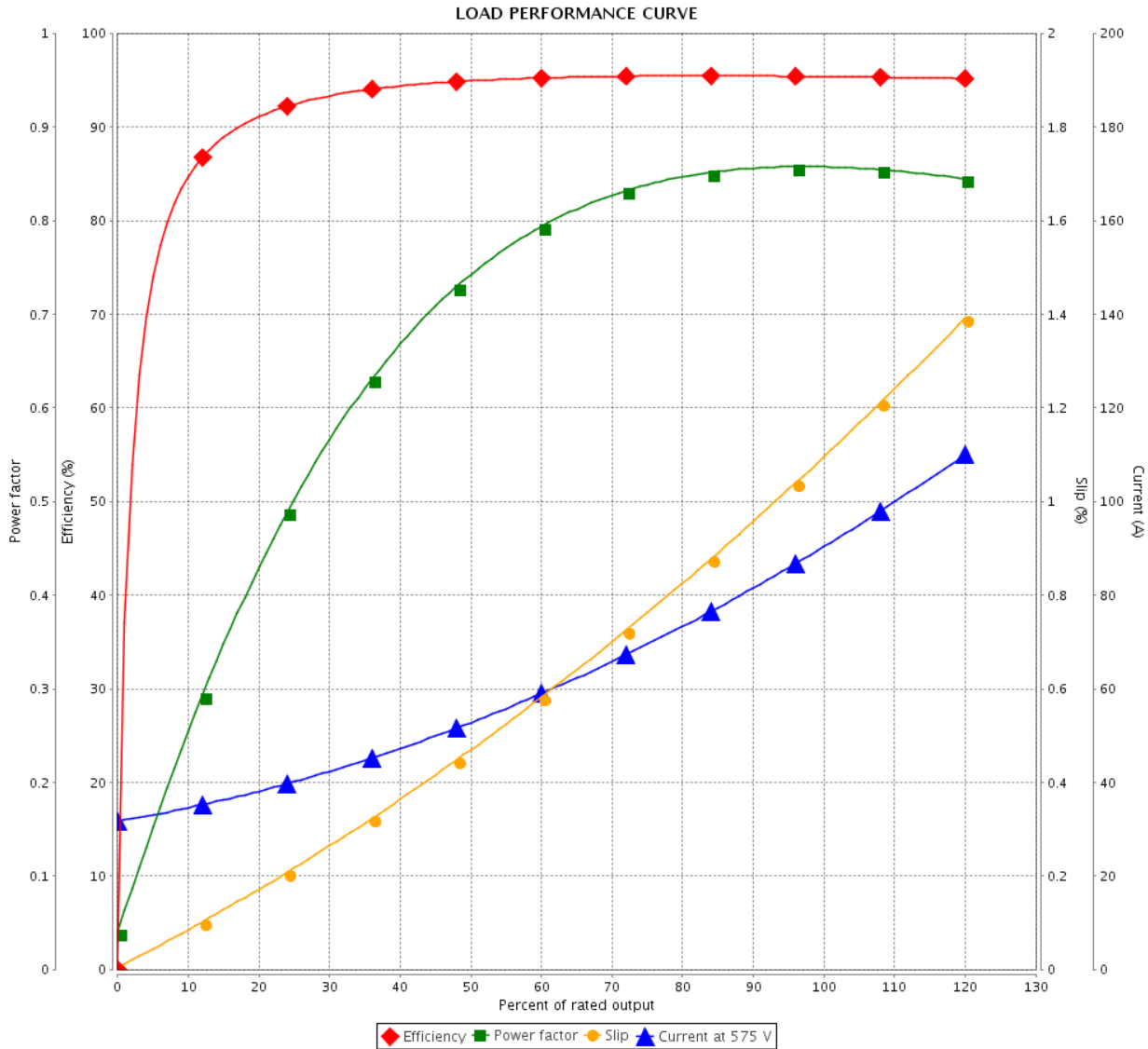

Performance : 575 V 60 Hz 4P

Rated current : 92.0 A	Moment of inertia (J) : 21.9 sq.ft.lb
LRC : 6.8	Duty cycle : Cont.(S1)
Rated torque : 291 ft.lb	Insulation class : F
Locked rotor torque : 200 %	Service factor : 1.25
Breakdown torque : 250 %	Temperature rise : 80 K
Rated speed : 1780 rpm	Design : B

Rev.	Changes Summary	Performed	Checked	Date
Performed by			Page	Revision
Checked by				
Date				

Dimensões em polegada
Dimensions in inches

THIS IS AN UPDATED REVISION, THE
PREVIOUS ONE MUST BE DISREGARDED.

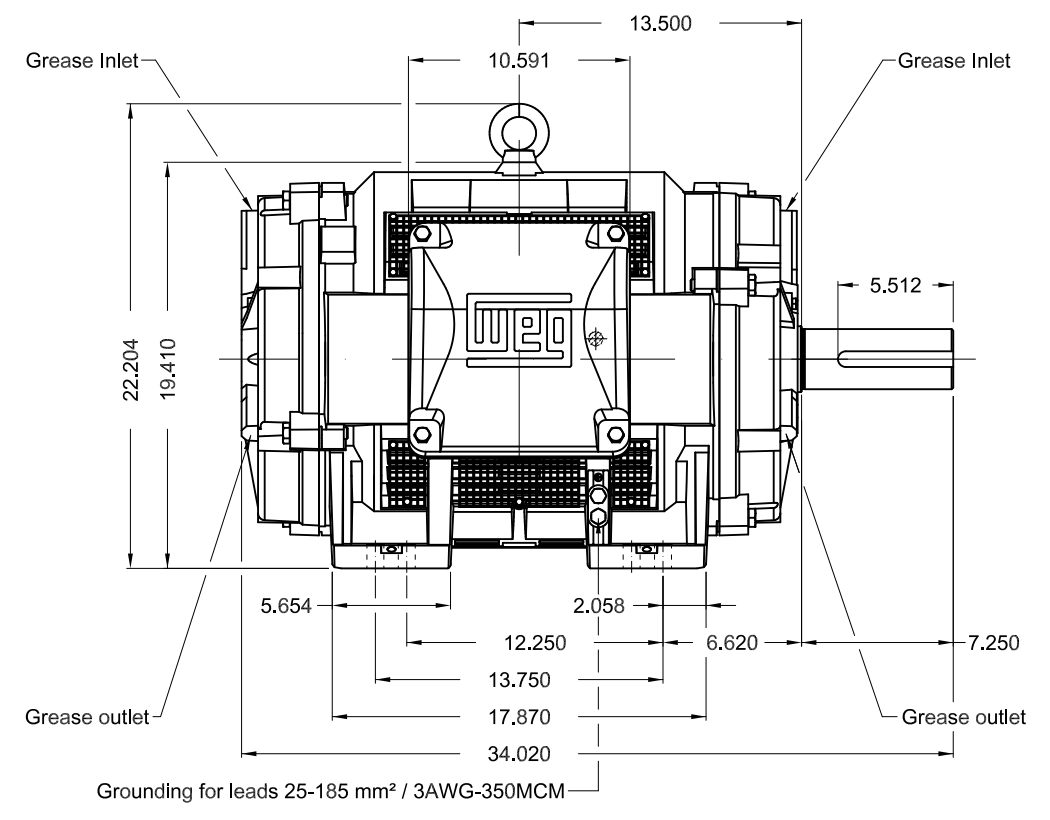
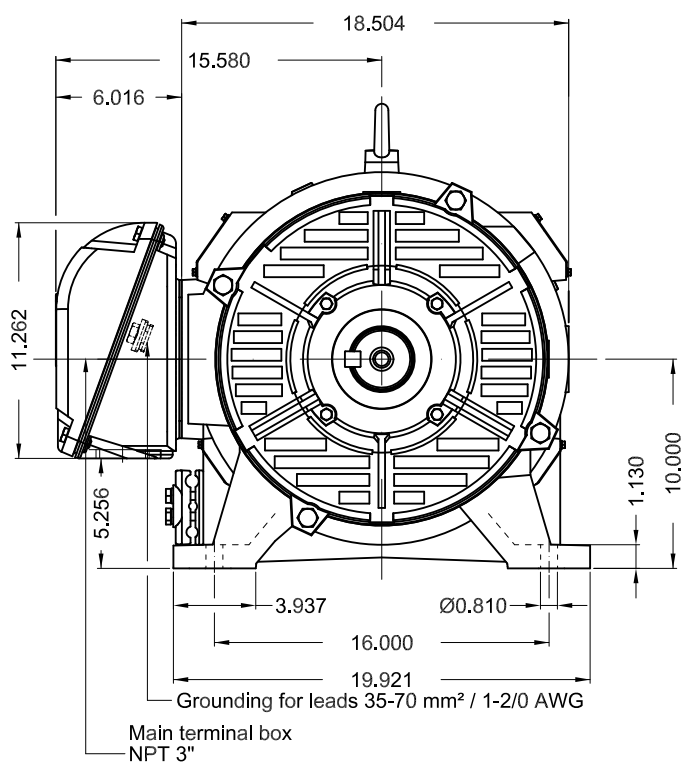

Color RAL 5009						
Painting plan 203A						
Mounting B3R(D)						
					SCALE	1:9
ECM	LOC	SUMMARY OF MODIFICATIONS			EXECUTED	CHECKED
EXECUTED	USERADMIN	THREE PHASE W40 MOTOR NEMA PREMIUM EFF				
CHECKED		FRAME 404/5T IP23 ODP				
RELEASED		WEG code: 14272478				
REL DT	15.04.2019	WMO	Jaragua do Sul	Product Engineering	SHEET	1 / 1

100 HP 04 Poles 60Hz

A

